

The efficiency improvement of the shoe polishing machine for SMEs footwear industry

*I Made Arsana*¹, *Nur Kholis*^{2*}, *Yuli Sutoto Nugroho*³, *Theodorus Wiyanto Wibowo*¹, and *Catur Surya Saputra*^{1,4}

¹Departement Mechanical Engineering, State University of Surabaya, Surabaya, Indonesia.

²Department Electrical Engineering, State University of Surabaya, Surabaya, Indonesia.

³School of Electronic Engineering and Computer Science, Queen Mary University of London, London.

⁴Department Science Education, State University of Surabaya, Surabaya, Indonesia

Abstract. The Shoe Polishing Machine has become an essential device in household and commercial environments to restore shine and extend the life of shoes while saving time and effort. The machine is equipped with a soft brush and polish dispenser, providing an efficient and convenient way to revitalize shoes without the need for manual polishing. Various types of shoe materials such as leather, synthetics, and suede can be treated with this machine, which comes with adjustable shine and polish intensity settings. The advantages of the Shoe Polishing Machine include saving time and effort, suitable for use in hotels, airports, and shoe shops. It also improves hygiene by reducing the spread of polish residue and germs common with manual polishing. The safety of Shoe Polishing Machine users is also a priority with the built-in safety mechanism. Maintenance is easy, making the machine reliable in the long run. Overall, the Shoe Polishing Machine is essential for maintaining the appearance and quality of shoes. With its automatic operation, versatility, and convenience, it is a valuable asset in personal and commercial shoe care. This machine can be used as an efficient and effective solution to achieve flawlessly shiny shoes.

1 Introduction

The younger generation now has a tendency to follow the latest trends or up to date, they have a strong appeal, dare to express themselves, have confidence in their appearance, are afraid of being out of fashion, and have a relaxed yet fashionable style [1]. Fashion is a reflection of the style of dress, accessories, hairstyle, and other elements that can enhance one's appearance [2]. Fashion is supported by several things that can increase the slickness of the clothes worn, one of which is shoes. Shoes are quite important when it comes to dressing style [3]. Various shoe models include flat shoes, boots, oxfords, heels, sneakers, and others that have different wearing functions, depending on fashion needs and fashion styles [4].

* Corresponding author: nurkholis@unesa.ac.id

In line with the significant use of shoes based on data, Indonesia is among the top four footwear-producing countries in the world. Indonesia is behind China, India, and Vietnam in shoe production [5]. The number of footwear industries in Indonesia is recorded at 18,687 business units, including 18,091 small-scale business units, 441 medium-scale business units, and 155 large-scale business units. Of the tens of thousands of business units, labor absorption has reached 795,000 people⁵. Starting from the data, the need for the use of shoes is very high. The amount of use of shoes in daily activities allows a person to have more than one shoe [6]. So, the maintenance of two to three shoes also requires a lot of time and energy [7]. If the shoes look dirty when worn or not shiny, it will reduce the attractiveness and confidence in appearance. So, shoe polishing is needed to keep the shoes looking clean and shiny.

Shoe polishing of shoe soles is intended to sparkle and avoid shoe dust. Manual shoe polishing requires a long time and a lot of energy [8]. Self-polishing if not using the correct technique can damage the shoe and shorten the life of the shoe. Along with the rapid advancement of technology and the development of increasingly modern times, humans are faced with pressure to continue to innovate. In the era of globalization, time is considered precious and it is important to manage activities well [9].

Micro, small and medium enterprises (SMEs) generally have shoe polishing machines using open electric motors with the help of polishing burrs [10]. Machines in existing MSMEs on average come from their own assemblies and are not equipped with adequate security and also pay less attention in terms of health, where the coarse grinding wheels used will produce waste dust that has an impact on air pollution and breathing (health). In addition, the quality of conventional polishers has the potential to produce poor products due to unstable hand conditions in the polishing process. This machine can be crucial because it can save time and effort. Shoe polishing machines can also restore the shine of shoes and can extend the life of shoes. shoe polishing machines that can save users time and effort, and can improve shoe hygiene. A simple shoe polishing tool can be seen in Figure 1.



Fig. 1. Simple polishing tool

Based on the observation of the problem, it is necessary to apply appropriate technology to help facilitate shoe polishing. One of the appropriate technologies needed is an automatic shoe polishing machine equipped with a soft brush and polish dispenser,

which can provide efficiency and comfort in revitalizing shoes [11]. The polishing machine will also be designed with adjustable shine and polish intensity settings. The safety of the user is also a priority so there is a built-in safety mechanism. [12]. Prakoso et al. [13] made a shoe polishing machine to help MSMEs, but the machine is not yet equipped with a Raspberry PI for calculations. This developed polishing machine is equipped with Raspberry PI for the calculation process of shoe productivity accurately, easily, and with many other advantages. The next advantage is easy maintenance so that it can be relied on in the long run. This shoe polishing machine can reduce polish residue and germs in manual polishing. In addition, this machine is equipped with a blower that functions to suck dust from the shoe sole polishing process. The filter on this machine will filter dust so that the air that comes out becomes clean, reduces pollution, and is environmentally friendly. The machine is also equipped with polishing eyes that are used to polish shoe soles that are not neat after gluing. With automatic machine operation and easy maintenance, this machine can be relied on personally or commercially.

2 Methods

This research activity has been carried out for five months in Sidoarjo Regency, East Java Province. The implementation of this research activity was carried out through several stages, namely:

2.1 Field observation

Observation activities are one of the vital stages in order to identify problems that actually occur in the field. At this stage, researchers found problems in the form of low quality and quantity of shoe production.

2.2 Design

Designing activities begin with making a design. The design-making process uses the help of SolidWorks software. The next stage is manufacturing by making the main components first and then continuing with other supporting components.

2.3 Polishing machine application

Procurement and application of a press machine equipped with a Raspberry Pi, suction blower, and Hepa filter equipped with purified water. The polishing machine will provide convenience to users to smooth and polish the perimeter of the shoe.

3 Result and discussion

The research was conducted from May to September 2023. Prioritized problems exist in production that must be resolved immediately. The problem is obtained by collecting data and various information on an existing problem. Based on the problems in the field directly, there are problems that need to be solved. The problem that needs to be solved

is the process of selep shoes using an open electric motor with the help of coarse grinding eyes, the results of the selep process of used selep garbage flying and scattering have a bad impact on health. In addition, the quality of the process is not good due to unstable hand conditions and lack of ergonomics, which cause operators to tend to get tired quickly.

The solution to solve the existing problems will be to design a semi-automatic shoe polishing and buffing machine integrated with Raspberry PI. This machine is designed to have two roles, which can polish shoes and shine shoes, so it is expected to be used for polishing and buffing it is equipped with a suction blower to suck up flying dust as well as to improve the quality of shoes. The design of the machine begins with making a design first. The machine design is made with the help of the SolidWorks application. The results of the polishing machine design can be seen in Figure 2.

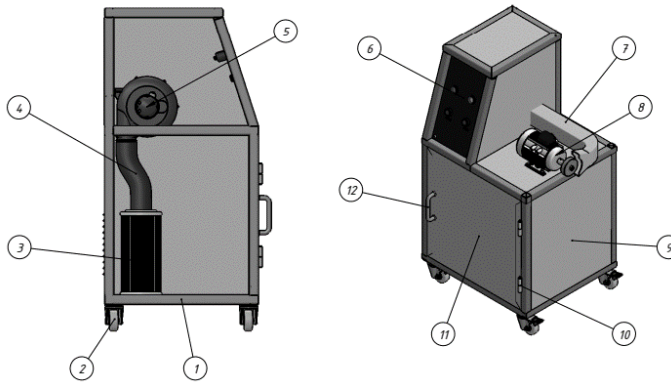

Fig. 2. Detail machine

Table 1. Image description

No	Description	Specification
1	Frame Unit	Stainless steel
2	Wheels	Plastic
3	Hepa Filter	30cm x 20cm
4	Hose	2"
5	Blower	350 watt
6	Control Panel	1. Emergency 2. ON 3. OFF 4. Counter 5. LCD
7	Suction Line	2"
8	Electric Motor	0.5 HP
9	Cover Unit	Stainless stell
10	Hinge	
11	Door Unit	
12	Door Handle	

Based on Figure 2, it can be seen that the semi-automatic shoe polishing and buffing machine integrated with Raspberry Pi consists of many main components. The first component starts with the vacuum cleaner blower, hipa filter, and Raspberry Pi. Semi-automatic shoe polishing and buffing machine integrated Raspberry Pi is designed to smooth the circumference of shoes driven by a high-speed electric motor equipped with a vacuum blower, so that it is able to polish the circumference and skin of very smooth shoes, very fast time and healthy working environment. [14]. A suction blower serves to suck dust so that it does not fly away [15]. The engine is also equipped with a hepa filter that functions to filter the air so that the air released from the engine is no longer dirty [16]. The rear view of the machine with the suction blower visible can be seen in Figure 3.



Fig. 3. Rear view of engine

The semi-automatic shoe polishing and buffing machine is equipped with a Raspberry Pi. Raspberry Pi is one of the Internet of Things (IoT) components that can be applied to remote control with internet networks that can be applied to electronic equipment. Raspberry Pi functions to calculate the number of shoes that have been polished using a polishing machine [17]. An example of the front view of the machine can be seen in Figure 3 and the specifications of this tool can be seen in Table 2.

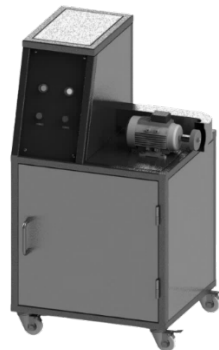

Fig. 4. Machine front view

Table 2. Machine specifications

No	Description	Specifications
1	Dimensions	p: 65cm x l: 52cm x t: 110cm
2	Electric motor	0.5 hp
3	Material	Stainless steel
4	Round	1500 rpm
5	Power	750 Watt

Procedures or stages to operate the semi-automatic shoe polishing and buffing machine integrated Raspberry PI, are as follows: first plug the machine power cable into the power source. After the cable is connected press the on button to turn on the machine. Polish shoes as needed. When each shoe is finished polishing, press the "Count" button to enter the number of shoes that have been obtained to the server. Then press the off button after the machine is not in use. This machine has been tested to determine the speed in polishing the circumference and very fine shoe leather. The test results of this tool can be seen in Figure 5.

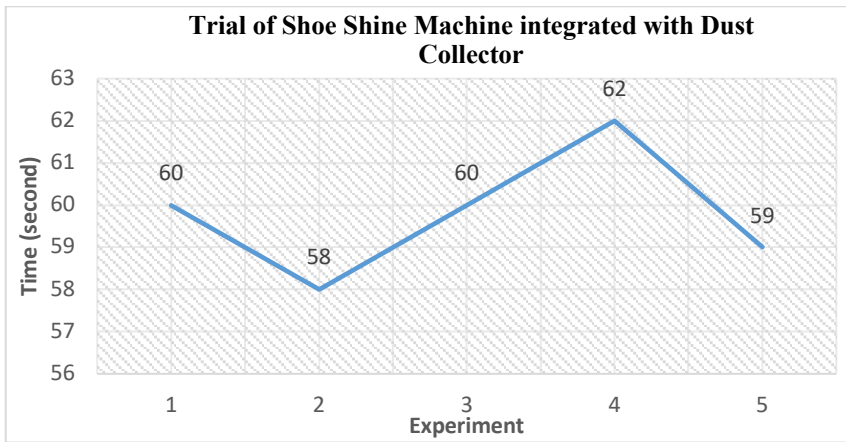

Fig. 5. Test results of shoe shine machine integrated with dust collector

The figure explains the results of machine trials conducted to polish the circumference and skin of very fine shoes with each trial tested on six pairs of shoes and the time required. The average time required to polish the circumference and skin of a pair of very fine shoes is 60 seconds or each pair of shoes only takes 10 seconds. The results of this trial are in line with research conducted by Jiao et al. [18] that the polishing machine has a simple structure and high processing efficiency, and can effectively polish such flat or round surfaces when combined with a dust collector. This machine also prioritizes safety in work, besides that it is also relatively easy to maintain. This polishing machine can be used as an efficient and effective solution to get shiny, flawless shoes.

4 Conclusion

The advantages of the Shoe Polish Machine include saving time and effort, suitable for use in hotels, airports, and shoe shops. It also improves hygiene by reducing the spread of polish residue and germs that are common with manual polishing. The safety of Shoe Polish Machine users is also a priority with the built-in safety mechanism. Maintenance is easy, making this machine reliable in the long run. Overall, a Shoe Polishing Machine is essential for maintaining the appearance and quality of shoes. This machine can improve quality and production in MSMEs. It can also be used as an efficient and effective solution to get shiny, flawless shoes.

References

1. J. A. Friedman, R. Zeckhauser, *Intelligence and National Security* **31** (2016)
2. L. Maghfiroh, S. S. Iriani, *Jurnal Ilmu Manajemen* **9** (2021)
3. A. M. Rahmawati, et al, *Co. Management, and Industry (JEMI)* **3** (2020)
4. L. K. Yew, J. D. Tan, *South East Asia Res* **30** (2022)
5. K. P. R. I. Kemenperin, *The Fourth Largest Footwear Manufacturer in the World (Ministry of Industry, Indonesia, 2019)*
6. R. Aznar-Gimeno, et al. *Entropy* **23**, 777 (2021)
7. S. Asano, et al., *Sens Actuators A Phys.* **309** (2020)
8. E. Chanty, *JISO: Journal of Industrial and Systems Optimization* **2**, 2 (2019)
9. P. Ramesh, M. Anish, J. B. Sundar, A. D Raj, *International Research Journal of Multidisciplinary Technovation* **1** (2019)
10. M. Niam, *Machine control and electrical systems (PT. Nasya Expanding Management, Indonesia, 2021)*
11. M. Alfian, H. L. Wijayanto, K. Kadriadi, M. Jafar, *Jurnal Ilmiah Universitas Batanghari Jambi* **23**, 1080 (2023)
12. J. Braband, H. Schäbe, *Safety and Reliability* **36** (2016)
13. A. F. Prakoso, D. Suwito, Yunus, *Jurnal Pemberdayaan Masyarakat Madani (JPMM)* **6** (2022)
14. D. R. Mandel, T. L. Hendriks, D. Irwin, *Intelligence and National Security* **37** (2022)
15. S. K. Sun, X. H. Jia, L. F. Xing, X. Y. Peng, *Engineering Applications of Computational Fluid Mechanics* **12** (2018)
16. D. A. Newcomer, P. LaPuma, R. Brandys, A. Northcross, *J Occup Environ Hyg.* **15** (2018)
17. K. Žáková, M. Rábek, *IFAC-PapersOnLine* **51** (2018)
18. C. Jiao, Y. Shu, Y. Chen, Z. Zhang, *Optik (Stuttg)* **224**, 165436 (2020)