

Investigation of the High-Voltage Converter for Powering Electrostatic Precipitators

*Lyubov Roginskaya*¹, *Zulfiya Yalalova*^{2,*}, *Anton Gorbunov*^{1,†}, *Ruslan Karimov*¹, *Vladimir Tereshkin*² and *Nikolai Senyushkin*¹

¹Ufa University of Science and Technology, Ufa, Russia

²Ufa transformer plant separate subdivision, Ufa, Russia

Abstract. The article is devoted to the study of the power supply for air purification systems using electrostatic precipitators (ESP). The features of operation of the in-put thyristor regulator for changing the output parameters of the power source are considered. The nominal electromagnetic and design parameters of the elements of the ESP power supply circuit are presented. Mathematical expressions describing electromagnetic processes in the ESP are given. A computer simulation of a system including a power supply with an ESP was performed, taking into account the real parameters of the device elements. The characteristics of out-put parameters of the power supply are obtained for various firing angles of the input regulator and various connected numbers of turns of the high-voltage trans-former.

1 Introduction

The scale of human production activity has led to noticeable negative consequences for the environment due to significant industrial emissions. Increasing requirements of environmental standards for the purity of industrial emissions necessitate the use of cleaning devices. One of the best methods of purifying gases and trapping particles in the air is the use of ESP [1], based on air ionization using a corona discharge in the electrode area.

In [2] mathematical and numerical modeling of physical processes in the ESP was performed. Graphs of the dependence of the ESP efficiency on its parameters were obtained. In [3, 4], a study and mathematical modeling of physical processes during the operation of the ESP was carried out, the scheme of which is shown in Fig. 1, a. This ESP consists of several rods inside the channel, which are discharge electrodes, while the channel walls are collecting electrodes (positively charged).

An article [5] is devoted to the study of the operation of an ESP with several sections with discharge electrodes with additional spikes in the form of stars (Fig. 1, b). These authors investigated the degree of influence of these additional elements on the inhomogeneity of the electric field.

* Corresponding author: freizer-anton@yandex.ru

† Corresponding author: yalalova_zi@mail.ru

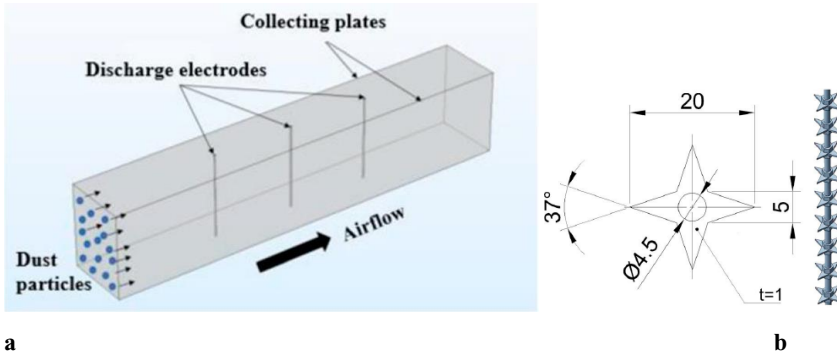

Fig. 1. ESP design: a – general form; b - discharge electrode shape.

Currently, several of the most widely used technical solutions in the field of power supply circuits for ESPs are known:

1. Power supplies in which high voltage is obtained using a mains frequency transformer and a diode rectifier (Fig. 2, a) [6]. Such devices are characterized by comparative simplicity and high efficiency.

2. High-frequency power supplies based on a high-frequency transistor inverter, step-up transformer and rectifier (Fig. 2, b) [7, 8, 9]. Disadvantages of this type: a number of proposed circuits are characterized by the presence of hard switching during the operation of a transistor inverter, which increases the level of switching losses and heating of the transistors; non-sinusoidal current consumption from a network.

3. Switching supplies. A noticeable advantage of ESP switching power supplies is the increased reliability of operation with the elimination of the harmful effects of back corona [10].

4. Other options for ESP power sources include: high-frequency sources using a high-voltage transformer with several secondary windings [11], which makes it possible to reduce leakage inductance. The last source considered is the variant with the use of isolation transformers, and semiconductor modules with DC-DC converters are used as converters to obtain high voltage [12]. These options are characterized by complexity of device circuits.

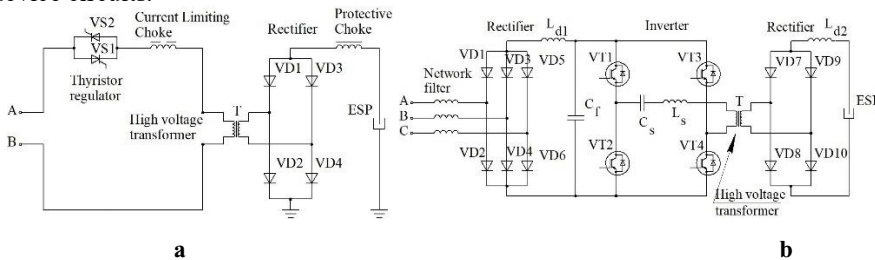

Fig. 2. Power Supply Diagrams: a – with mains frequency transformer; b – with inverter.

2 Formulation of the problem

ESP performance indicators significantly depend on the quality of their power sources, therefore, in the analysis, the relevant processes should be considered jointly, including taking into account the parameters of the source elements with a high-voltage transformer and the parameters of the control device (if any). In modern literary sources devoted to the

study of the operation of power sources of the ESP, insufficient attention is paid to taking into account the real parameters of the main electromagnetic elements of the converters, taking into account the influence of the features of controlling the operation of the supply voltage regulator of the high-voltage transformer-rectifier unit on electromagnetic processes in the ESP, as well as taking into account the real nonlinear current-voltage ESP characteristics. In the proposed article, the study of the influence of the parameters of the power supply elements on the performance of the ESP will be carried out on the basis of a power supply with a semiconductor (thyristor) regulator (TR), a high-voltage transformer and a rectifier, which are produced, for example, at JSC Elektroavod, Russia.

Another important problem in the operation of the ESP, the parameters of which are regulated using a TR is the "half-wave effect" [6], due to the fact that the operation of TR must be controlled taking into account a sufficient thyristor firing angle, the value of which should be at least the following value:

$$\alpha > \varphi_{load}, \tag{1}$$

where α is the firing angle, °; φ_{load} is the load angle relative to the TR, °.

Equation (1) can be written in the form that the following control pulse duration should be provided:

$$\omega t_{open} > (\varphi_{load} - \alpha), \tag{2}$$

where ω is the angular frequency, rad/s; t_{open} is the control pulse duration, s.

Therefore, during the operation of the TR, which are controlled by short-duration pulses, if conditions (1) and (2) are not met, one of the thyristors will not open, which will cause the transformer to work when exposed to a voltage of one polarity with a significant bias of the core. When studying the influence of the "half-wave effect", it is also necessary to take into account the influence of the parameters of the elements of their power sources.

Based on the foregoing, the proposed article is devoted to the creation of models of ESP power sources when working with TR, taking into account the real parameters of the elements and obtaining the characteristics of the ESP, depending on the regulation of the power supply parameters.

3 Study of ESP characteristics with APTD-1000 power unit

We will consider a converting transformer diode unit with a rated rectified current of 1000 mA, manufactured, for example, at JSC Elektroavod, Russia. «APTD-1000» is a unit consisting of a high-voltage transformer, a rectifier, an automatic control system «Sapphire» [13], an input TR, and two chokes: a protective and current-limiting one. A simplified schematic diagram of the «APTD-1000» power supply for an ESP is shown in Fig. 4.

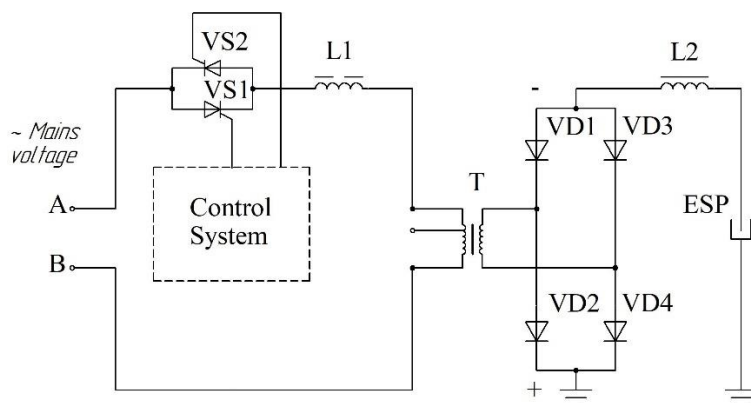

Fig. 3. Simplified schematic diagram of the «APTD-1000» unit.

Structurally, a high-voltage transformer consists of magnetic circuit with windings mounted on it. The secondary (valve) winding of the transformer is connected to a high-voltage rectifier assembled according to a single-phase bridge circuit (Fig. 3), and the primary winding is connected to the network through TR. The active parts of «APTD-1000» are oil cooled in the tank [13].

«Sapphire» regulator allows to regulate the parameters of the ESP by changing the firing angles of thyristors.

The manufactured «APTD-1000» uses a high-voltage transformer, protective and current-limiting chokes [6]. The nominal parameters of «APTD-1000» are presented in Table. 1 [14].

During the operation of the ESP, 2 characteristic modes are provided to ensure the values of the output voltage of the rectifier unit: 50 kV and 70 kV. In this case, the rated current of the primary winding at an output voltage of 50 or 70 kV corresponds to a certain control angle, which is provided by the Sapphire regulator. The minimum value of the firing angle is determined by the phase angle of the equivalent resistance of the installation with respect to the output of the TR.

To simulate the processes in the ESP with TR, an equivalent circuit was drawn up, shown in Fig. 4 [6].

Table 1. Nominal parameters of «APTD-1000».

Unit	Specification
Supply voltage at 50 Hz	380 V, 415 V
Supply voltage at 60 Hz	380 V, 400 V, 415 V, 440 V
Rated rectified voltage at maximum transformation ratio	70 kV DC
Rated rectified voltage at minimum transformation ratio	50 kV DC
Rated rectified current at maximum transformation ratio	700 mA DC
Rated rectified current at minimum transformation ratio	1000 mA DC
Efficiency	93 %

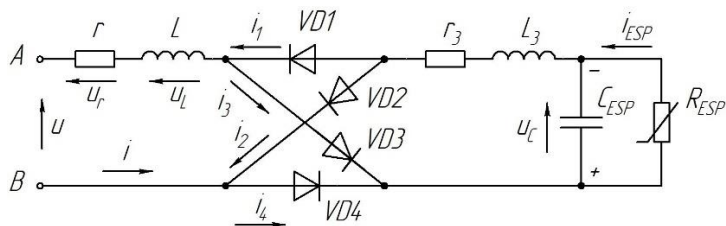

Fig. 4. ESP power supply equivalent circuit.

A simplified mathematical model of the ESP (scheme in Fig. 5) is a system of equations for the derivatives of currents and voltages on the elements of the ESP:

$$\begin{cases} \frac{di}{dt} = \frac{u - r \cdot i - 2 \cdot i_1 \cdot r - u_C}{L}; & \frac{du_C}{dt} = \frac{1}{C_{ESP}} \cdot \left(i_1 + i_2 - \frac{u_C}{R_{ESP}} \right); \\ \frac{di_1}{dt} = \frac{-\frac{du_C}{dt} - r_2 \cdot \frac{di}{dt}}{r_1 + r_2}; & \frac{di_2}{dt} = \frac{-r_1 \cdot \frac{di}{dt} - \frac{du_C}{dt}}{r_1 + r_2}, \end{cases} \quad (3)$$

where r_1 and r_2 are the nonlinear resistances of the diodes VD1 and VD2.

The designations in (3) correspond to Fig. 4. System (3) is written for the case when the elements L and r take into account the resistance of the windings of the transformer and the current-limiting choke, while the protective choke (parameters r_3 and L_3), no-load losses and no-load current of the transformer are neglected.

To solve the problems posed in the article, simulation was carried out in the Matlab Simulink software for ESP with TR, taking into account the parameters of the elements under consideration. For simulation, the current-voltage characteristic of the ESP discharge gap was approximated as an exponential function:

$$i_{ESP} = 0.0007 \cdot e^{0.00009 \cdot U_C}. \quad (4)$$

According to the results of the analysis of literary sources, it was found that the value of the capacitance of the interelectrode space of the ESP varies depending on its design and dimensions and in many cases is 0.02-0.3 μF . In our model, the value $C_{ESP} = 0.3 \mu\text{F}$ was taken into account. Fig.5 shows the oscillograms of the currents at the output of the TR at firing angles of 45° and 90°. In the first case, the effective value of the current is 366 A, in the second - 241 A. Fig. 6 shows oscillograms of the ESP supply voltage at the same firing angles, the average values of which are 64.7 and 47.4 kV, respectively.

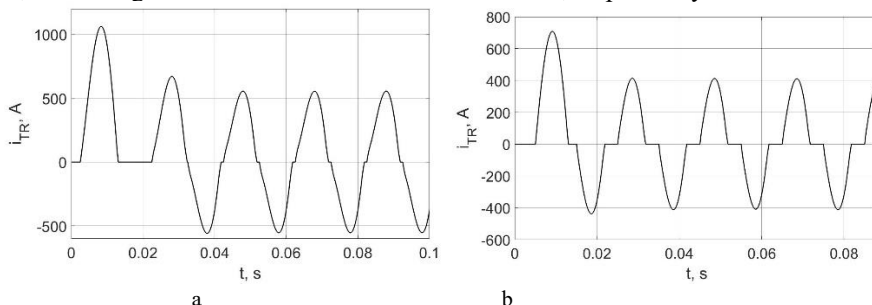

Fig. 5. Current oscillograms at the TR output at firing angles: a – 45°; b – 90°.

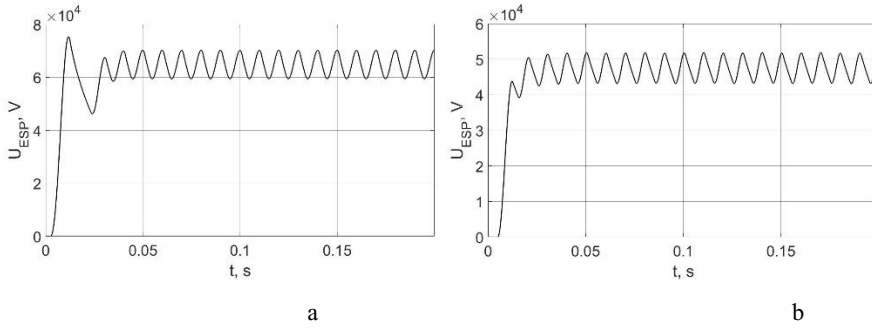

Fig. 6. Voltage at the ESP input at firing angles: a – 45°; b – 90°.

In this case, the number of turns of the primary winding of the transformer was taken $w_1 = 100\%$. As can be seen, the values of the output voltage of the converter turned out to be close to the initial data, which confirms the correctness of the calculations. Let us consider the features of the ESP operation at an angle of 40° (Fig. 7). As can be seen, at a firing angle of 40°, an emergency mode occurs in the ESP power source in the form of a “half-wave effect”, during which the magnetic circuit is biased by the DC component of the flux with a sharp increase in the magnetizing current by tens of times. In this mode, the «Sapphire» regulator should automatically change the firing angle. According to the modeling performed, the firing angle value of 45° is close to the minimum allowable firing angle at $w_1 = 100\%$.

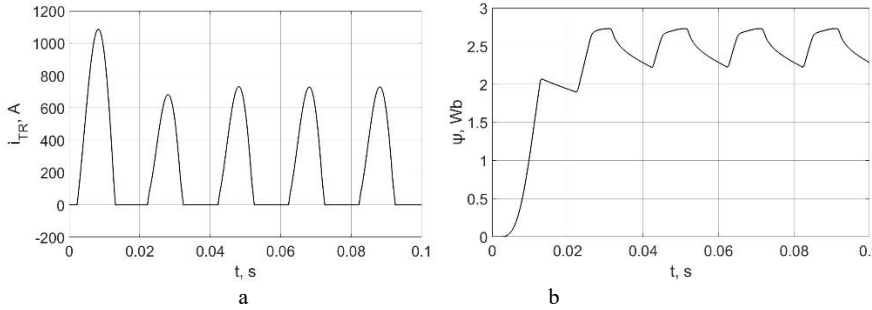

Fig. 7. Oscillograms of the ESP at a firing angle of 40°: a – TR current; b - flux linkage of transformer windings.

Fig. 8 shows current and voltage oscillograms under the condition $w_1 = 70\%$ and firing angle 90°. In this case, the consumed current was 322 A. As can be seen, the ESP voltage changes to a lesser extent due to an increase in the voltage drop across the current-limiting choke.

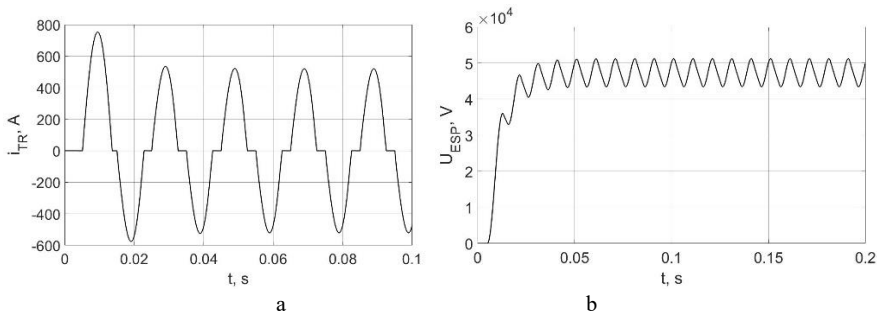

Fig. 8. Results for $w_1 = 70\%$ and a firing angle of 90°: a – TR current; b - voltage on the ESP.

As the simulation showed, at $w_1 = 70\%$ the “half-wave effect” appears even at firing angle $< 60^\circ$.

4 Conclusion

A study was made of operation of the «APTD-1000» unit when powering the ESP. By carrying out simulation of the ESP, taking into account the parameters of its elements, the current-voltage characteristic and the capacitance of the discharge gap of the ESP, the characteristics of operation of power supply of the ESP at various firing angles (90° , 45°) were obtained, providing a change in the consumed current from 241 up to 366 A and output voltage from 47.4 to 64.7 kV, as well as the values of the angles (e.g. 40° at $w_1 = 100\%$) at which the "half-wave effect" occurs. The obtained simulation results in the form of converter output voltage values correspond to the nominal parameters of «APTD-1000». (Table 1).

The work was supported by the grant for state support of young scientists of the Republic of Bashkortostan (NOC-GMU-2022).

References

1. G.M. Aliev, A.E. Gonik, *Power supply units for electrostatic precipitators* (Energy, Moscow, 1968)
2. K.N. Veremyev, H.K. Veremyev, Investigation of the Efficiency of Charging Aerosol Particles in a Powerful Electric Field by Numerical Simulation Methods. Bulletin of NF BSTU: mekhmat., **1**, 37-43 (2021)
3. B. Chen, H. Li, Y. He et al, Study on performance of electrostatic precipitator under multi-physics coupling, Environ. Sci. Pollut. Res., **26**, 35023–35033 (2019) doi:10.1007/s11356-019-06623-8
4. D. Yang, B. Guo, X. Ye, Numerical simulation of electrostatic precipitator considering the dust particle space charge, Powder Technology, **354**, 552-560 (2019) doi:10.1016/j.powtec.2019.06.013
5. M. Holubčík, J. Drga, N. Čajová Kantová et al, Optimization of Discharging Electrodes of a Multi-Chamber Electrostatic Precipitator for Small Heat Sources, Atmosphere, **14**, 63 (2023) doi:10.3390/atmos14010063
6. A.S. Serebryakov, V.L. Osokin, *Semiconductor power supplies for devices of electronic-ion technology* (NGIEU, Knyaginino, 2015)
7. G.N. Popa, I. Popa, V. Titihăzan, Simulations of the plate-type electrostatic precipitators high frequency power supplies using PSCAD/EMTDC 3.0.8 software, Ann. of Fac. Engin. Hunedoara, **2**, 115-120 (2004)
8. P.J. Villegas, J.A. Martín-Ramos, J. Díaz et al, A Digitally Controlled Power Converter for an Electrostatic Precipitator, Energies, **10**, 2150 (2017) doi:10.3390/en10122150
9. S.N. Vukosavić, Ž.V. Despotović, N. Popov et al, Multi resonant topology of ESP power: simulations and experimental results, Proc. 17th Int. Symp. Power Electronics, **1**, 1-5 (2013)
10. X. Cao, Simulation Research of Electrostatic Precipitator Power Supply Voltage Control System Based on Finite Element Differential Equation. Appl. Math. Nonl. Sc., (2022) doi:10.2478/amns.2022.2.0068

11. B. David, I.M. Shankarappa, B. Nerayanur, High voltage power supply controller for Electrostatic precipitators. *IJPEDS*, **13**, 432-443 (2022) doi:10.11591/ijpeds.v13.i1.pp432-443
12. G. Rajkumar, S. Sekar, Back corona elimination by a new intermittent pulsed power supply for electrostatic precipitators, *IAENG*, **29**, 1-10 (2021)
13. Manual. Device for automatic control of the power supply of electrostatic precipitators "SAPPHIREmp1". https://avtec.ru/_design/resapfir.pdf. Accessed 10 June 2023.
14. Catalog. Ramensky Electrotechnical Plant Energy. https://e-nova.ru/f/katalog_produkcii_retz_energiya.pdf. Accessed 10 June 2023.