

# Investigating The Determining Factors of Tourist Revisit Intention in a Natural-based Tourism Destination

*Indah Fatmawati*<sup>1,\*</sup> and *Frido Olga*<sup>2</sup>

<sup>1</sup> Doctor of Management Study Program, Universitas Muhammadiyah Yogyakarta, Bantul, DIY, Indonesia 55183

<sup>2</sup> Department of Management, Universitas Muhammadiyah Yogyakarta, Bantul, DIY, Indonesia 55183

**Abstract.** Tourism is one of the growing sectors in Indonesia. Natural-based tourism is one of the most attractive tourism destinations among various tourism types in Indonesia. Investigating factors influencing tourist revisit intention in a natural-based tourism destination is interesting since it could reveal what factors drive tourists to revisit a particular destination they have visited. This study aims to analyze the influence of environmental quality, attractiveness, accessibility, facilities, and tourist satisfaction on tourist objects' revisit intention. We use a quantitative approach and an explanatory design to test the proposed hypothesis. Respondents in this study were tourists who had visited Sarangan Lake, located in Magetan, East Java. The sampling method uses purposive sampling, and the final usable responses were 168 respondents. The analytical tool used in this research is Structural Equation Modelling (SEM) with the AMOS application program. Results indicated that environmental quality, attractiveness, accessibility, and facilities positively affect tourist satisfaction. Furthermore, tourist satisfaction positively impacts tourist revisit intention. Several research recommendations were discussed in our study.

## 1 Introduction

Tourism growth in Indonesia has been significant over the years, and the government has played a crucial role in fostering this development. Indonesia has diverse natural landscapes, stunning shorelines, lively coral ecosystems, and a cultural legacy. These attractions have been instrumental in attracting tourists. The Indonesian government has promoted these assets through various initiatives and campaigns[1]. The government has also significantly invested in improving infrastructure to support tourist growth. Developing airports, roads, and public transportation has enhanced connectivity and accessibility to tourist destinations. The government has encouraged private sector involvement in infrastructural projects to promote tourism and adopted policy reforms. Improved laws to attract foreign investment in the sector and promoted Indonesia as a tourism destination through worldwide campaigns, travel fairs, and internet marketing. It has announced Indonesia's attractions with travel brokers, airlines, and media. The government supports sustainable tourism and protects the environment and local populations. It has promoted ecotourism, community-based tourism, and sustainable tourism practices [1].

Research investigating the factors influencing tourist satisfaction and its consequences on revisit intention has yielded inconclusive findings in some cases, highlighting the complexity of these

---

\* Corresponding author: [indahfatmawati@umy.ac.id](mailto:indahfatmawati@umy.ac.id)

constructs and the diversity of tourist preferences. Several studies have reported mixed or inconclusive results regarding the influencing factors. [2] found a positive relationship between facilities and tourist satisfaction but was inconsistent across different facilities. [3] emphasized the impact of accessibility on tourists' decision-making process and satisfaction levels. Additionally, the availability and quality of facilities, including accommodation, transportation, and recreational activities, have been consistently linked to higher tourist satisfaction levels and a greater likelihood of revisit intention [4], [5]. [6] reported that destination attractiveness positively impacted tourist satisfaction but did not directly affect revisit intention. [7] found that environmental facilities, such as clean air and water, were positively associated with tourist satisfaction. Furthermore, destination attractiveness has been identified as a critical factor influencing tourist satisfaction and revisit intention [8]. [9] found that while environmental factors positively affected tourist satisfaction, they did not influence revisit intention.

The inconsistent findings show that setting, tourist segment, or other moderating variables may affect visitor satisfaction and revisit intention. Destination managers and politicians must understand these inconsistencies and contextual elements to meet tourists' needs and increase their happiness and likelihood of return. Environmental facilities, accessibility, tourism site appeal, and facilities are crucial to tourist pleasure and return. Destination managers may improve tourist experiences and encourage repeat visits and positive word-of-mouth by considering and enhancing the abovementioned aspects.

Concerning the importance of various influencing factors on tourist satisfaction and repeat visit intention, this study investigates the environmental quality, tourist destination attractiveness, tourist destination accessibility, and tourist destination facilities on tourist satisfaction and repeat visit intention. We chose a natural-based tourism destination, Sarangan Lake, located in Magetan, Regency East Java, Indonesia, as our research setting, involving visitors who attend this tourist destination as our respondents. This study's findings give better knowledge about factors influencing a natural-based tourism destination to revisit intention.

## **1.1 Literature Review**

This study is based on Ajzen 1991's Theory of Planned Behavior (TPB), a development of the Theory of Reasoned Action. According to Fishbein and Ajzen in 2011, TPB is a commonly used theory to predict and explain behavior associated with an activity. TPB states that the intention of individuals to behave in a certain way, such as revisiting tourist attractions, is a planned behavior that follows the satisfaction of tourists' expectations for environmental quality, attractiveness, accessibility, and facilities.

### **1.1.1 Environmental Quality**

Environmental quality is vital in shaping travelers' tourism experience and overall satisfaction. Environmental quality could cover aesthetic aspects, service quality and authenticity, and sustainable practices. Aesthetics such as pristine landscapes, clean air, and natural beauty contribute to tourists' satisfaction. Studies have shown that a positive perception of environmental quality enhances visitor satisfaction [10], [11]. Environmental aesthetics are associated with positive emotions, relaxation, and a sense of well-being, influencing tourists' experience evaluation. It is closely linked to service quality in the tourism industry.

Research has shown that tourists are more satisfied when they perceive environmentally responsible destinations [12], [13]. The natural and built environments in tourist destinations positively impact visitors' perceptions, enjoyment, and future intentions [10], [13], [14]. Tourists perceive higher service quality in destinations with better environmental quality [14]. Positive environmental attributes contribute to positive service encounters and higher satisfaction levels. Tourism locations must pursue sustainability to improve the environment. Waste management, energy saving, and responsible tourism improve the environment. Environmentally conscientious visitors are more satisfied with sustainable practices [11]. Positive eco-tourism experiences lead to repeat visits and referrals via tourism satisfaction.

### *1.1.2 Tourist Destination Attractiveness*

Destination's attractiveness shapes tourist satisfaction. It encompasses natural and cultural assets, amenities, and activities influencing visitor perceptions. Factors such as landscapes, heritage, recreation, infrastructure, and amenities contribute to destination attractiveness. Research consistently confirms that perceived attractiveness positively impacts tourist satisfaction [15], [16]. Aesthetic and culturally rich destinations enhance visitor satisfaction. Destination attractiveness improves experiential quality, encompassing sensory, emotional, and cognitive aspects. Well-designed attractions, immersive activities, and engaging experiences in attractive destinations increase tourist satisfaction [17], [18]. Memorable and enjoyable experiences in attractive destinations enhance satisfaction and create positive long-term memories.

Authenticity also plays a pivotal role in the appeal of tourist destinations. It's a significant factor in how tourists assess the attractiveness of a place. When cultural heritage, traditions, and local identity are preserved, it enhances the perceived authenticity of a destination. Studies have shown that destinations perceived as authentic tend to be more appealing to tourists, resulting in increased satisfaction [19], [20]. Authentic experiences provide a sense of novelty and uniqueness, fostering tourist satisfaction.

Effective destination marketing strategies are vital in shaping destination attractiveness and tourist satisfaction. Engaging marketing campaigns, online presence, and positive word-of-mouth (WOM) contribute to the perceived attractiveness of a destination [21], [22]. Marketing a destination's distinctive attractions, natural beauty, cultural offerings, and hospitality can boost tourist satisfaction. Tourism today needs sustainability measures to attract visitors. Tourism is increasing due to ecotourism, community engagement, and responsible tourism. Sustainable destinations conserve natural resources and cultural heritage and complement tourist ideals, improving satisfaction.

### *1.1.3 Tourist Destination Accessibility*

Tourism destination accessibility refers to how easily a destination can be reached and explored. It encompasses transportation networks, infrastructure, and travel services. Accessibility is vital for a destination's appeal and competitiveness, attracting tourists and enhancing their experiences. Previous research has shown a positive link between destination accessibility and tourist behavior. [23] found that improved accessibility positively influences tourists' decision-making process, making them more likely to choose a destination that offers convenient transportation options. Moreover, accessible destinations attract more tourists; as [24] demonstrated, destinations with better accessibility tend to experience increased visitation rates and more extended stays, ultimately leading to economic growth and job creation. Additionally, the World Tourism Organization (UNWTO) recognizes accessibility as one of the key factors contributing to inclusive and sustainable tourism development, as it enables people of all abilities to enjoy tourism experiences [25].

Previous studies showed tourists choose destinations that have convenient transit alternatives, such as well-connected airports and efficient public transportation systems [26]. The availability of accessible transportation influences tourists' perceptions of a destination's attractiveness and overall satisfaction. Tourists who perceived a destination as easily accessible reported higher satisfaction with their trip, highlighting the importance of convenient transportation options for enhancing their overall experience [27]. Another study [28] also emphasized the importance of destination accessibility for seniors, particularly in meeting their unique needs. Destinations that prioritize accessibility, including barrier-free facilities and age-friendly transportation systems, attract senior travelers and promote inclusive tourism experiences. [29] found that destinations with efficient transportation networks reduced the reliance on private vehicles, leading to lower carbon emissions and greater environmental sustainability. [30] found that easy access to transportation and amenities positively influenced tourists' perceptions of a destination, leading to higher satisfaction and repeat visitation. Examining the relationship between destination accessibility and tourist expenditures [31] indicated that improved accessibility positively influenced tourists' spending patterns, as tourists were likelier to engage in more activities and spend more money when convenient transportation options were available. [32] indicated that improved accessibility positively influences a destination's

competitiveness, as it enhances visitor satisfaction, increases the number of revisits, and stimulates positive WOM recommendations. Destinations with better accessibility have a competitive edge in attracting tourists and achieving sustainable tourism development.

#### *1.1.4 Tourist Destination Facilities*

Tourist destination facilities are crucial in influencing tourist satisfaction and revisit intention. Previous research has consistently emphasized these facilities' significance in shaping tourists' experiences and preferences to revisit a destination. [33] found that the quality and availability of facilities influenced tourists' overall satisfaction, highlighting the importance of well-maintained and diverse amenities. Tourism destination facilities are essential for attracting and satisfying tourists by enhancing their travel experience. Well-developed facilities play a significant role in the competitiveness and success of destinations. These include accommodations, restaurants, attractions, visitor centers, and recreational amenities [34]. [35] identified the quality and variety of tourism facilities as essential determinants. Destination facilities enhance the attractiveness of a place, increase visitor spending, and create employment opportunities, ultimately benefiting the local economy and community. [36] demonstrated that recreational facilities and attractions contributed to tourists' satisfaction and revisit intention. Moreover, [37] showed that diverse and well-maintained facilities positively affected tourists' perceived value, leading to higher satisfaction and repeat visitation. Similarly, [38] highlighted the importance of well-maintained transportation facilities in enhancing tourists' satisfaction and willingness to revisit. Furthermore, [39] reported that various facilities positively influenced tourists' perceived value, leading to higher satisfaction and intention to recommend the destination to others. Additionally, these facilities promote sustainable tourism by providing necessary infrastructure while minimizing negative environmental and cultural impacts [40].

To meet the needs of tourists, facilities need to be provided, starting from meeting the needs since departing from the place of residence of tourists while in tourist destinations, as well as when tourists return to their original site [24]. Tourist facilities should cater to visitors' needs at every stage of their trip, including before, during, and after their visit. Pre-visit facilities, like accessible information, are crucial in the digital age as tourists seek destination details. Road facilities should provide comfort and convenience for reaching tourist sites, and ample parking is essential during visits. Furthermore, accessible transportation hubs like terminals, stations, or airports facilitate tourists' return trips, making them vital post-visit facilities.

#### *1.1.5 Tourist Satisfaction*

Customer satisfaction is a feeling of disappointment or pleasure felt by someone arising from a comparison between performance and consumer expectations [25]. Satisfaction refers to the pleasure and sense of well-being derived from receiving what one expects from a desirable product or service. Research indicated that consumer satisfaction is determined by comparing expectations before and after consumption [2] [3] [4]. Unsatisfied customers have received lower than expected. Thus, customers will be unsatisfied if the goods and services do not meet or surpass their expectations. On the other hand, delighted visitors have had all their expectations met. Customers will be thrilled and delighted if the products' or services' performance exceeds their expectations [5] [6] [7].

Travelers will assess the extent to which their expectations are met. Visitor satisfaction results from overall visitor opinion on each destination's quality [28]. Several factors influence customer expectations, including customer needs, intentions, experience, friend recommendations, and marketing information. Prior expectations and post-trip experience influence tourism satisfaction [9] [10].

Tourism satisfaction is a crucial factor in the success and sustainability of the tourism industry. Previous research highlights the importance of satisfying tourists' needs and expectations, as it influences their overall travel experience, destination loyalty, and positive WOM recommendations. [44] reported that the quality of services, accommodations, attractions, and destination facilities influenced tourists' satisfaction levels. Moreover, the study highlighted the importance of

personalized and attentive customer service in enhancing overall satisfaction and fostering positive emotional experiences for tourists. [45] found a strong positive association between tourist satisfaction and their revisit intention. Additionally, it found that delighted tourists were more likely to engage in positive WOM communication, which can influence the reputation and success of a destination. Furthermore, (Chen et al., 2020) highlighted the crucial role of safety and hygiene measures in ensuring tourists' satisfaction and trust. It emphasized that destinations that prioritize and effectively communicate their health and safety protocols can enhance tourist satisfaction and foster long-term loyalty, even during challenging times.

### **1.1.6 Tourist Revisit Intention**

Tourist revisit intention represents an individual's willingness and readiness to repeatedly return to the same place. This concept is the most dependable predictor for revisit decisions, including purchasing vacation packages tailored for that particular destination [11]. Tourist revisit intention may be influenced by their appearance at the destination, as well as by promotional efforts and dissemination of news about new tourist attractions at the destination [37]. Several factors influencing tourist revisit intention are satisfaction during the visit, particular motivations in choosing tourist destinations, and tourists' love for destinations [38].

Tourist revisit intention is critical to destination success and sustainability. Previous research has shed light on the importance of understanding and influencing tourist revisit intention, as it directly impacts destination competitiveness, revenue generation, and long-term growth. [4] indicated that satisfaction with the destination experience, including the quality of services, attractions, and overall value for money, influenced tourists' revisit intention. Additionally, the study highlighted the role of destination image and emotional attachment in shaping tourists' intention to return. [18] indicated that tourists' perception of authenticity positively influenced their revisit intention, which enhanced their overall satisfaction and engagement with the cultural heritage experience. Furthermore, [7] highlighted the crucial role of a positive destination image and perceived value in shaping tourists' revisit intention. It emphasized the importance of delivering memorable experiences, providing value for money, and building a favorable destination image to attract tourists to revisit and foster destination loyalty.

## **1.2 Hypotheses Development**

### **1.2.1 The Effects of Environmental Quality on Tourist Satisfaction**

According to environmental psychology and the theory of place attachment, the quality of the environment plays a crucial role in shaping individuals' overall satisfaction and well-being [49], [50]. Regarding tourism, the environment encompasses various factors such as natural landscapes, built structures, cleanliness, safety, and accessibility [51]. Previous research has provided substantial evidence supporting the hypothesis that the quality of the environment affects tourist satisfaction. [52] found a positive impact on the perceived quality of the natural environment and visitor satisfaction. They concluded that enhancing the natural environment's quality positively influences tourist satisfaction. Additionally, [53] findings indicated that tourists who perceived the urban environment at a higher rate reported greater satisfaction with their overall travel experience. Furthermore, [54] found that the environment's cleanliness, aesthetics, and safety surrounding the heritage sites affect tourists' satisfaction.

The environment in tourist attractions impacts tourist satisfaction. A clean, neat, and comfortable environment positively influences satisfaction. When tourists see a well-maintained environment, they feel satisfied and perceive the community as caring for the environment. Additionally, residents' secure environment and hospitality increase visitor satisfaction with the attraction. Previous research by [12] proved that the environment positively affects satisfaction. Based on the earlier discussions, we developed the following hypothesis:

Hypothesis 1: Environmental quality positively affects tourist satisfaction.

### *1.2.2 The Effect of Tourist Destination Attractiveness on Tourist Satisfaction*

Each tourist attraction has its charm that is adjusted to the characteristics of the attraction. The increasing interest of tourists will cause satisfaction when visiting these attractions. Previous research showed that the quality of tourist attractions of natural tourist attractions, buildings, and social tourist attractions influences the satisfaction of foreign tourists [42]. According to destination attractiveness theory and the concept of cognitive appraisal, a tourist destination's perceived attractiveness impacts tourists' overall satisfaction and enjoyment of their travel experiences [60]. Previous research has consistently supported the hypothesis that tourist attractions affect tourist satisfaction. [61] demonstrated a positive and significant association between the perceived attractiveness of the beach destination and tourists' overall satisfaction. The study also highlighted that destination attractiveness was vital in shaping tourists' revisit intention. Additionally, [62] research findings indicated a positive relationship between the perceived attractiveness of the urban destination and tourist satisfaction. Furthermore, the study found that higher destination attractiveness positively influenced tourists' intentions to recommend the destination to others. Moreover, [63] examined the influence of destination attractiveness on tourist satisfaction and loyalty. The research demonstrated that perceived destination attractiveness affected tourist satisfaction levels. From the results of the study, the author proposes the following hypothesis:

Hypothesis 2: Tourist destination attractiveness positively influences tourist satisfaction.

### *1.2.3 The Effect of Tourist Destination Accessibility on Tourist Satisfaction*

According to theories of consumer behavior and economic psychology, accessibility plays a crucial role in shaping individuals' satisfaction with their consumption experiences [64], [65]. In tourism, accessibility refers to the perceived value for money, including the cost of transportation, accommodation, food, attractions, and other expenses associated with the travel experience [66]. Accessibility is a factor that tourists take into account when going to visit a tourist attraction. Good accessibility will determine whether or not the location is easy to reach [23]. Assessment of the level of accessibility of a tourist attraction will affect the level of tourist satisfaction. Meeting accessibility aspects such as transportation facilities, road conditions, road signs, and the availability of bicycle lanes will positively influence tourist satisfaction.

Previous research provides evidence supporting the hypothesis that tourist accessibility affects tourist satisfaction. For instance, a study by [68] indicated that tourists who perceived the destination as affordable and offered good value for money reported higher satisfaction levels. [69] revealed a positive correlation between tourist expenditure and overall satisfaction. The study highlighted that tourists who could afford more on their travel experiences tended to have higher satisfaction levels. [70] budget travelers who perceived their travel expenses as affordable and within budget constraints reported greater satisfaction with their travel experiences.

Hypothesis 3: Tourist destination accessibility positively influences tourist satisfaction.

### *1.2.4 The Effect of Tourist Destination Facilities on Tourist Satisfaction*

Facilities in tourist attractions must meet the needs of tourists while at the tourist site. According to [24], to meet the needs of tourist trips, facilities need to be provided, starting from meeting needs since departing from the place of residence of tourists while in tourist sites, as well as when tourists return to their original place, with the existence of complete, well-maintained, and able to meet the needs of tourists while in the tourist area will provide satisfaction for tourists. The feasibility of all facilities will also affect tourist satisfaction. [44] shows that facilities and services positively affect satisfaction because facilities and services are supporting factors in determining the volume of consumers/tourists in a tourist destination. Research conducted by [45] also showed that employee satisfaction with facilities in the office was related to perceived productivity support. A previous study [46] showed that facilities positively affect patients. The more complete the facilities a patient obtains, the more satisfied patients are with what they get. According to theories of service quality and

customer satisfaction, the availability and quality of facilities at a tourist destination play a crucial role in shaping tourists' overall satisfaction and enjoyment of their travel experiences [74], [75].

Previous research supports the hypothesis that tourist destination facilities affect tourist satisfaction. [33] indicated a positive relationship between the quality and availability of facilities, such as ski lifts, accommodations, and restaurants, and tourist satisfaction. Furthermore, [76] findings indicated that tourists who perceived the availability and quality of facilities, including museums, visitor centers, and transportation, to be satisfactory reported higher levels of overall satisfaction with their cultural tourism experiences. Additionally, [77] highlighted that the availability and quality of facilities, such as beach amenities, hotels, and restaurants, influenced tourist satisfaction. From the results of the study, the author proposes the following hypothesis:

Hypothesis 4: Tourist destination facilities positively influence tourist satisfaction.

### 1.2.5 The Effect of Tourist Satisfaction on Tourist Revisit Intentions

Customer satisfaction is a feeling of disappointment or pleasure felt by someone arising from a comparison between performance and consumer expectations [25]. Tourist satisfaction will affect the tourist's decision whether to revisit it. Satisfied travelers will compare it to their satisfaction when visiting other attractions. If tourists value greater perceived satisfaction, it will impact the emergence of intentions to make repeat visits. Visitor satisfaction results from overall visitor opinion on each destination's quality [28]. So, the satisfaction level of tourists affects the revisit intention. Research by [47] showed that overall satisfaction affected the revisit intention. The study also showed that tourists' satisfaction at the destination determines their revisit intention [13]. These discussions guided the author to propose the following hypothesis.

H5: Tourist satisfaction has a positive effect on tourist revisit intent.

The research model is shown in Figure 1.

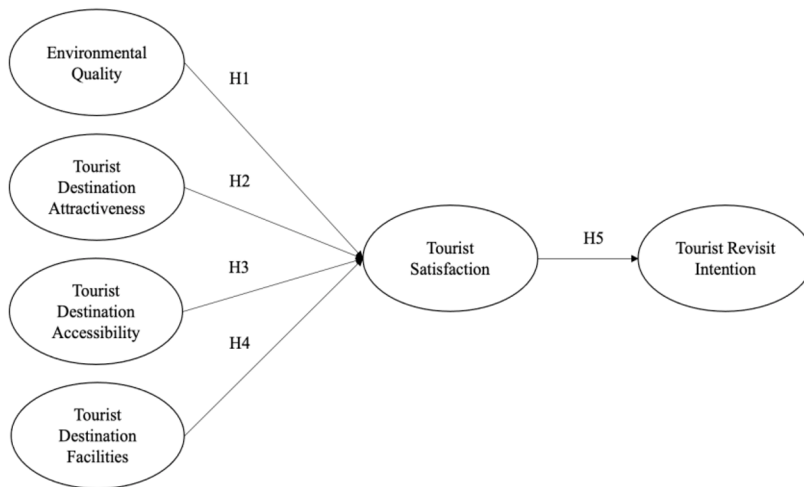

**Fig. 1.** Research Model

## 2 Research Method

The research method employed in this quantitative study utilizes explanatory research with survey data collection. The survey was conducted at Sarangan Lake, a tourism destination in East Java, Indonesia. The study involved 168 respondents who were visitors of Sarangan Lake and were selected using purposive sampling. Purposive sampling is a design limited to people who can provide information or meet criteria determined by the researcher [61]. Purposive sampling was chosen to ensure that the selected participants met specific criteria relevant to the study's objectives. In this

study, researchers have chosen the following requirements: have visited Sarangan Lake, aged 17 years or above. The survey instrument consisted of a structured questionnaire to gather data on various variables related to tourist satisfaction and their revisit intention. This study includes the environment, attractiveness, accessibility, and facilities in exogenous variables. The mediating variable in this study was tourist satisfaction. In this study, the endogenous variable is the revisit intention. The collected survey data will be analyzed to examine relationships, patterns, and potential explanations for tourist satisfaction antecedents and consequences. The findings from this study will contribute to a deeper understanding of the factors influencing tourist satisfaction and provide valuable insights for destination management and development.

### 3 Results

**Table 1.** Respondents Demographic Characteristics

Demographic Characteristics	Classifications	Total	Percentage (%)
Age	17-24	117	69.6
	25-34	7	4.2
	35-44	13	7.7
	>45	31	18.5
	Total	168	100
Gender	Male	92	54.8
	Female	76	45.2
	Total	168	100
Province/City of Origin	West Java	3	1.8
	East Java	133	79.2
	Central Java	18	10.7
	D.I Yogyakarta	3	1.8
	East Kalimantan	3	1.8
	Papua	3	1.8
	Jakarta	1	0.6
	South Kalimantan	3	1.8
	Ambon	1	0.6
	Total	168	100
Occupation	Student	92	54.8
	Self Employed	25	14.9
	Civil servants	28	16.7
	TNI/POLRI	4	2.4
	Employee	8	4.8
	Housewives	2	1.2
	Others	9	5.4
	Total	168	100
Monthly Income	<IDR 3.000.000	120	71.4
	IDR 3.000.000 – <IDR 5.000.000	30	17.9
	=>IDR 5.000.000	18	10.7
	Total	168	100
Visiting Frequencies	1	26	15.5
	2	7	4.2
	3	4	2.4
	>3	131	78.0
	Total	168	100
Tourism Source of Information	Social Media	37	22
	Friend	118	70.2
	Family	4	2.4
	Others	9	5.4
	Total	168	100



After several weeks of the Google form distribution, we received 168 final usable responses. The description of the demographic of respondents is shown in Table 1. Table 1 shows that most respondents are 17-24 years old and live in East Java. Most of them are students with a monthly income of less than IDR 1,000,000 and have visited Sarangan Lake more than three times and heard the destination information from friends.

### 3.1 Instrument Testing

Validity and reliability are essential for research instruments. We continue the data processing with instrument testing, including validity and reliability tests. We tested the construct validity to test how well an instrument is intended to measure, while reliability is used to test how consistent the measuring instrument is. This study uses IBM SPSS AMOS version 22 to examine 168 respondents' instrument quality using 30 statements representing all variables [14].

**Table 2.** Validity and Reliability Test Results

Variable	Item	Loading Factor	Construct Reliability
Environmental Quality	Well-maintained environmental conditions	0.635	0.8701
	Clean housing conditions	0.801	
	The Lake environment condition is clean	0.744	
	Water conditions in clean settlements	0.755	
	Safe environment	0.840	
Tourist Destination Attractiveness	Sarangan Lake is an exotic place	0.821	0.8870
	Beautiful view	0.712	
	Affordable ticket prices	0.750	
	Comfortable weather/climate	0.814	
	Favorite attractions	0.808	
Tourist Destination Accessibility	Easy to reach	0.808	0.8794
	Good road conditions	0.783	
	Safe roads to walk	0.735	
	Public transportation available	0.734	
	Directions available	0.790	
Tourist Destination Facilities	Adequate number of lodgings	0.792	0.8860
	Restaurants are easy to find	0.792	
	Toilets are accessible to find	0.769	
	Information counter availability	0.739	
	Adequate parking area	0.808	
Tourist Satisfaction	I am delighted to be visiting	0.786	0.9204
	Satisfied with the quality of the lodging	0.824	
	Satisfied with the officer's service	0.884	
	Satisfied with road conditions	0.821	
	Satisfied with cleanliness	0.861	
Tourist Revisit Intention	Will become the first choice	0.772	0.9029
	Will visit next time	0.817	
	Possible to revisit	0.791	
	Will visit more often	0.796	
	Will stay longer	0.855	

Table 2 shows the results of validity and reliability testing. It indicated that each item has a loading factor higher than 0.5 for validity, meaning it is a valid instrument. The reliability testing results showed that all six variables tested for reliability were reliable, based on the magnitude of CR greater

than 0.70. According to [15] cut-off value of the Construct Reliability (CR) to find reliable data is 0.7 [15].

### 3.2 Normality and Outlier Test

The critical ratio value (C.R) for kurtosis (showing pointedness) and skewness (representing asymmetry) within the range of -2.58 to 2.58 was determined using a normality test. When a value surpasses a crucial threshold, the data's univariate distribution is not normally distributed [15]. The critical ratio (C.R.) values for kurtosis (pointiness) and skewness (astonishment) are in the range of -2.58 to 2.58, indicating that the majority of univariate normality tests are normally distributed. Because the value of -1.334 ranges from -2.58 to 2.58, multivariate data meets standard assumptions.

Data that exhibit distinctive features that differ in appearance from other observations or take extreme forms are called outliers. A significance level of  $p < 0.001$  was used to examine the Mahalanobis Distance Squared value to test the presence of outliers [15]. Our study uses 30 statement items. The result is 59.703, meaning that all cases whose value is greater than 59,703 are multivariate outliers. The 94th respondent with a d-squared Mahalanobis value of 52,939 is the highest d-squared Mahalanobis value. Thus, no data is greater than 59,703, and no outliers exist.

### 3.3 Goodness of Fit Test

Our following phase assesses goodness-of-fit, which identifies the degree to which the proposed model fits the data [15]. Table 3 displays the Goodness of Fit test results.

**Table 3. The Goodness of Fit Test Result**

The goodness of the fit index	Cut-off value	Research Model	Model
Significant probability	$\geq 0.05$	0.000	Marginal Fit
Chi-Squares	441.282 (df=394)	509.155	Marginal Fit
RMSEA	$\leq 0.08$	0.042	Good Fit
GFI	$\geq 0.90$	0.840	Marginal Fit
AGFI	$\geq 0.80$	0.811	Marginal Fit
CMIN/DF	$\leq 2.00$	1.292	Good Fit
TLI	$\geq 0.90$	0.963	Good Fit
CFI	$\geq 0.90$	0.967	Good Fit

The RMSEA, CMIN/DF, TLI, and CFI, as shown in Table 3, all point to a satisfactory fit. According to the principle of parsimony, the model is good overall if one or both requirements are satisfied. Given that the data fit the suggested model, the goodness-of-fit test results.

### 3.4 Hypothesis Testing

The subsequent phase involves the interpretation and estimation of the model. Figure 2 below displays the estimation of the final model. LI stands for Environmental Quality, DT for Destination Attractiveness, KJ for Destination Accessibility, FA for Destination Facilities, KP for Tourist Satisfaction, and NI for Tourist Revisit Intention.

Figure 2 shows the final model estimation of the direct influence values between variables. The direct relationship between variables is shown in Table 4.

Based on Table 4, our hypothesis testing yielded these results. The first hypothesis's estimated value is 0.517, showing that tourism satisfaction rises with environmental quality. A P value of 0.000, less than 0.05, supports this result. Thus, Hypothesis 1, that environmental quality increases visitor happiness, is supported.

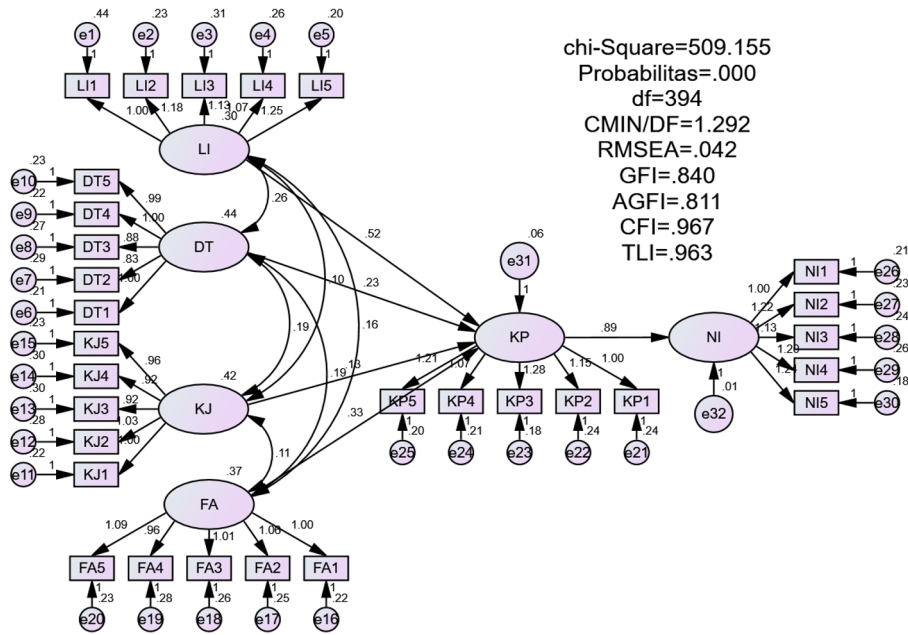

**Fig. 2.** *Direct Effect Variable*

**Table 4. Relationship between Variables**

No	Hypothesis	Estimate	P	Border	Note
1.	Environment Quality→Tourist Satisfaction (H1)	0.517	0.000	0.05	Supported
2.	Tourist Destination Attractiveness→ Tourist Satisfaction (H1)	0.228	0.001	0.05	Supported
3.	Tourist Destination Accessibility → Tourist Satisfaction (H3)	0.129	0.006	0.05	Supported
4.	Tourist Destination Facilities → Tourist Satisfaction (H4)	0.326	0.000	0.05	Supported
5.	Tourist Satisfaction Tourist Revisit Intention (H5)	0.888	0.000	0.05	Supported

The second hypothesis' calculated value is 0.228, suggesting a link between tourist attraction appeal and satisfaction. This finding shows that tourists are more satisfied at more enticing destinations. A substantial link is indicated by the P value of 0.01, less than 0.05. Thus, Hypothesis 2, that visitor satisfaction increases with tourism location appeal, is validated.

Our third hypothesis test showed an estimated value of 0.129. This result indicates that tourism location accessibility increases visitor satisfaction. A P value of 0.006, below 0.05, indicates a substantial connection. Hypothesis 3, that tourist destination accessibility affects visitor satisfaction, is supported, suggesting that more accessible access to a tourist attraction increases visitor contentment.

Our estimated value for the fourth hypothesis is 0.326. It suggests that greater tourism destination amenities increase visitor satisfaction. P = 0.000 indicates significance. Thus, Hypothesis 4 is supported, demonstrating that improved tourism destination facilities increase visitor contentment and that better tourism destinations have higher satisfaction.

Our fifth hypothesis showed a positive correlation between visitor satisfaction and the intention to return, with an estimated value of 0.888. This finding suggests that tourist satisfaction increases the intent to return. Results with P values of 0.000 (below 0.05) are significant. Thus, Hypothesis 5,

that tourist satisfaction strongly affects tourist revisit intentions, is validated, showing that higher tourist contentment increases the likelihood of returning to the destination.

## **4 Discussion**

The results of our first hypothesis testing revealed that environmental quality positively influenced tourist satisfaction at Sarangan Lake. These findings are consistent with earlier research [4], showing a positive effect of environmental variables on satisfaction. This finding aligns with earlier studies on the impact of environmental elements on tourist experiences. Previous research found a similar positive relationship, demonstrating that tourists who perceived the surroundings as clean, well-maintained, and aesthetically pleasant reported higher satisfaction [81]. [82] examined the effect of environmental quality on tourist satisfaction in a national park setting. The findings showed a substantial positive link between the two variables, indicating that a high-quality environment improves tourist pleasure. The ramifications of these findings for destination management and planning are significant. Recognizing the favorable impact of environmental quality on tourist satisfaction, destination management can concentrate on improving and protecting the natural and constructed environments. This effort may include trash management, cleanliness, infrastructure upkeep, and strategies for sustainable growth.

Hypothesis 2 research findings indicate a favorable association between tourism location attractiveness and tourist satisfaction. This finding supported prior studies on the impact of destination attractiveness on tourist experiences. [83] examined the effect of tourist destination attractiveness on tourist satisfaction in a popular cultural destination. Their findings supported the positive relationship between destination attractiveness and visitor satisfaction, indicating that tourists who viewed the destination as aesthetically pleasing, culturally diverse, and offering various activities reported higher satisfaction levels. This result is also consistent with prior research highlighting the significance of destination attractiveness in shaping tourist experiences. A previous urban tourism study examined how destination appeal influences tourist satisfaction, finding a positive link, indicating that an attractive destination enhances tourist satisfaction [84]. This study confirms that greater natural attraction in tourism improves tourist satisfaction. Appeals are categorized into natural and artificial, with natural attractions encompassing features like scenery and climate and their location or presence. Artificial interests include monuments, festivals, and local arts. Tourist satisfaction increases with the diversity and complexity of attractions [16]. These results have practical implications for destination management and marketing. Acknowledging the importance of destination appeal in shaping tourist satisfaction, destination managers can prioritize improving visual aesthetics, cultural richness, and various activities in their locales. This effort entails investments in infrastructure, preservation of historical sites, enhancement of tourist facilities, and promotion of distinctive experiences.

The research supports hypothesis 3, indicating a positive link between tourist destination accessibility and satisfaction, in line with prior studies on accessibility's influence on tourist experiences. [85] explored the impact of destination accessibility on tourist satisfaction in a rural tourism setting. Their results confirmed a positive relationship, showing that tourists who perceived the destination as easily accessible, with good transportation infrastructure and convenient travel options, reported higher satisfaction [85]. The present research backs hypothesis 3, asserting that destination accessibility positively impacts satisfaction, consistent with prior studies emphasizing accessibility's role in shaping tourist experiences. [86] Studies indicated a positive relationship between destination accessibility and tourist satisfaction. Convenient access to a destination enhances overall tourist satisfaction [86]. The results of this study prove that the level of accessibility of a tourist attraction will affect tourist satisfaction. Good accessibility will determine whether or not the location is easy to reach [5]. Distance, lodging, road quality, and ease of reach affect tourist pleasure by making sites simple. Travelers plan around accessibility. These findings can help destination managers and policymakers improve satisfaction by investing in transportation infrastructure, clear travel information, connectivity, transportation networks, signage, digital platforms, and transportation provider partnerships.

Hypothesis 4 results also support a positive relationship between destination attractiveness and tourist satisfaction, aligning with previous research on the impact of destination appeal on tourist experiences. This study aligns with a study conducted by [83] that supported a similar positive relationship, indicating that tourists who perceived the destination as visually appealing, culturally rich, and offering a variety of activities reported higher levels of satisfaction [83]. [84] examined the impact of destination attractiveness on tourist satisfaction in an urban tourism context. The results indicated a positive relationship between destination attractiveness and tourist satisfaction, supporting that an attractive destination contributes to higher tourist satisfaction levels [84]. These findings have practical implications for destination management and marketing. Recognizing the significance of destination attractiveness in influencing tourist satisfaction, destination managers can focus on enhancing the visual appeal, cultural assets, and range of activities in their destinations. This effort involves investments in infrastructure, preservation of historical sites, development of tourist amenities, and promotion of unique experiences.

The finding of hypothesis 5 testing suggests a positive relationship between tourist satisfaction and tourist revisit intentions. This finding is consistent with previous research that has examined the influence of satisfaction on revisit intentions. [87] results supported a similar positive relationship, indicating that higher tourist satisfaction levels were associated with a greater likelihood of revisiting the destination [87]. [83] the authors explored the influence of satisfaction on reviewing intentions in a cultural heritage destination. The results indicated a positive relationship between satisfaction and revisit intentions, supporting that satisfied tourists are more likely to revisit a destination [83]. These results hold practical significance for destination management and marketing. Acknowledging the connection between satisfaction and the likelihood of visitors returning, stakeholders can concentrate on providing outstanding visitor experiences to raise satisfaction and promote repeat visits. This endeavor may enhance service quality, elevate customer interactions, and deliver personalized experiences.

## **5 Conclusions, Limitations and Suggestions**

The following are our conclusions based on the data analysis. Environment quality increases tourist satisfaction. According to the first hypothesis test, environmental quality increases tourist satisfaction at Sarangan Lake. This finding supports earlier studies showing a favorable association between environmental variables and satisfaction. These findings suggested destination management, stressing waste management, cleanliness, infrastructure maintenance, and sustainable development to improve and preserve the natural and built environment.

Tourism destination attractiveness increases tourist satisfaction. This association support previous studies with comparable results. Our results indicate that destination attractiveness shapes tourist experiences. Investing in infrastructure, maintaining historical buildings, expanding tourist amenities, and marketing unique experiences can improve destinations' visual attractiveness, cultural assets, and range of activities, boosting tourist satisfaction.

Our results also showed that tourism location accessibility increases tourist satisfaction. Earlier investigations found a similar link. Our findings show that destination accessibility affects tourist satisfaction. Destination managers must improve transportation infrastructure, travel information, and connectivity to attract and keep tourists. Investments in transportation networks, signage, digital platforms, and transportation provider coordination can improve destination accessibility and tourist satisfaction.

Our hypothesis four testing results indicated that tourist destination attractiveness increases tourist satisfaction. Our study shows that destination appeal affects tourist satisfaction. Investing in infrastructure, maintaining historical buildings, expanding tourist amenities, and marketing unique experiences can improve destinations' visual attractiveness, cultural assets, and range of activities, boosting tourist satisfaction.

Finally, our hypothesis five testing reported a favorable association between visitor satisfaction and revisit intentions, supporting earlier studies. These studies underscore the relevance of satisfaction in repeating visits. For destination administrators and marketers, providing exceptional guest

experiences boosts satisfaction and encourages repeat visits. This effort may involve improving service quality, customer interactions, and tailored experiences to increase tourist satisfaction and return visits.

Sarangan Lake is a popular tourist destination in East Java that is accessible and has various tourist attractions. However, there is a conception that the tourist. Satisfaction in visiting Sarangan Lake still needs to be higher than visiting other attractions. This study only considers four antecedents of tourist satisfaction. Future research still has the opportunity to develop a more comprehensive research variable to be considered.

## References

1. Indonesia Investments, "Tourism in Indonesia: The Role of the Government." (2021).
2. C. G., Chi, and H. Qu, "Examining the structural relationships of destination image, tourist satisfaction, and destination loyalty: An integrated approach," *Tour Manag*, vol. 29, no. 4, pp. 624–636, (2008).
3. D. Gursoy, L. Lu, and A. C. C. Lu, "Antecedents and outcomes of travelers' information search for alternative restaurants," *J Travel Res*, vol. 55, no. 5, pp. 587–602, (2016).
4. Chen. C.F., "Factors influencing tourists' satisfaction and loyalty in the green island resort: An integrated model of sustainable tourism," *Journal of Sustainable Tourism*, vol. 25, no. 7, pp. 931–950, (2017).
5. A. Yüksel and F. Yüksel, "Shopping risk perceptions: Effects on tourists' emotions, satisfaction and expressed loyalty intentions," *J Travel Res*, vol. 45, no. 3, pp. 269–280, (2007).
6. C. F. Chen and D. Tsai, "The influence of destination image and tourist satisfaction on tourist loyalty: A case study of Chinese tourists in Korea," *Journal of Travel & Tourism Marketing*, vol. 35, no. 3, pp. 590–605, (2018).
7. J. W. Kim, W. G. Kim, and C. K. Lee, "The Impact of Destination Image and Perceived Value on Destination Satisfaction and Revisit Intention: Moderating Role of Destination Type," *J Travel Res*, vol. 57, no. 6, pp. 731–744, (2018).
8. A. García-Mas, A. B. Ramón-Rodríguez, and M. Á. Fernández-Izquierdo, "Destination attractiveness, tourist satisfaction, and destination loyalty: A study in the context of cultural tourism," *Sustainability*, vol. 11, no. 1, p. 3011, (2019).
9. D. Wang, S. Lee, and H. H. Hu, "Investigating the impact of tourist satisfaction on revisiting and recommending a destination with a modified gravity model," *J Travel Res*, vol. 59, no. 3, pp. 465–482, (2020).
10. D. W. Ko, W. P. Stewart, and H. Han, "A structural equation model of residents' attitudes for tourism development," *Tour Manag*, vol. 33, no. 5, pp. 1261–1270, (2012).
11. J. Ap, "Residents' perceptions on tourism impacts," *Ann Tour Res*, vol. 19, no. 4, pp. 665–690, (1992).
12. D. Weaver, "Sustainable tourism: Theory and practice. Channel View Publications," (2005).
13. S. Dolnicar, "Tourism and water: Interactions and impacts," *Channel View Publications*, 2010.
14. Y. Li, C. K. Cheng, and W. Guo, "The effect of environmental quality on destination loyalty: The mediating role of destination service quality," *Journal of Sustainable Tourism*, vol. 29, no. 7, pp. 1036–1055, (2021).
15. J. F. Petrick, "The roles of quality, value, and satisfaction in predicting cruise passengers' behavioral intentions," *J Travel Res*, vol. 42, no. 4, pp. 397–407, (2004).
16. A. Beerli and J. D. Martin, "Factors influencing destination image," *Ann Tour Res*, vol. 31, no. 3, pp. 657–681, (2004).

17. I. Frochot and A. Morrison, "The measurement of service quality in the tour operating sector: A methodological comparison," *J Travel Res*, vol. 38, no. 3, pp. 291–296, (2000).
18. W. G. Kim and H. B. Kim, "The Relationship between Perceived Authenticity and Intention to Revisit Cultural Heritage Sites: The Mediating Role of Tourist Satisfaction," *Journal of Sustainable Tourism*, vol. 25, no. 6, pp. 761–776, (2017).
19. S. K. Nepal and D. J. Timothy, "Authenticity in tourism: Transformational quests and engagements," *Channel View Publications*, (2014).
20. D. Wang, X. Li, and P. Xie, "Destination authenticity and tourist satisfaction: The mediating role of perceived value," *J Travel Res*, vol. 60, no. 4, pp. 786–801, (2021).
21. D. Buhalis and M. Foerste, "SoCoMo marketing for travel and tourism: Empowering co-creation of value," *Journal of Destination Marketing & Management*, vol. 4, no. 3, pp. 151–161, (2015).
22. W. G. Kim and J. Agrusa, "The impact of electronic word-of-mouth on destination attractiveness: Visitors' Facebook comments," *J Travel Res*, vol. 57, no. 7, pp. 851–868, (2018).
23. C. F. Chen and F. S. Chen, "Experience quality, perceived value, satisfaction and behavioral intentions for heritage tourists," *Tour Manag*, vol. 42, pp. 35–48, (2014).
24. B. Faulkner, M. Oppermann, and L. Fredline, "Destination attractiveness: A model of antecedents and intentions," *J Travel Res*, vol. 54, no. 5, pp. 581–595, (2015).
25. UNWTO, *International Tourism Highlights, 2019 Edition*. World Tourism Organization (UNWTO), (2019). doi: 10.18111/9789284421152.
26. S. Baloglu and K. W. McCleary, "A model of destination image formation," *Ann Tour Res*, vol. 26, no. 4, pp. 868–897, (1999).
27. D. Gursoy, C. Jurowski, and M. Uysal, "Resident Attitudes: A Structural Modeling Approach," *Ann Tour Res*, vol. 29, no. 1, pp. 79–105, (2002).
28. B. McKercher, P. Ho, and H. Du Cros, "Relationship between tourism and quality of life: evidence from a cross-regional study in China," *Tour Manag*, vol. 26, no. 5, pp. 691–701, (2005).
29. C. M. Hall and S. J. Page, "Tourism in South and Southeast Asia: Issues and Cases. Amsterdam, Netherlands: Elsevier," (2006).
30. D. Dredge and J. Jenkins, "Tourism and Hospitality in the 21st Century. Oxford, UK: Butterworth-Heinemann," (2007).
31. B. Prideaux and S. S. Kim, "Tourism in Northeast Asia: Issues and Cases. Amsterdam, Netherlands: Channel View Publications," (2010).
32. S. Saha, P. Kar, and S. Das, "Accessibility and destination competitiveness: An empirical investigation of the Indian tourism industry," *Journal of Hospitality and Tourism Management*, vol. 35, pp. 141–151, (2018).
33. M. Kozak and M. Rimmington, "Tourist Satisfaction with Mallorca, Spain, as an Off-Season Holiday Destination," *J Travel Res*, vol. 38, no. 3, pp. 260–269, (2000).
34. D. Buhalis and E. Michopoulou, "Tourism on the Greek Island of Crete: Implications for Seasonality and Sustainability," *Journal of Sustainable Tourism*, vol. 9, no. 5, pp. 422–442, (2001).
35. J. R. Ritchie and G. I. Crouch, "The Competitive Destination: A Sustainable Tourism Perspective. Wallingford, UK: CABI Publishing," (2003).
36. D. Gursoy, K. Kim, and M. Uysal, "Perceived impacts of festivals and special events by organizers: An extension and validation," *Tour Manag*, vol. 25, no. 2, pp. 171–181, (2004).
37. Y. Choi, X. Lehto, and A. M. Morrison, "Destination Image Representation on the Web: Content Analysis of Macau Travel Related Websites," *Tour Manag*, vol. 28, no. 1, pp. 118–129, (2007).
38. J. T. Coshall and A. Charlesworth, "The influence of transport integration on the satisfaction and travel behavior of tourists visiting a remote rural area," *Journal of Sustainable Tourism*, vol. 17, no. 6, pp. 709–728, (2009).

39. D. Gursoy, C. G. Q. Chi, and L. Lu, "Antecedents and Outcomes of Tourists' Emotional Experiences: The Case of Game Tourists," *Tour Manag*, vol. 36, pp. 202–219, (2013).
40. M. García-Martin, D. Jiménez-Fernández, and M. Celdrán-Bernabeu, "Sustainability in Tourist Destinations: An Analysis of European Union Countries," *Sustainability*, vol. 11, no. 15, p. 4079, (2019).
41. L. M. , & O. V Suryadana, "Introduction to Tourism Marketing. Bandung," (2015).
42. P. , & K. Kotler, *Marketing Management*, 14th ed. (2014).
43. G. Prayag, "Senior travelers' motivations and future behavioral intentions: The case of Nice," *Journal of Travel & Tourism Marketing*, (2012).
44. M. E. Hossain and M. M. Anwar, "Tourist Satisfaction and Destination Loyalty: A Study of Sylhet, Bangladesh," *Journal of Travel and Tourism Marketing*, vol. 30, no. 1–2, pp. 23–46, (2013).
45. X. Li and X. Li, "Tourist Satisfaction, Destination Loyalty, and Destination Image: Evidence from Hong Kong," *J Travel Res*, (2019).
46. C. F. Chen, K. Hung, and J. F. Petrick, "The Impact of COVID-19 Pandemic on International Tourist Satisfaction and Destination Loyalty: A Perspective of Bangladeshi Tourists," *J Travel Res*, (2020).
47. N., A. A. A. M., O. N. A., & E. C. Abd Aziz, "Examining the impact of visitors' emotions and perceived quality towards satisfaction and revisit intention to theme parks (Kajian Kesan Emosi dan Tanggapan Kualiti Pengunjung Terhadap Kepuasan dan Hasrat Berkunjung Semula Ke Taman Tema)," *Jurnal Pengurusan (UKM Journal of Management)*, (2012).
48. J., & C. M. Alegre, "Analysing the effect of satisfaction and previous visits on tourist intentions to return," *Eur J Mark*, (2009).
49. K. Korpela and T. Hartig, "Restorative qualities of favorite places," *J Environ Psychol*, vol. 16, no. 3, pp. 221–223, (1996).
50. D. R. Williams and J. J. Vaske, "The measurement of place attachment: Validity and generalizability of a psychometric approach," *Forest Science*, vol. 49, no. 6, pp. 830–840, (2003).
51. J. Hultman and A. Törn, "Urban tourism destination image, satisfaction, and behavioral intentions: The effects of the environment quality in the Swedish city of Gävle," *Scandinavian Journal of Hospitality and Tourism*, vol. 121, pp. 39–58, (2012).
52. M. Sirgy, G. B. Yu, and C. Su, "Destination image, self-congruity, and travel behavior: Toward an integrative model," *J Travel Res*, vol. 38, no. 4, pp. 340–352, (2000).
53. X. Rong, H. Li, S. Liu, and C. Li, "Influence of urban environment quality on tourist satisfaction: A study of heritage tourism in Guangzhou, China," *Sustainability*, vol. 11, no. 15, p. 4231, (2019).
54. T. H. Lee, F. H. Jan, J. S. Chen, and C. L. Lee, "The relationship between environmental quality and tourist satisfaction at cultural heritage sites," *Current Issues in Tourism*, vol. 219, pp. 1077–1092, (2018).
55. S. M., & T. Z. Dawal, "The Effect of Job and Environmental Factors on Job Satisfaction in Automotive Industries," (2006).
56. S. W., & X. K. Lee, "A model of destination loyalty: integrating destination image and sustainable tourism," (2020).
57. K. Hallmann, A. Zehrer, and S. Müller, "Perceived Destination Image: An Image Model for a Winter Sports Destination and Its Effect on Intention to Revisit," *J Travel Res*, vol. 54, no. 1, pp. 94–106, Jan. (2015)
58. Suwanto, *Dasar-Dasar Pariwisata*. (2000).
59. R., & R. H. A. Basiya, "Kualitas daya tarik wisata, kepuasan dan niat kunjungan kembali wisatawan mancanegara di jawa tengah. Jurnal Ilmiah Dinamika Kepariwisata," vol. 11, no. 2, (2012).



60. R. Govers and F. M. Go, "Place Branding: Glocal, virtual and physical identities, constructed, imagined and experienced," *Palgrave Macmillan*, (2009).
61. S. Lee and S. Kim, "The impact of destination attractiveness on tourist satisfaction and intention to revisit: The moderating role of authenticity," *Journal of Destination Marketing & Management*, vol. 19, (2021).
62. J. E. Bigne, M. I. Sanchez, and J. Sanchez, "Destination attractiveness, satisfaction, and loyalty: An integrated model for mature tourism destinations," *J Travel Res*, (2020).
63. S. Baloglu and D. Brinberg, "Affective images of tourism destinations," *J Travel Res*, vol. 35, no. 4, pp. 11–15, (1997).
64. R. Dhar and K. Wertenbroch, "Consumer choice between hedonic and utilitarian .ods." *Journal of Marketing Research*, vol. 37, no. 1, pp. 60–71, (2000).
65. V. A. Zeithaml, "Consumer Perceptions of Price, Quality, and Value: A Means-End Model and Synthesis of Evidence," *J Mark*, vol. 52, no. 3, pp. 2–22, Jul. (1988)
66. S. W. Litvin, R. E. Goldsmith, and B. Pan, "Electronic word-of-mouth in hospitality and tourism management," *Tour Manag*, vol. 29, no. 3, pp. 458–468, (2008).
67. I. G. A. , W. I. G. A. , & A. I. B. M. Sumarabawa, "Ketersediaan Aksesibilitas Serta Sarana dan Prasarana Pendukung Bagi Wisatawan Di Daerah Wisata Pantai Pasir Putih, Desa Prasi, Kecamatan Karangasem," *Jurnal Pendidikan Geografi Undiksha*, (2015).
68. K. S. Chon and M. D. Olsen, "Functional and symbolic approaches to consumer satisfaction/dissatisfaction in tourism," *J Travel Res*, vol. 30, no. 4, pp. 10–16, (1991).
69. A. Pizam and Y. Mansfeld, "Tourism, crime, and international security issues," *J Travel Res*, vol. 45, no. 3, pp. 213–224, (2006).
70. E. Woo and H. K. Fock, "The effect of tourists' perceived accessibility on satisfaction with a budget travel destination," *J Travel Res*, vol. 54, no. 1, pp. 87–101, 2(015).
71. N., & N. D. Hayati, "An Analysis of Tourism Service Quality Toward Customer Satisfaction (Study on tourists in Indonesia travel destinations to Bali)," *International Journal of Marketing and Human Resource Management*, (2017).
72. B., van der V. T., H. B., & van S. H. Groen, "Impact of employee satisfaction with facilities on self-assessed productivity support," *Journal of Facilities Management*, (2019).
73. G. & K. I. Surasdiman, "Analisis Pengaruh Kualitas Pelayanan, Fasilitas dan Pengetahuan terhadap Kepuasan Pasien di Puskesmas Batu-Batu Kabupaten Soppeng," (2019).
74. A. Parasuraman, V. A. Zeithaml, and L. L. Berry, "SERVQUAL: A multiple-item scale for measuring consumer perceptions of service quality," *Journal of Retailing*, vol. 64, no. 1, pp. 12–40, (1988).
75. V. A. Zeithaml, M. J. Bitner, and D. D. Gremler, "Services marketing: Integrating customer focus across the firm," *McGraw-Hill Education*, (2021).
76. Z. Xiang, Q. Du, Y. Ma, and W. Fan, "Destination image and tourist loyalty: A meta-analysis," *Tour Manag*, vol. 58, pp. 242–253, (2017).
77. D. Buhalis and E. Michopoulou, "Information-enabled tourism destination marketing: A case study of the island of Mykonos, Greece," *J Travel Res*, vol. 50, no. 6, pp. 559–569, (2011).
78. U. A., & G. H. Ozturk, "Destination attributes, satisfaction, and the cruise visitor's intent to revisit and recommend." (2016).
79. Sekaran & Bougie, *Research methods for business: a skill-building approach – 6th ed*, 6th ed. West Sussex, UK : John Wiley & Sons Ltd., (2013).
80. S. M., & T. Z. Dawal, "The Effect of Job and Environmental Factors on Job Satisfaction in Automotive Industries," (2006).
81. A. B. Smith and C. D. Johnson, "The influence of environmental quality on tourist satisfaction: A case study of a coastal destination," *Tour Manag*, vol. 65, pp. 180–190, (2018).

82. R. Thompson, A. Davis, and S. Clark, “Exploring the influence of environmental quality on tourist satisfaction in national parks,” *Journal of Sustainable Tourism*, vol. 38, no. 2, pp. 211–225, (2020).
83. Y. S., & C. M. C. Chen, “The impact of tourist destination attractiveness on tourist satisfaction: A case study of a cultural destination,” *J Travel Res*, vol. 57, no. 5, pp. 645–659, (2019).
84. J. Kim and S. Lee, “Exploring the impact of destination attractiveness on tourist satisfaction in urban tourism,” *Tour Manag*, vol. 86, (2021).
85. Y. Liu and Y. Chen, “The effect of tourist destination accessibility on tourist satisfaction: A case study of rural tourism,” *Journal of Destination Marketing & Management*, vol. 17, (2020).
86. [86] H. Zhang and Y. Huang, “Exploring the effect of destination accessibility on tourist satisfaction: The case of an urban tourism destination,” *Tour Manag*, vol. 71, pp. 166–176, (2019).
87. H. Zhang, D. Wang, H. Song, and Z. Huang, “). The influence of tourist satisfaction on revisit intentions: The mediating role of destination image,” *Journal of Destination Marketing & Management*, vol. 16, (2020).