

Analysis of promising areas of constructive and technological improvement of units for digging seedlings

Vladimir I. Konovalov* and Alexey G. Konovalov

Kuban State Agrarian University named after I.T.Trubilin, 350044, Krasnodar, Russia

Abstract. The ways to improve the technological process aimed at the digging of various plant species consists of various successive stages. Among them, we can single out the stage of analysis of already existing structural and technological solutions. The article presents an analysis of the directions of development of digging units. The source of information was the open registers of the FIPS of the Russian Federation and foreign databases. During the analysis, the main ways of improving the technological process of digging seedlings and technical solutions for its implementation, as well as ways to achieve a blocked technical result, were identified. Based on the data obtained, a design and technological scheme of the digging bracket has been developed. Further ways of improving the proposed technical solution are outlined.

Relevance of the study

The process of developing new units is very complex and long and includes a list of stages that are interconnected. These include an analysis of the current state and directions of development of gardening mechanization tools, the formation of initial requirements for a specific operation and the construction of an experimental sample, the testing with subsequent refinement to improve the results [22]. However, already at the initial stage, having performed a deep and comprehensive analysis of serial and promising design and technological schemes, it is possible to significantly narrow down the range of necessary scientific and technical tasks, thus determining the most promising direction for improving the required technological process [16, 17, 21, 25].

Problem statement

Currently, the most complex technological process in the cultivation of seedlings, seedlings of fruit and ornamental crops, ornamental and berry bushes, as well as rose bushes is their digging out. The main agrotechnical task when digging trees, shrubs and seedlings is that in the process of their separation from the soil monolith, the root system, trunk and branches of the plant should be without damage, since in the future, when moving to a new place,

* Corresponding author: konovalov.v.i@mail.ru

this will allow them to grow faster and adapt to a new place. The seedlings are dug out with a special bracket, which is buried to a depth of 25-35 cm, cuts and lifts the soil layer together with the root without turning the layer. To solve this problem, various design and technological schemes have been developed that allow solving this problem.

There are various structural and technological schemes for digging, which have both simple structures that have a passive cutting part that cuts the soil layer with the plant root, and a vibration mechanism that increases the degree of crumbling of soil lumps, and thereby increases the efficiency of the root digging process from the soil.

Presentation of the main research material

In the process of analyzing the directions of development of mechanization tools for digging seeds, ornamental and fruit trees, ornamental and berry bushes and rose bushes, the data of open registers of the Federal Institute of Industrial Property of the Russian Federation and foreign databases of patent documents were systematized. Despite the wide variety of different approaches to achieve the required technical result, all the considered technical solutions have common features and approaches [18, 19].

In an agricultural unit according to RF patent 2172576, designed for digging seedlings (Fig. 1), consisting of a supporting frame 1 with a trailer device 2, support wheels 3 are installed in front, which allow the frame to be aligned in a horizontal plane, and rear support wheels 4 are installed, through which the depth of digging out is regulated [2]. As working bodies, horizontal lancet knives with a cutting angle of 45° 5 are used, which are attached to racks 7, vertical knives 9, staggered in mounting brackets 8 on longitudinal bars 6 and a movable chest 10, pivotally fixed to horizontal knives 5. In addition, the agricultural unit is equipped with a loosening sieve 12 with a device 11 for changes in its angle.

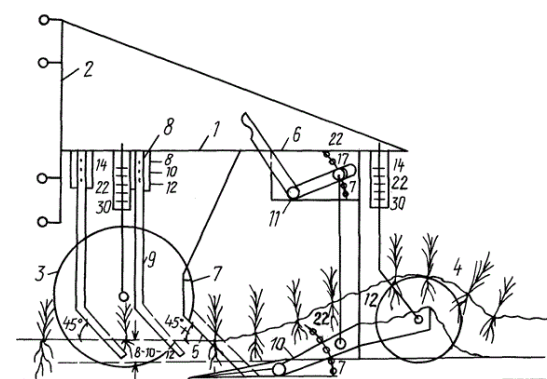

1 – frame; 2 – trailer device; 3 – front wheel; 4 – rear support wheel; 5 – horizontal pointed knife; 6 – longitudinal beam; 7 – side rack; 8 – mounting bracket; 9 – vertical knife; 10 – movable chest; 11 – fixture; 12 – loosening sieve

Fig. 1. Diagram of a unit for digging seedlings under the RF patent 2172576 [2].

When working, the agricultural unit is driven to the required depth and begins to move, while vertical knives 9 cut off the soil layer on the sides, cutting off the lateral roots, and horizontal lancet knives 5, cut the horizontal soil layer together with the vertical root, thereby a single layer of soil with a seedling enters the movable chest 10, where loosening occurs soil. As a result of the work, thanks to the horizontal lancet knives 5 installed at an angle of 45° , the soil layer with the roots of the plant is completely cut, thereby improving the quality of digging out the planting material.

In the unit for digging seedlings according to the RF patent 198468 (Fig. 2), it is proposed to use a disk digger 7, which is equipped with cutting knives 8 with a drive 9, which provides rotation of the disk from top to bottom when cutting it into the soil, an additional frame 10 to which a disk digger and a digging knife are attached, a longitudinal thrust 11, and a controlled hydraulic cylinder 12 of the parallelogram mechanism [3].

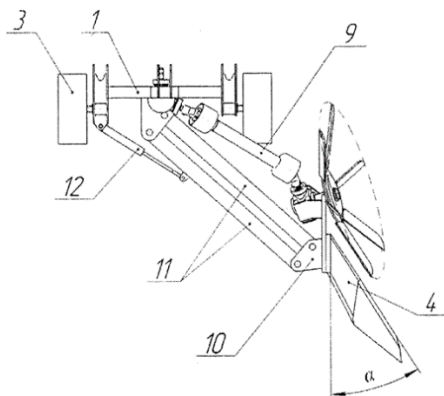

1 – frame; 2 – suspension mechanism; 3 – wheel; 4 – digging knife; 5 – stand; 6 – blade; 7 – disc digger; 8 – cutting knife; 9 – drive; 10 – additional frame; 11 – longitudinal thrust; 12 – hydraulic cylinder

Fig. 2. Diagram of a unit for digging seedlings under the RF patent 198468 [3].

When the unit is operating, the drive 9 is connected to the tractor PTO using a cardan shaft, then the drive 9 rotates the disk digger 7, which in turn digs up seedlings and effectively loosens the soil in the area where the roots of the digged seedlings are located in the soil. As a result of the rotation of the disc digger 7, the knives 8 cut into the soil from top to bottom, thereby cutting off and loosening the soil in the area of the seedlings being excavated. The blade 6 of the digging knife 4 cuts the remaining rod roots lying at the depth of the excavation. As a result of the work of the disk digger 7 paired with the blade 6 of the digging knife 4, the roots of the excavated plant remain with minimal damage, which leads to an improvement in the quality of the planting material.

A design and technological scheme of the digging unit has been developed (Fig. 3), which assumes the use of three vertical pointed knives 12 [4] to improve the quality of digging planting material.

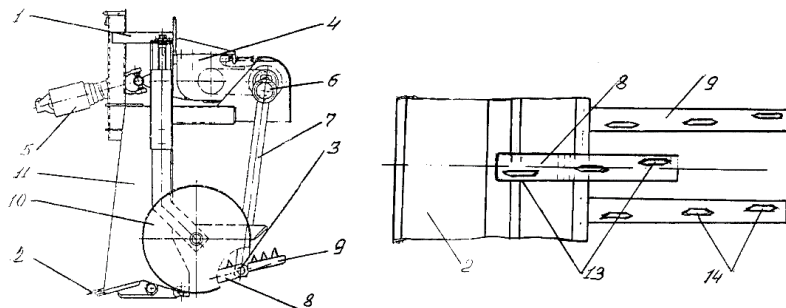

1 – frame; 2 – digging bracket; 3 – shaft; 4 – gearbox; 5 – cardan shaft; 6 – crank; 7 – connecting rod; 8 – extension rod; 9 – bar; 10 – support wheel; 11 – side knife-rack; 12 – pointed knife; 13 – knife

Fig. 3. A digging unit for forest nurseries under the RF patent 191875 [4].

During the operation of the unit, due to the use of three vertical pointed knives 12, installed in extensions and slats, and located with the displacement of each subsequent knife relative to the previous one to the side, plant roots are cut off, followed by the separation of the soil layer into shelves, which eliminates root breakage and ensures careful cutting of the root system due to loosening of the soil layer into different fraction, ensuring the preservation of roots, thereby improving the quality of planting material.

Employees of Voronezh State Forestry Academy propose to use a machine for digging seedlings (Fig. 4), which includes working bodies made in the form of triangles 4, while for smooth entry into the soil they have a direction with sharp angles towards the excavated seedling [5]. To increase the expansion of functionality and improve the quality of work, the machine is equipped with a half bucket 5, a hydraulic cylinder 6 and a limiter 9.

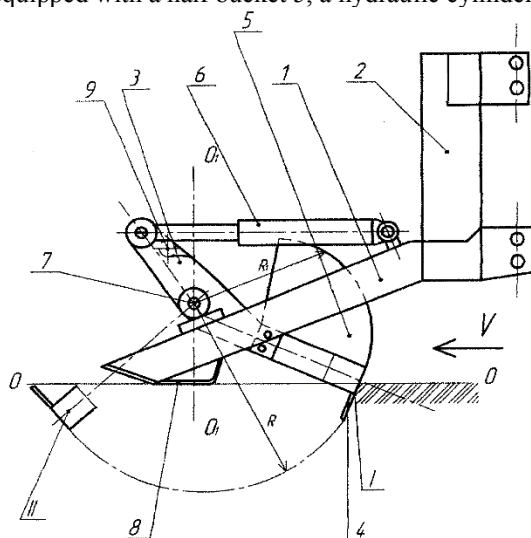

1 – frame; 2 – attachment; 3 – rack; 4 – triangle; 5 – half-bucket; 6 - hydraulic cylinder; 7 – hinge; 8 – mounting of vertical racks; 9 – limiter

Fig. 4. Scheme of the digging machine according to RF patent 99277 [5].

During the operation of the proposed digging unit according to RF patent 99277, due to a smoother entry into the soil, the root system of the seedling is cut without damaging them, thereby improving the quality of the planting material.

In the technological scheme of the digging unit, G. V. Beshnov suggests using wedge-shaped rippers of different heights mounted on a pruning knife [6]. When transmitting vibrations to the rippers, direct cutting of the soil layer is combined with sliding cutting and activation of the loosening process. When digging, an even cut of the root system of the seedling occurs.

In the considered machines for digging seedlings, it is proposed to improve the quality of digging by oriented installation of horizontal, vertical pointed or triangular blades, wedge-shaped rippers, as well as using an additional disk working body.

In addition to the quality of planting material digging, the reliability of the tool used is of no small importance, since this will inevitably lead to a decrease in productivity, as well as to the inability to work with stable technological adjustments, leading to a decrease in the quality of the resulting product [20].

To eliminate this drawback, the digging bracket according to the RF patent 203564 (Fig. 5) consisting of a frame 1, a suspension mechanism 2, a support wheel 3, a digging bracket 4 with a ploughshare 5 and installed extensions 6, is equipped with a crank mechanism to

give vibration vibrations to the extensions [7]. The drive is carried out through a crank 7, a connecting rod 8, which is bent by a section 9, by means of brackets attached to extension cords 6.

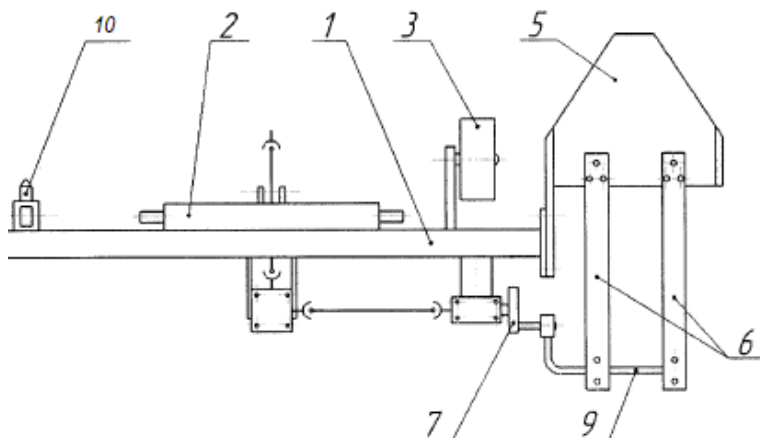

1 – frame; 2 – suspension mechanism; 3 – support wheel; 4 – bracket; 5 – ploughshare; 6 – extension; 7 – crank; 8 – connecting rod; 9 – bent section; 10 – stability knife

Fig. 5. Scheme of the digging bracket according to RF patent 203564 [7].

Due to the rigid connection of the connecting rod of the crank mechanism with elastic extensions in their rear part, the reliability of the structure increases and intensive wear of its moving parts is eliminated.

In the digging unit proposed by Kazakov V. I. for forest nurseries, it is recommended to install horizontal hinges at the junction of the extension cords on the base plate, which increases the reliability of the vibration shaker assembly [8].

From the considered structural and technological schemes of machines for digging wells, it can be concluded that the increase in the reliability of the unit is supposed to be obtained by using flexible or movable structural elements, the attachment of which to the main parts is rigid, which allows additional degrees of freedom of the working bodies.

In addition to improving the quality of operations performed and the coefficient of technical reliability of the technical means used, more and more attention is paid to their annual load, since this, through depreciation and other deductions, has a significant impact on the final cost of production [1, 15].

To expand the functionality in the digging unit according to the RF 2239975, which includes a frame, a hinged device, support wheels and a pruning bracket, angular displacement limiters are installed on the frame, limiting the movement of the bracket from the horizontal at an angle from 1 to 25 °. When digging plants, the bracket is installed at a large angle to the horizon to ensure loosening of the soil layer with plants, and when performing the function of a root cutter, i.e. pruning roots, the angle is set to practically zero, which leads to a decrease in soil loosening [9]. Thus, due to the installation of angular displacement limiters, the unit can be used in two different operations.

The design scheme proposed by American inventors under patent 4067268 is intended for both digging up plants and planting them [13]. This scheme includes a transport lever 1, a vehicle 2, a shaft 3, a hydraulic cylinder 4, a tubular tool 5, a digging tool 6, a return plug 7.

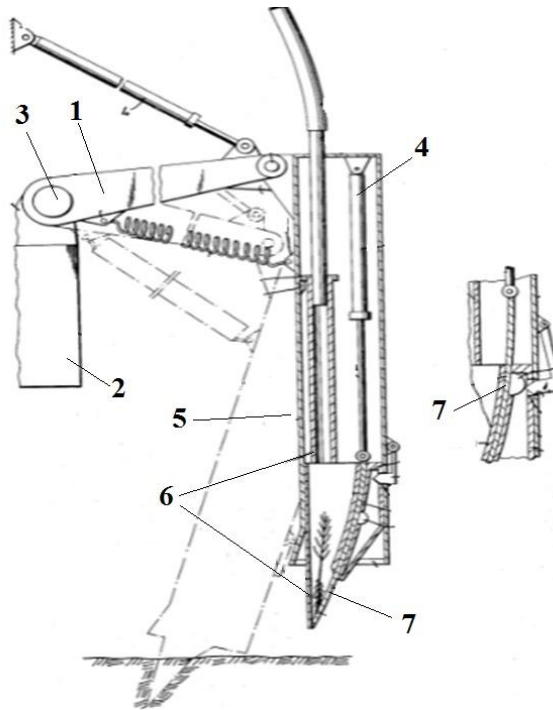

1 – transport lever; 2 – vehicle; 3 – shaft; 4 – hydraulic cylinder; 5 – tubular tool; 6 – digging tool; 7 – return plug

Fig. 6. The scheme of the digging and planting unit according to the patent 4067268 [13].

When the unit is operating, the driver activates the hydraulic cylinder 4, which in turn moves a lever 1, a tube 5, a digging tip 6 down to the ground. The digging tip 6 is embedded in the ground and when the specified depth is reached, the hydraulic cylinder 4 is released. After that, the driver moves the piston up, removing the flap and opening the hole. Then the plant falls into the dug hole. After the sealing ring presses the soil and the plant remains in the ground. When digging up a plant, the hydraulic cylinder moves the digging tip down, thereby pruning the roots of the plant and lifting it up. After that, the driver can transport the seedling to the planting pit.

The sapling digging unit proposed by Korean inventors is designed for digging plants with a lump, as well as for preparing planting pits, and includes the main frame 1, the first 2 and second 3 blades, a fixed shaft 4, a blade cylinder 5, a tree holder 6 and a guide 7 [14].

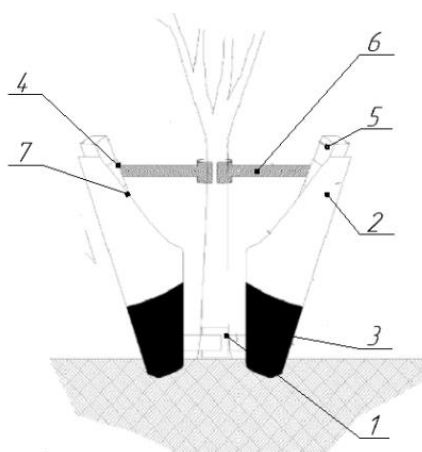

1 – main frame, 2 – first blade, 3 – second blade, 4 – fixed shaft, 5 – blade cylinder, 6 – tree holder, 7 – guide

Fig.7. Diagram of the unit for digging and transporting trees according to the patent 1020160144776 [14].

When the unit is operating, the operator drives up to the selected plant, then fixes the seedling with the help of a tree holder, after which he activates the blade cylinder, which, in turn, moves the first and second blades of the unit down along the guide. When cutting the blades into the ground, they prune the roots of the plant along with a soil clod. After the operator lifts the plant up with the help of a hydraulic cylinder and transplants it to another place.

Thus, to expand the functionality of digging units, it is proposed to use them for pruning the roots of seedlings and for digging holes when planting them.

Also of no small importance is the energy intensity of the process, which directly determines the cost of fuel and lubricants [1, 23]. In the unit for digging seedlings (Fig. 2), to reduce the traction resistance of the digging working body, it is proposed to use a bent stand of the digging knife located in the alignment with a disk digger, which provides a reduction in resistance during digging.

In the digging unit according to the RF patent 99277, on working bodies made in the form of disk diggers, it is proposed to use disks mounted at an angle to the surface, as well as equipped with knives that make up sharp angles with the disk plane and deviated inward from it [9]. Such a constructive solution allows when the disks are embedded in the soil, to rotate them from top to bottom, providing loosening of the soil and reducing traction resistance. In addition to these design and technological solutions, it is proposed to use various combinations of working bodies and alternating harmonic oscillations, which will also contribute to reducing traction resistance.

Thus, to reduce the traction resistance, it is proposed to use vibrating or working bodies installed at an angle less than the friction angle.

The reliability and market price of digging machines depends not only on the reliability of the assembly units and parts themselves, but on their number, therefore, simplification of structural and technological schemes is also a promising direction for their improvement [1]. For example, for forest nurseries under the RF Patent 95218 (Fig. 8) in a unit, it is proposed to use a simple design that includes a frame 1, a suspension mechanism 2, a working body 3 and skis 4 [11].

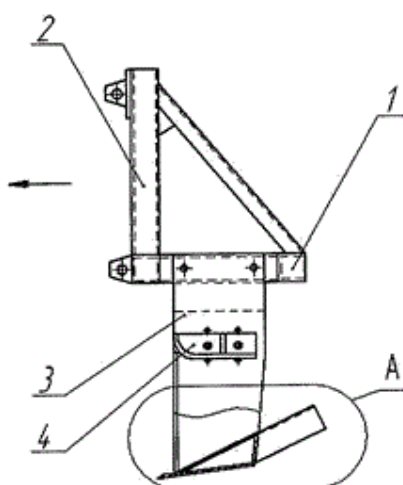

1 – frame; 2 – suspension mechanism; 3 – working body; 4 – skis

Fig. 8. The scheme of the digging bracket for forest nurseries according to the RF patent 95218 [11].

This unit has a minimal number of parts compared to the above-mentioned digging units, while all the parts of the working body are connected to each other in the places of attachment by welding, forming a rigid dihedral wedge. According to the same principle, a design and technological scheme was formed according to the RF patent 95217 [12]. In addition, in the previously described digging bracket under the RF patent 203564 (Fig. 5) it is supposed to use a minimal number of parts equipped with a vibration mechanism, in which the rigid connection of the crank mechanism with elastic extensions simplifies the design [7].

Due to the asymmetry of the location of the working bodies relative to the traction line of the power equipment, additional requirements for course stability arise during the operation of digging units [20, 24]. For example, for digging seedlings according to the RF patent 198468 (Fig. 2), due to the disk digger, a reactive force is created that balances the resistance force from the side of the digging knife, thereby stabilizing the equilibrium of the unit in the horizontal plane, which increases the exchange rate stability in a unit [3]. According to the same principle, it is proposed to increase the exchange rate stability in the design and technological scheme of Drapalyuk M.V., which involves the installation of knives on disks at an angle to stabilize the cutting moments [10]. In the root pruner for forest nurseries according to the RF Patent 95217, the displacement of the unit in the horizontal plane is achieved through the use of runners and flat paws, which allow maintaining the required digging depth, thereby reducing the magnitude and probability of multidirectional moments [12]. In other words, it is proposed to increase the exchange rate stability of promising digging units by using various combinations of support and cutting elements with a clear orientation in space.

Approbation of the results obtained

Based on the analysis of various technical solutions, a design and technological scheme of the digging bracket has been developed (Fig. 9), which includes a frame 2, a suspension mechanism 5, a digging knife 1, a stability knife 3, mounted with an offset relative to the axis of the frame, swept knives 6, which are mounted on the digging knife in front, strigels 4, which are installed behind the knife and the pneumatic vibrator 7.

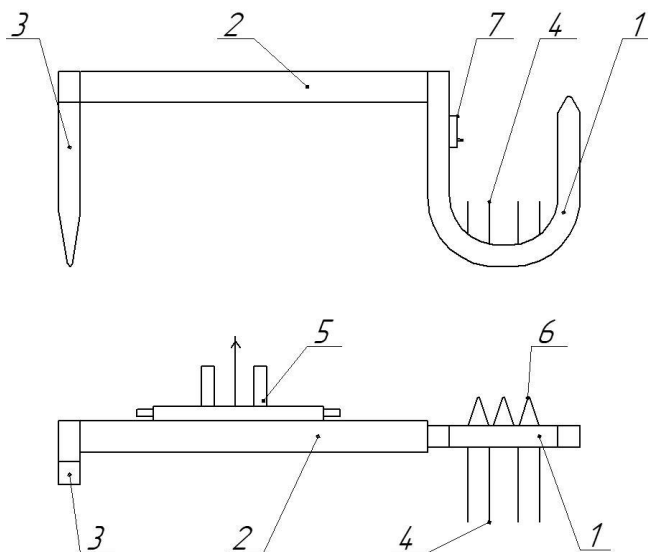

1 – digging knife; 2 – frame; 3 – stability knife; 4 – strigels; 5 – attachment mechanism; 6 – arrow-shaped knife; 7 – pneumatic vibrator

Fig. 9. The design and technological scheme of the developed digging bracket:

When working with the proposed digging bracket, the arrow-shaped knives will ensure smooth cutting of the root system of the plant due to their shape. In turn, the stability knife will increase the exchange rate stability in the horizontal plane. Installation of pcs of cross-bars to improve the quality of loosening of the soil layer. The pneumatic vibrator will apply alternating loads to the digging knife and strigels, which will reduce the traction resistance of the working body and improve the quality of soil loosening. All parts in the places of fit are rigidly connected to each other, which will increase the reliability of the structure.

Conclusion

The obtained research results allow us forming the main directions of the development of the means of mechanization of the seedlings digging, which, according to the technical result, can be divided into the following types:

- improving the quality of the digging of planting material;
- improving the reliability of the structure;
- expansion of functionality;
- reduction of the traction resistance of the digging working body;
- simplification of the design;
- increase of exchange rate stability.

Having analyzed various constructive and technological solutions for improving the process of digging seedlings, it can be concluded that the most attention is paid to improving the quality of digging. At the same time, in order to improve the quality of planting material digging, it is necessary that during digging the working body of the bracket smoothly cut the root system of the plant, and from all the technical solutions considered, the following main ways to improve the quality of planting material during digging can be distinguished:

- installation of a transverse knife at a certain angle to the horizon;
- installation of vertical knives with offset;
- installing a disk digger;

– creation of vibration on working organs.

To improve the quality of high-strength material, reduce the energy intensity of the technological process, simplify the design and increase the exchange rate stability of the unit, a constructive and technological scheme of the digging bracket is proposed. At the next stage it is necessary to supplement it with elements that allow expanding its functionality to increase the economic efficiency of the operation of the proposed design and technological scheme.

References

1. Kastidi Yu.K. The economic efficiency of the provision of commodity producers of Krasnodar territory with agricultural machinery [Text] / Yu. K. Kastidi, D. A. Krepushev // Proceedings of Kuban State Agrarian University – Krasnodar.: PH "KubSAU". – 2011. No. 28. pp. 39-42.
2. Pat. 2172576RF, IPC A01B 39/12, A01B39/00, A01B 39/02, A01G 23/00. Digging bracket [Text] / A. P. Shadrin; applicant and patent holder A. P. Shadrin. - No. 2000111710/13; application. 12.05.2000; publ. 27.08.2001 Bulletin No. 24.
3. Pat. 198468 RF, IPC A01D 13/00. Machine for digging seedlings [Text] / V. G. Brosalin, A. A. Zavrazhnov, A. I. Zavrazhnov, A. A. Zemlyanoi, V. Yu. Lantsev; applicant and patent holder Federal State Budgetary Scientific Institution "Federal Scientific Center named after I.V. Michurin". - No. 2020112601; application No. 25.03.2020; publ. 13.07.2020 Byul. No. 20
4. Pat. 191875 of the Russian Federation, IPC A01C 11/04. Digging machine for forest pets [Text] / A. A. Martynyuk, V. I. Kazakov, V. T. Degtev, N. E. Prokazin, I.V. Kazakov, E.N. Lobanova; applicant and patent holder Federal Budgetary Institution "All-Russian Research Institute forestry and Forestry Mechanization (FBU VNIILM)". - No.2019103759; application No. 11.02.2019 publ. 26.08.2019 Bulletin No. 24
5. Pat. 99277 RF, IPC A01C 11/00. Digging machine [Text] / M. V. Drapalyuk, D. Y. Druchinin; applicant and patent holder State Educational Institution of Higher Professional Education "Voronezh State Forestry Academy". - No. 2010111038/12; application 23.03.2010; publ. 20.11.2010 Bulletin No. 32
6. Pat. 93030476 RF, IPC A01C 11/00. Digging machine [Text] / G. V. Beshanov, V. V. Ilyukhin; applicant and patent holder of the All-Russian Breeding and Technological Institute of Horticulture and Nursery. - No. 93030476/15; application 16.06.1993 published 20.02.1997
7. Pat. 203564 RF, IPC A01C 11/04. Machine for digging seedlings [Text] / V. G. Brosalin, A. S. Goncharov, A. A. Zavrazhnov, A. I. Zavrazhnov, A. A. Zemlyanoi, V. Yu. Lantsev; applicant and patent holder Federal State Budgetary educational Institution of Higher Education "Michurinsky State Agrarian University". - No. 2020137222; application 11.20; publ 12.04.2021 Bulletin No. 11
8. Pat. 61982 RF, IPC A01C 11/04. Digging machine for forest nurseries [Text] / V.I. Kazakov, S. A. Rodin, V.T. Degtev, I.V. Kazakov, E.N. Lobanova; applicant and patent holder of the Federal State University All-Russian Scientific Research Institute of Forestry and Forestry Mechanization (VNIILM). - No. 2006145727/22; application No. 25.12.2006; publ. 27.03.2007 Bulletin No. 9
9. Pat. 2239975 RF, IPC A01C 11/00. Kornepodrezchik [Text] / V. I. Kazakov, O. G. Klimov; applicant and patent holder All-Russian Scientific Research Institute of Forestry and Forestry Mechanization (VNIILM). - No.: 2002112470/12; application 15.05.2002; publ. 20.11.2004 Bulletin No. 32

10. Pat. 99277 RF, IPC A01C 11/00. Digging machine [Text] / M. V. Drapalyuk, D. Y. Druchinin; applicant and patent holder State Educational Institution of Higher Professional Education "Voronezh State Forestry Academy". - No.2010111038/12; application 23.03.2010; publ. 20.11.2010 Bulletin No.32
11. Pat. 95218 RF, IPC A01C 11/00. Digging bracket for forest nurseries [Text] / A. A. Golovin, A. E. Vishnev, A. A. Golovin; applicant and patent holder Limited Liability Company Creative Innovation Enterprise "Innovator". - No.2010111074/22; application 23.03.2010; publ. 27.06.2010 Bulletin No.18
12. Pat. 95217 RF, IPC A01C 11/00. Root pruner for forest nurseries [Text] / A. A. Golovin, S. M. Vasiliev, A. A. Golovin; applicant and patent holder Limited Liability Company Creative Innovation Enterprise "Innovator". - No.2010111071/22; application 23.03.2010; publ. 27.06.2010 Bulletin No.18
13. Pat. 4067268 USA, IPC A01G 23/00, A01G 23/04, A01C 11/00. Digging and planting machine [Text] / Lofgren Stig-Gunnar
14. Ekeborg Bo Gunnar; applicant and patent holder Mooch Domsjo Aktiebolag. - No. 05680270; application. 04/26/1976 publ. 01.10.1978.
15. Pat. 1020160144776 Republic of Korea, IPC A01G 23/04, A01C 11/04, A01G 23/02. APPARATUS FOR TRANSPLANTING TREE [Text] / 조의환; the applicant and the patent holder 조의환. - No. 1020150081359; application 09.06.2015 publ. 19.12.2016.
16. Sokolova A. P. The influence of equipment availability on economic parameters of crop production [Text] / A. P. Sokolova, Yu. K. Kastidi, G. F. Bershetskaya G.F., M. E. Trubilin // Rural mechanizer – M.: Iz-vo. "Niva". - 2015. No. 2. pp. 22-23.
17. Konovalov V. Constructive-technological diagram of the rotary-string cultivator and the definition of its main parameters / V. Konovalov, S. Konovalov, V. Igumnova // E3S Web of Conferences 126, 00039 (2019)
18. Konovalov V. Analysis of the directions of the development of mechanization units for processing the neartrunk area in the garden / V. Konovalov, S. Konovalov // E3S Web of Conferences, 2020, 193, 01013
19. Konovalov V. Analytical study of the design parameters of the grinding unit of disk harrows / V. Konovalov, S. Konovalov, V. Igumnova // IOP Conference Series: Earth and Environmental Science. – 403 (2019) 012086
20. Konovalov V. Justification of design parameters of a disk working body with a changing radius of curvature / V. Konovalov // E3S Web of Conferences, 2020, 193, 01014
21. Trubilin E.I. Experimental studies of parameters of pneumatic slot sprayer / Trubilin E.I., Borisova S.M., Konovalov V.I., Chebotarev M.I., Gumbarov A.D. // International journal of emerging trends in engineering research. – 2020. – Vol. 8 №1 DOI: 10.30534/ijeter/2020/23812020.
22. Konovalov V. Tillage And Creation Of Soil Structure In The Conditions Of Krasnodar Territory / V. Konovalov // AIP Conference Proceedings 2503, 030009 (2022); <https://doi.org/10.1063/5.0105395>
23. Konovalov V. Analysis Of Development Trends Of Disk Tillage Organs For Increasing The Degree Of Soil Crumbling / Konovalov, V., Konovalov, S., Baradakov, V. // AIP Conference Proceedings 2503, 030008 (2022); <https://doi.org/10.1063/5.0104948>
24. Konovalov V. Analysis of research on soil destruction criteria during its interaction with working bodies / V. Konovalov // E3S Web of Conferences 285, 07003 (2021) ABR 2021 doi.org/10.1051/e3sconf/202128507003

25. Serguntsov, A. Theoretical research of needle-shaped harrow operation expended on soil pinching by needles / A.Serguntsov, V. Serguntsova // E3S Web of Conferences. – 2019. – Vol. 126. – P. 00024.
26. Serguntsov, A. Operational parameters and modes of rotary working body for harrowing crops / A.Serguntsov, V. Serguntsova, N.Malashikhin // E3S Web of Conferences. – 2019. – Vol. 126. – P. 00023.