

Studying the movement of fertilizers in the fertilizer spreader

S Temirov¹, M Tukhtabayev^{1*}, and Z Turgunov¹

¹Namangan Engineering Construction Institute, Islam Karimov avenue-12, Namangan, 160103, Uzbekistan

Abstract. The article presents the results of the study to substantiate the angle of the vertical installation of the fertilizer spreader, which localizes the fertilizer between the rows of cotton. Based on the results obtained, a working body is developed for mixing organic and mineral fertilizers during intercropping. The movement of the fertilizer pieces along the X and Y axes was studied. The coordinates of the fertilizer pieces' landing point on the working surface of the fertilizer spreader, their velocities, and motion equations of the fertilizer pieces in the next jump were created. As a result, the cotton grows equally and yields a good harvest. The movement of the fertilizer pieces and the movement and distribution of the fertilizer spreader along the working surface are studied. It was found that the vertical mounting angle of the fertilizer could be $\varepsilon = 18^\circ$.

Keywords: fertilizer spreader, cotton, cultivator, organic fertilizer, organic fertilizer, cotton-row, feeder, furrow.

1 Introduction

During growing, when mineral fertilizers are completely decomposed and then mixed with dried manure, the yield increases by 2–3 centners per hectare. It is recommended to use 2–2.5 t of rotten manure per ton of ammonium nitrate [1,2]. Such fertilizers are applied between rows of cotton 2–3 times with cultivator-feeders, considering the biological characteristics of cotton growth and growth phases [3,4]. However, the existing cultivators cannot supply that the fertilizers are applied in accordance with the agro-technical requirements. The fertilizers are only applied to depths of 8–10 cm, as a result, it is difficult for fertilizers to reach the plant roots. Besides, the use of existing colters in fertilizing of organic and mineral fertilizers leads to the disruption of the technological process due to their clogging [5,6,7].

Based on the above, a working body is developed to mix organic-mineral fertilizers in the inter-row cultivation of cotton [7,8]. It consists of column 1, ripper 2, fertilizer feeding tube 3, and fertilizer spreader 4 (Figure 1). Its technological process is as follows: the fertilizers coming from through the feeding tube 3, go to the fertilizer spreader 4 and then fall to the bottom of the furrow where the ripper of the working body is opened [9,10,11].

*Corresponding author: mirzoxidt_2011@mail.ru

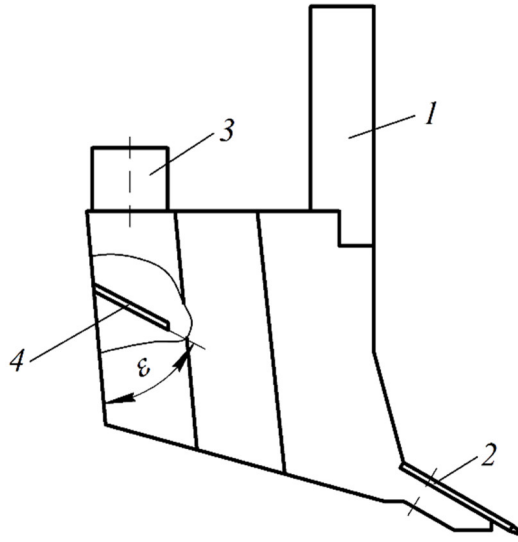

Fig. 1. The working organ spreads organic-mineral fertilizers between rows of cotton.

2 Materials and methods

Cultivators between cotton rows are widely used in practice [12,13]. The cultivator-fertilizer is designed to remove weeds, loosen the soil, open irrigation furrows, and fertilize a mixture of organic and mineral fertilizers between rows with widths of 60 and 90 cm [14,15,16]. Depending on the type of work to be performed, these cultivators are equipped with rotating sprockets, flat cutting blades, ripper and axial flat cutting claws, and other working bodies. A flat-cutting knife is used to cut the roots of weeds and loosen the soil to a depth of 6-8 cm [17,18,19]. Different devices have been used at different times to improve soil reclamation and fertilize plants [20,21,22,23].

Fertilizers coming from fertilizer feeding tube 3 to the fertilizer spreader 4 may move by jumping or slipping on its surface relating to their physic-mechanical properties, as well as the vertical position of the fertilizer spreader depending on the mounting angle. The former case is observed when the installation angle of the fertilizer spreader relative to the vertical and the recovery coefficient of fertilizers are large, and the latter case is observed when they are small.

As the fertilizer jumps along the fertilizer spreader, the piece of fertilizer that falls on it with velocity V_b turns back at α angle from it and moves freely at velocity V_0 (Figure 2).

According to the theory of impact [3]

$$tg\alpha_i = \frac{tg\alpha_{fall}}{K_T}; \tag{1}$$

$$V_0 = V_b \sqrt{\sin^2 \alpha_{fall} + K_T^2 \cos \alpha_{fall}}, \tag{2}$$

where α_{fall} – the angle at which the piece of fertilizer enters the fertilizer spreader, degrees;
 K_T – the recovery rate of the fertilizer.

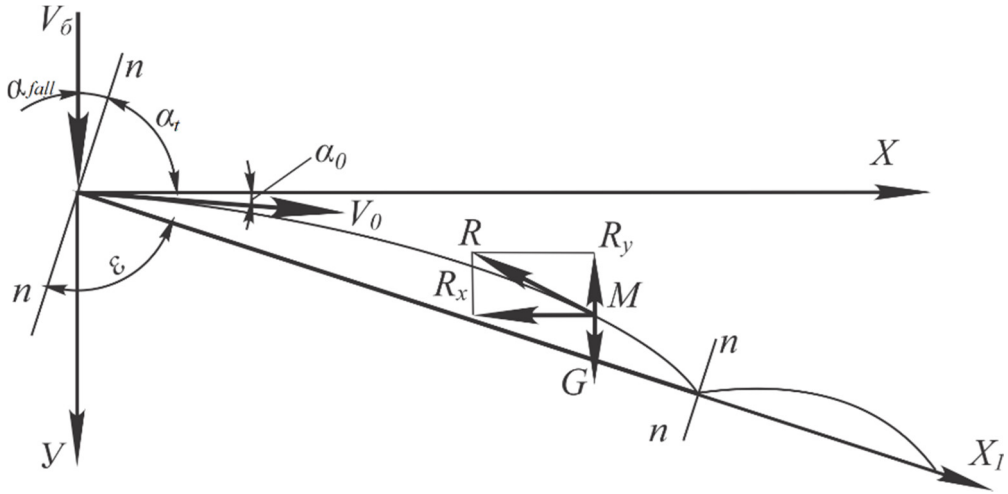

Fig. 2. Study scheme of the fertilizer piece movement with a jump in the fertilizer spreader.

3 Results and discussion

In the present section, a novel formulation is derived, which enables the estimation of the angle of the vertical installation of the fertilizer spreader.

The weight $G = mg$ (m – a mass of fertilizer piece, kg; g – acceleration of free fall, m/s^2) and air resistance R forces influence the piece of the fertilizer moving freely in the air, returning with V_0 velocity from fertilizer spreader. We will study the movement of the fertilizer piece under influence of these forces. To do this, we construct differential equations of its movement along the X and U axes.

$$m \frac{dV_x}{dt} = -R_x ; \tag{3}$$

$$m \frac{dV_y}{dt} = G - R_y, \tag{4}$$

where V_x, V_u – projections of the fertilizer pieces' velocity returning from the fertilizer spreader on the

X and Y coordinate axes, m/s;

t – the time, s;

R_x, R_u – the components of the air resistance R along the X and Y coordinate axes, N.

Assume that the air resistance is proportional to the first level of velocity [3], ie $R = mkV_0$ (where k – the coefficient of proportionality; V_0 – the velocity of the fertilizer pieces in free movement, m/s). Given that this and also $G = mg$, equations (3) and (4) have the following form:

$$\frac{dV_x}{dt} = -kV_x \tag{5}$$

and

$$\frac{dV_y}{dt} = g - kV_y \tag{6}$$

Integrating these equations at $t = 0$, considering the conditions $V_x = V_0 \cos \alpha_0$ and $V_y = V_0 \sin \alpha_0$ (where α_0 – the angle between the V_0 and the OX axis of the return velocity of the fertilizer piece), we obtain the following equations.

$$V_x = V_0 e^{-kt} \cos \alpha_0 \tag{7}$$

and

$$V_y = \frac{g(e^{-kt} - 1) + kV_0 \sin \alpha_0}{ke^{kt}}. \tag{8}$$

From these expressions we obtain the following:

$$\frac{dX}{dt} = V_0 e^{-kt} \cos \alpha_0 \tag{9}$$

and

$$\frac{dY}{dt} = \frac{g(e^{-kt} - 1) + kV_0 \sin \alpha_0}{ke^{kt}} \tag{10}$$

Integrate equations (9) and (10) according to the conditions $X = 0$ and $Y = 0$ at $t = 0$, and we get equations that represent the movement of the fertilizer piece after its return from the fertilizer spreader.

$$X = \frac{1}{k} V_0 (1 - e^{-kt}) \cos \alpha_0 \tag{11}$$

and

$$Y = \frac{1}{k} [gt - (\frac{g}{k} - V_0 \sin \alpha_0)(1 - e^{-kt})]. \tag{12}$$

Based on the scheme shown in Figure 2 and expression (1)

$$\alpha_{fall} = 90^\circ - \varepsilon; \tag{13}$$

$$tg \alpha_t = \frac{ctg \varepsilon}{K_T} \tag{14}$$

Given expressions (2), (13) and (14), equations (11) and (12) can be written as

$$X = \frac{1}{k} V_b \sqrt{\cos^2 \varepsilon + K_T^2 \sin^2 \varepsilon} (1 - e^{-kt}) \cos(\arctg \frac{ctg \varepsilon}{K_T} - \varepsilon) \tag{15}$$

and

$$Y = \frac{1}{k} [gt - (\frac{g}{k} - V_b \sqrt{\cos^2 \varepsilon + K_T^2 \sin^2 \varepsilon} \sin(\arctg \frac{ctg \varepsilon}{K_T} - \varepsilon))(1 - e^{-kt})] \tag{16}$$

To solve these equations together, we get the following

$$Y = \frac{g}{k^2} \ln \frac{V_b \sqrt{\cos^2 \varepsilon + K_T^2 \sin^2 \varepsilon} \cos(\arctg \frac{ctg \varepsilon}{K_T} - \varepsilon)}{V_b \sqrt{\cos^2 \varepsilon + K_T^2 \sin^2 \varepsilon} \cos(\arctg \frac{ctg \varepsilon}{K_T} - \varepsilon) - kX}$$

$$\frac{g - kV_b \sqrt{\cos^2 \varepsilon + K_T^2 \sin^2 \varepsilon} \sin(\operatorname{arctg} \frac{\operatorname{ctg} \varepsilon}{K_T} - \varepsilon)}{kV_b \sqrt{\cos^2 \varepsilon + K_T^2 \sin^2 \varepsilon} \cos(\operatorname{arctg} \frac{\operatorname{ctg} \varepsilon}{K_T} - \varepsilon)} X. \tag{17}$$

(17) is the equation for trajectory of the first jump of fertilizer pieces after returning from spreader. Assuming $K_T = 0.3$, the trajectories of the first jump of the fertilizer pieces at different values of velocity V_b and angle ε are plotted in Figure 3. In Figure 3 the lines 1,2,3,4, respectively at $V_b = 1.5; 2.0; 2.5$ and 3.0 m/s; a, b, c – when $\varepsilon = 45^\circ, 60^\circ, 75^\circ$ respectively. It can be seen that with the increase in velocity V_b the angle of the fertilizer piece return from the fertilizer spreader, the height and length of the jump along it increases, and with the increase in angle ε the fertilizer pieces rotation angle and the height of the jump increased, while the length of the jump decreased.

To study subsequent jumps of the fertilizer pieces, it is necessary to determine the coordinates of the point where they meet again with spreader after first jump. We achieve this by solving equations $Y=Xctg\varepsilon$ and (17) together. It first determines coordinates of landing point of the fertilizer pieces on the working surface of the fertilizer spreader, and then their velocity. Then, in the above order, the equations of motion for the next jump of fertilizer pieces are constructed and solved.

It should be noted that when the fertilizer pieces jump on the working surface of the fertilizer spreader, they move erratically and intermittently, and as a result, they are not evenly distributed on the bottom of the furrow formed by the working body [4,5,7,8]. And this causes cotton to grow and harvest unequally.

As the fertilizer slides along the fertilizer spreader, the pieces of fertilizer that fall on it begin to slide along its working surface at an initial rate of $V_b \cos\varepsilon$.

Draw an X_1 axis along the working surface of the fertilizer spreader (Figure 2) and construct a differential equation for the fertilizer piece movement along this axis. It will look like this:

$$\frac{dV_{x_1}}{dt} = g(\cos \varepsilon - f \sin \varepsilon), \tag{18}$$

where f – friction coefficient of the fertilizer on the working surface of the fertilizer spreader.

When $t_1=0$, we have equation (18) and integrate it by conditions $V_{y_1} = V_\sigma \cos \varepsilon$ and $X_1 = 0$

$$V_{x_1} = V_b \cos \varepsilon + gt(\cos \varepsilon - f \sin \varepsilon) \tag{19}$$

and

$$X_1 = V_b t \cos \varepsilon + g \frac{t^2}{2} (\cos \varepsilon - f \sin \varepsilon) \tag{20}$$

It is clear from these expressions that fertilisers have to slide on the surface of fertiliser spreader in order to supply that fertilisers are spread equally to the bottom of the field formed by working body in the direction of the movement.

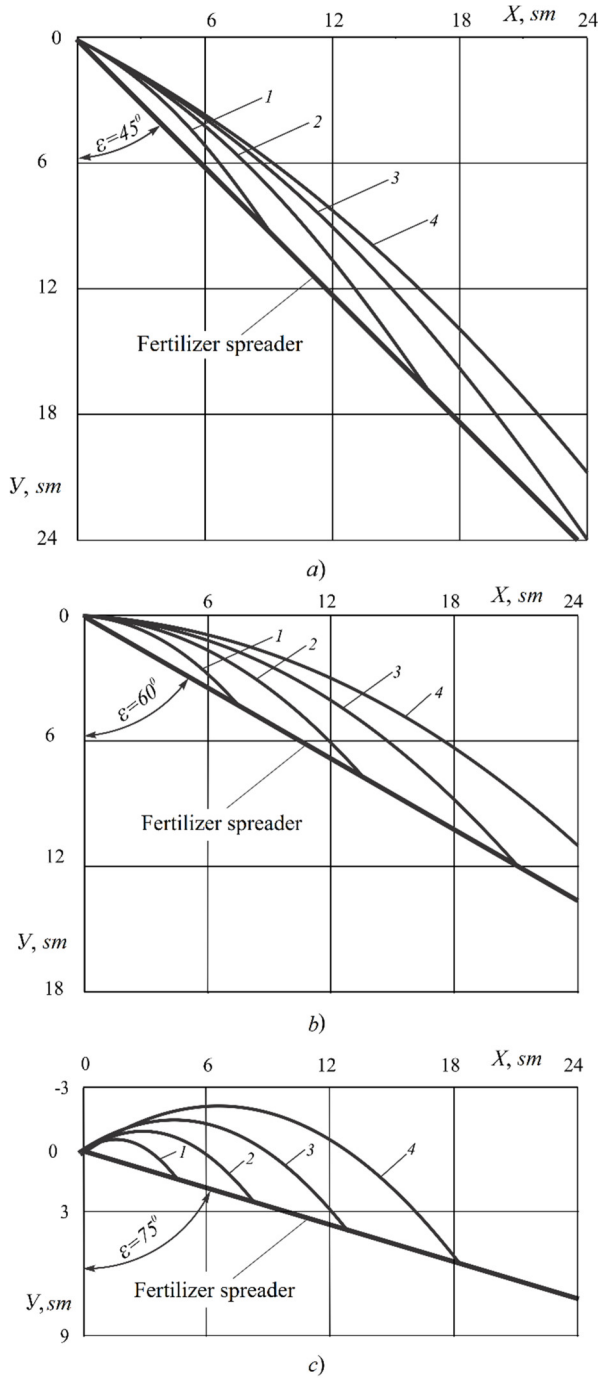

Fig. 3. Jump trajectories of fertilizer pieces at different values of velocity V_b and angle ε .

4 Conclusions

The main outcome of this study is the derivation of the equations (19) and (20). From the analysis of equations (19) and (20), it can be seen that when the fertilizer pieces slide on

working surface of the fertilizer spreader, their movement is orderly and continuous, and after it falls, the working body is evenly distributed on the bottom of furrow [4,5,7].

According to the research [4,5], the working parts of the fertilizer pieces move with a slide along the working surface of the fertilizer spreader, and its even distribution, i.e. mounting angle of the fertilizer spreader relative to the vertical can be no more than 18°.

Based on the research, the parameters that ensure the required quality of work of the working body that fertilizes cotton between the rows and the agro-technical indicators of the working bodies that fertilize were determined.

References

1. V. A. Sergienko, *Technological bases of mechanization of tillage in cotton aisles*, 112 (Fan, Tashkent, 1978)
2. Cotton guides, 500 (Mehnat, Tashkent, 1989)
3. T. R. Rashidov, Sh. Shoziyotov, Q. B. Muminov, *Fundamentals of theoretical mechanics*, 584 (Teacher, Tashkent 1990)
4. S. Khusainov, *Study of the technological process and parameters of the working body of a chisel fertilizer for incorporating fertilizers on saline lands (Yangiyul)*, 166 (1975)
5. Sh. A. Khamidov, *Justification of the parameters of the device to the subsoiler for deep broadband application of organomineral fertilizers in the cotton growing zone (Yangiyul)*, 166 (1985)
6. M. A. Tukhtabayev, *Applying for wide coverage four wheel machine-tractor aggregate in row-spacing*, Proc. Int. Conf. on Modern trends in the development of the agrarian complex, 1263-1266 (Solyonoye Zaymishe, FGBNU: PNIIAZ, 2016)
7. M. K. Shaikhov, *Application of high-speed spatial photography to study the movement of bulk materials*, 8-11 (NTB VIM, Moscow 1969)
8. S. U. Temirov, *Universal working body of a row cultivator*, Proc. Int. Conf. on Modern trends in the development of the agrarian complex, 1235–1237 (Salt Loan, FGBNU PNIIAZ, 2016)
9. A. Tukhtakuziev, S. Temirov, *Substantiation of coverage width of the combined body of the cotton cultivator*, **4**, 21-23 (Scientific and technical journal of Fergana Polytechnic Institute, Fergana, 2009)
10. S. Temirov, A. Nuriddinov, M. Tukhtabaev, *The Results of Determining of Working Depth Stability of the Universal Working Body and Width of Lateral Spread of Soil*, Int. J. Advanced Research in Science, Engineering and Technology (IJARSET), **8(5)**, (India, 2021)
11. S. U. Temirov, *Substantiation the Parameters of Universal Operating Element on Row Crop Cultivator*, Int. J. Advanced Research in Science, Engineering and Technology (IJARSET), **6(2)**, 8154-8156 (India, 2019)
12. T. M. Akhmadjanovich, *To select optimal tire sets for cultivator tractors*, European science review, **11-12**, 147-149 (2017)
13. M. A. Tukhtaboev, *Traction characteristics of TTZ 1030 cultivator tractor tire at low air pressures*, **2**, 83-85 (Mechanical problems, Tashkent, 2013)
14. A. R. Normirzaev, A. D. Nuriddinov, *Impact of wheeled and tracked tractor propellers on crop productivity Collection of articles of the twenty-second international scientific conference. (Techno Congress, Russia, 2018)* **26**, 7-11

15. M. A. Tukhtabaev, *Results of experimental investigations on reducing the compacting impact on the soil of tires* Proc. Int. Conf. on Ecological aspects of land use in modern economic formations, 426-429 (2017)
16. M. A. Tukhtabaev, *Scientific bases of choosing the tires for agricultural tractors*, 104 (2016)
17. M. A. Tukhtabayev, *Resource-saving technology for saving of soil fertility*, Proc. Int. scientific-practical Conf. dedicated to the 30th anniversary of the system of dry farming in Volgograd region on Scientifically grounded systems of dry farming in modern conditions, **17**, 43-45 (Volgograd GAU, 2016)
18. F. Hasanova, Sh. Abdualimov, B. Niyazaliev, *Care of young cotton seedlings*, J. Agriculture of Uzbekistan, **5**, 2-3 (Tashkent, 2017)
19. A. H. Hojiev, S. U. Temirov, *Universal working body for cotton cultivator*, J. Agro ILM (Scientific application of the Journal of Agriculture of Uzbekistan) **1**(57), 88 (Tashkent 2019)
20. M. A. Tukhtaboey, *Environmental assessment of wide-scale machine-tractor units*, Proc. Int. Conf. on Modern Trends in the Development of the Agrarian Complex, 272-275 (2016)
21. A. Talibaev, M. Tukhtabaev, R. Obidov, J. Temirov, M. Khamzaev, *Innovative production of raw cotton technology*, Int. J. Advanced Research in Science, Engineering and Technology (IJARSET), **6**/9 (2019)
22. A. Nuriddinov, A. Nasritdinov, A. Normirzaev, *Development of aggregates for the main and pre-sowing soil cultivation for sowing catch crops*, Scientific and technical journal Fergana Polytechnic Institute, **3**, 53-56 (Fergana, 2015)
23. A. A. Khozhiev, A. Tukhtakuziev, S. U. Temirov, Bulletin **4**, Patent of the RUz. No. FAP 01367 Working body of row cultivator (2019)