

Continuous synthesis and transformation of diazomethane

Mengqi Dong^{1a}, Dawei Teng^{1b} and Guorui CAO^{1c*}

¹School of Chemical Engineering, Qingdao University of Science and Technology, Shandong 266042, China

Abstract—Diazomethane is the simplest diazo compound with high reactivity and is an exceptionally versatile C₁-building block. However, diazomethane's application is greatly limited due to its special properties such as highly toxic, carcinogenic, inflammable and explosive. The application of the one-pot reaction and emerging continuous flow technology in the field of hazardous chemicals enable the generated diazomethane to be directly consumed and transformed, effectively ensuring the safety of the reaction process and providing the possibility for its mass production and use. According to the different precursors of diazomethane, the applications of diazomethane in continuous synthesis and in situ transformation in laboratory and industry are systematically summarized.

1. Introduction

As the simplest diazo compound, Diazomethane (CH₂N₂) has high reactivity and can be used in various transformations with only nitrogen by-products (Fig.1).^[1-3] But safe production of diazomethane is difficult due to its high carcinogenicity, extreme instability and high volatility, requiring specific safety precautions and

dedicated equipments even in very small-scale preparations.^[4] In addition, the reaction releases equivalent amounts of nitrogen, resulting in a significant increase in pressure under mass production conditions, increasing the risk of the process and greatly limiting its use in laboratory and industrial production.^[5-7] As a result, people are working to develop a variety of methods to use CH₂N₂ in safe and controllable conditions.

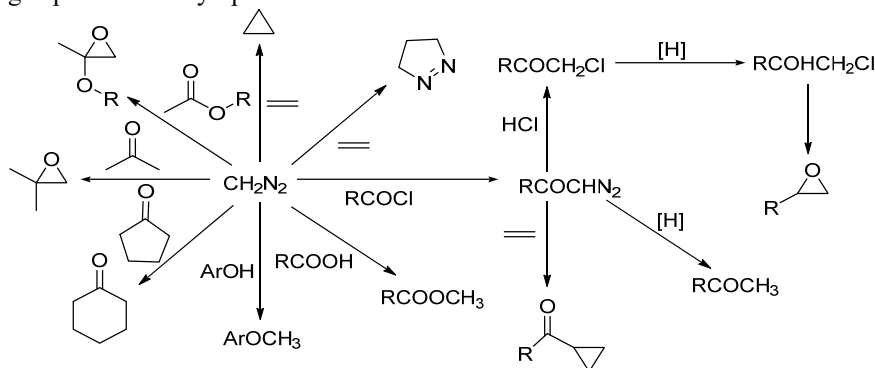

Fig.1 The conversion path of diazomethane

One-pot reaction has been developed to realize the continuous generation and transformation of CH₂N₂. In addition, the emerging continuous flow technology has been widely used in the total synthesis of natural products and drug intermediates synthesis due to its good mass and heat transfer effect and accurate parameter control, which can ensure the safe and efficient reaction of dangerous CH₂N₂ under continuous flow conditions.^[8-9] Based on two commonly used precursors N-Methyl-N-nitrosourea (MNU) and N-Methyl-N-nitrosotoluene-4-sulphonamide (Diazald), the continuous synthesis and

transformation of CH₂N₂ in recent ten years were summarized.

2. Preparation of CH₂N₂ using MNU

MNU can be alkylated to CH₂N₂ at lower temperatures and can be readily prepared in one step from the inexpensive and harmless N-Methylurea, making it well suited for continuous processes (Fig.2).^[10]

^a17854225255@163.com, ^bdtengw@163.com, ^{c*}caogurui@qust.edu.cn

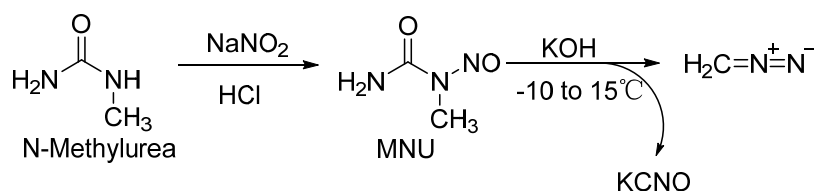

Fig.2 Synthesis of diazomethane using MNU

2.1. One pot-two phases method

In 2019, Shulishov used a one-pot method with a biphasic solvent system to realize the continuous generation and direct participation of CH_2N_2 in the

cyclopropanation reaction of spiro[2.4]hepta-4,6-diene (SHD) (Fig.3).^[11] CH_2N_2 generated by MNU under alkali action continuously diffused to organic phase from water phase, and cyclopropane products were prepared under Pd(II) catalysis.

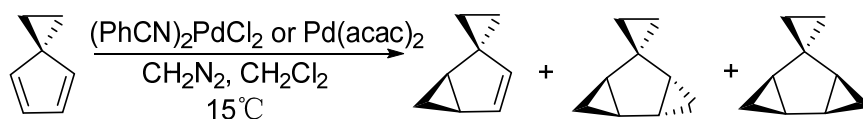

Fig.3 Cyclopropanation of SHD with diazomethane

2.2. Continuous flow process

In 2011, Rossi reported the preparation of CH_2N_2 from MNU in Corning GEN1 microflow reactor at a

production scale of 19 mol/d.^[12] The mixed solution after the reaction was directly channeled into the ethanol solution of benzoic acid, and the final yield of methyl benzoate reached 75% (Fig.4).

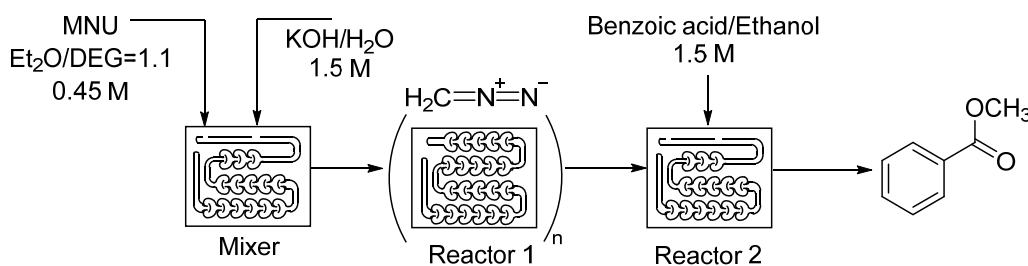

Fig.4 Continuous production of diazomethane using MNU

In 2016, Garbarino used a tube-in-flask reactor for the semi-intermittent synthesis of α -chloroketone with a maximum yield of 96% (Fig.5).^[13] CH_2N_2 synthesized in two steps from N-Methylurea diffused into conical flask

through hydrophobic Teflon AF-2400 membrane to react with anhydride to produce α -diazoketone. Then the α -chloroketone was synthesized by adding hydrochloric acid in batches.

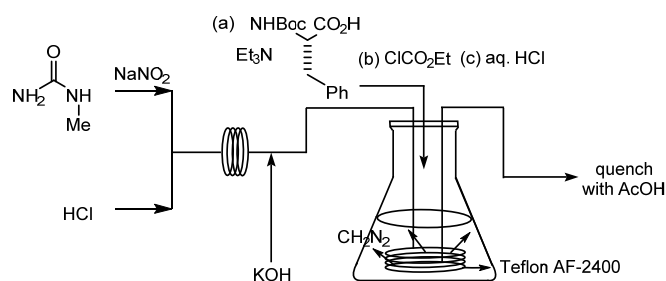

Fig.5 Synthesis of α -chloroketone in a tube-in-flask reactor

In 2017, Lehmann used two LL-phase separators to develop a two-step process of preparing CH_2N_2 with N-Methylurea at a scale of 4.9 g/h (Fig.6).^[14] After the reaction, the mixed solution was passed into the LL-phase separator to remove the impurities in the water

phase. Finally, the organic solution of CH_2N_2 was directly passed into aryl formic acid to obtain the corresponding aryl methyl ester, with the yield above to 98%.

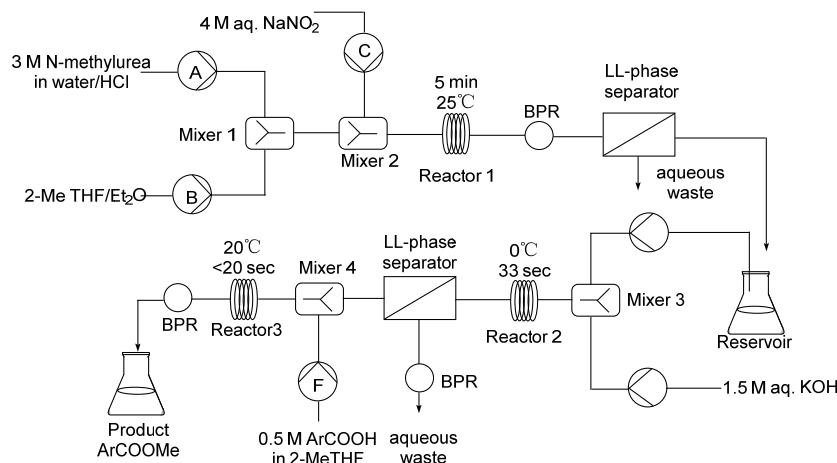

Fig.6 Process for the preparation of CH_2N_2 using two LL-phase separators

In 2020, Hong used the extraction column instead of available LL-phase separator to achieve continuous preparation of CH_2N_2 from N-Methylurea, and finally sent it to the reactor for freezing and dehydrating (Fig.7).^[15]

The solution can undergo methylation reaction with carboxylic acid and Arndt-Eistert reaction with anhydride to prepare α -diazoketone.

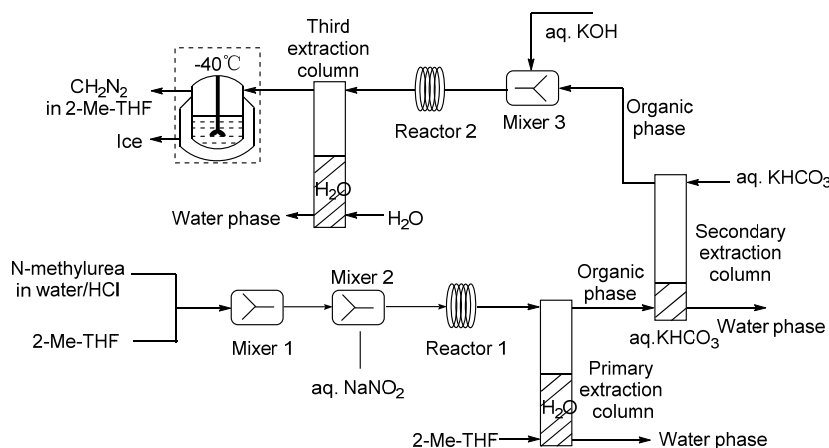

Fig.7 Process for the preparation of CH_2N_2 using extraction column.

3. Preparation of CH_2N_2 using Diazald

Diazald can be synthesized from *p*-toluene sulfonyl chloride through the amidation and nitrosation. It is

stable at room temperature and reacts with a base to form CH_2N_2 under mild conditions, which has become the most widely used precursor (Fig.8).^[16]

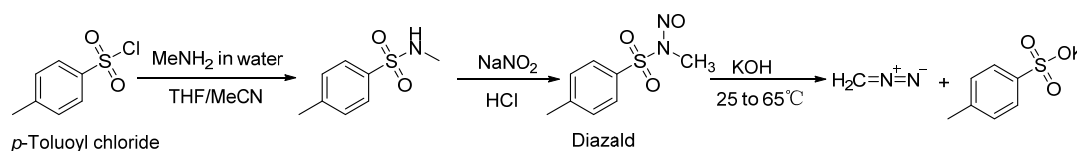

Fig.8 Synthesis of diazomethane using Diazald

3.1. One pot-two phases method

In 2012, Morandi proposed a reaction model for the cyclopropanation of olefin catalyzed by FeTPPCL via CH_2N_2 preparation and direct participation in a two-phase system (Fig.9).^[17] The water phase contained alkali

and Diazald analogizes, in which the generated CH_2N_2 continuously diffused to the organic phase to form a metal-carbene intermediate with the catalyst, which was continuously captured by the surrounding substrate for reaction.

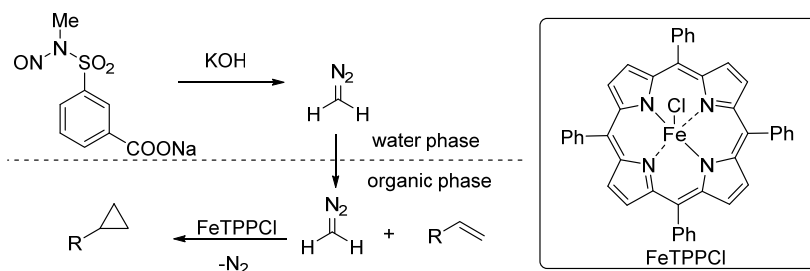

Fig.9 Two-phase model for the iron-porphyrin-catalyzed cyclopropanation

3.2. Continuous flow process

In 2010, Hong injected Diazald and alkali into the upper chamber of the reactor (a) from the feeding port to generate CH_2N_2 , and the excess reaction liquid flowed

into the lower reaction center (b) from the overflow port to continue the reaction.^[18] Meanwhile, nitrogen gas was injected to bring the produced CH_2N_2 out as a gas (Fig.10).

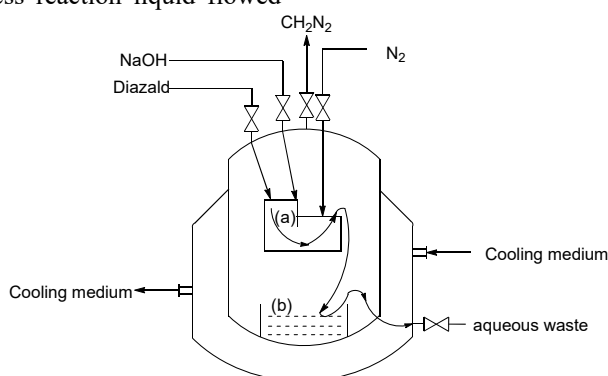

Fig.10 Continuous production of diazomethane using tank reactor

In 2011, He used the microreactor technology to synthesize CH_2N_2 at a rate of 22.3 mol/d, and proposed a reasonable transesterification and ester hydrolysis side reaction mechanism for subsequent methylation reaction (Fig.11).^[19] Finally, the side reaction was completely inhibited by respectively using dimethyl sulfoxide as the solvent of the precursor and methanol as the solvent of carboxylic acid. The yield could reach 100%.

engineering on this basis. It was found that the water content in the system was the key factor affecting the yield, which was assumed to be due to the rapid decomposition of CH_2N_2 in water.^[20] In 2020, Duan used this process to investigate the potential mechanism of the influence of different alcohol solvents on methylation of benzoic acid, further demonstrating the existence of transesterification.^[21]

In 2019, Yang studied the methylation of benzoic acid from the perspective of chemical reaction and

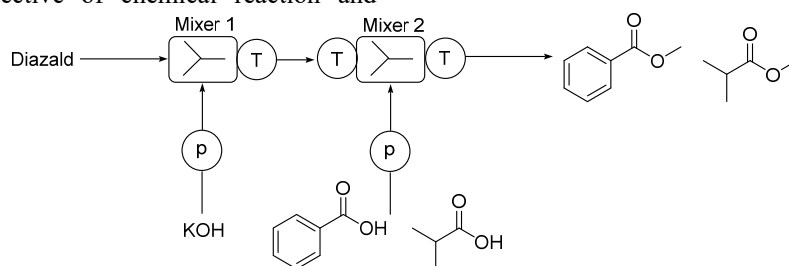

Fig.11 Continuous microreaction for generation and conversion of diazomethane

In 2011, Maurya proposed a two-channel microreactor separated by Polydimethylsiloxane (PDMS) membranes and coated with Polyvinylsilazane (PVSZ) for the continuous generation, separation and consumption of anhydrous CH_2N_2 (Fig.12).^[22] CH_2N_2

was produced by the reaction of Diazald and potassium hydroxide in the bottom channel and diffused through the membrane to react with the substrate in the upper channel to obtain the corresponding product with the yield of more than 80%.

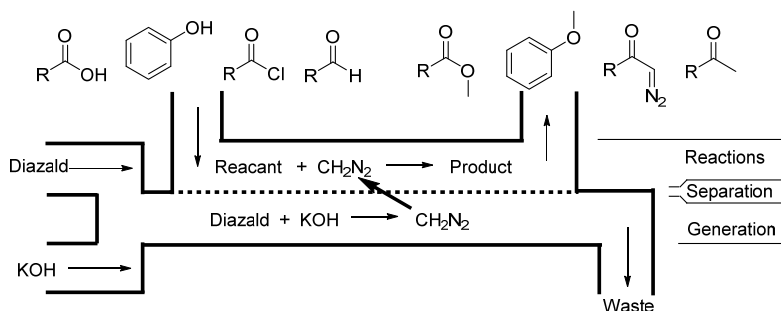

Fig.12 Generation and reaction of diazomethane in dual-channel microreactor

In 2013, Zhang built a simple CH_2N_2 generating and reacting device which had good applicability to 16 kinds of acids (Fig.13).^[23] CH_2N_2 gas prepared from Diazald

was continuously spilt from the small hole in the upper part of the sealed inner tube, and then dissolved in acid solution of conical flask for methylation reaction.

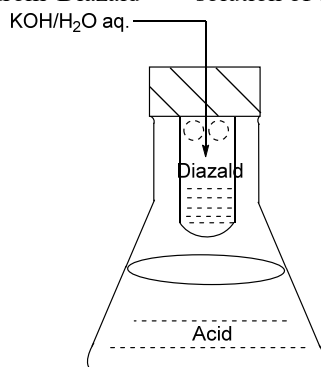

Fig.13 A simple Diazomethane generating and reacting device

In 2010, Koolman used the tube-in-tube reactor to study Pd-catalyzed cyclopropanation of arylcyclopropyl borate compounds (a),^[24] and for the first time synthesized several novel multifunctional arylcyclopropyl borate compounds in 45~72% yield (Fig.14). In 2013, Mastronardi developed a continuous process for the preparation of anhydrous CH_2N_2 at a rate of 35 mmol/d using this reactor.^[25] CH_2N_2 prepared from Diazald diffused through the membrane to the outer tube for methylations of various nucleophiles, [2+3]

cycloadditions and cyclopropanations of alkenes (b).

In 2014, Pinho used a tube-in-tube reactor to synthesize chiral α -haloketone with a yield of 87% at a flow rate of 1.25 mmol/h.^[26] The Arndt-Eistert reaction between CH_2N_2 and activated amino acids in the outer cavity yielded α -diazoketone (c), which was finally halogenated in batches to obtain α -haloketone. In the same year, the team achieved the synthesis of β -amino acids from α -diazoketone with 34~54% yield.^[27]

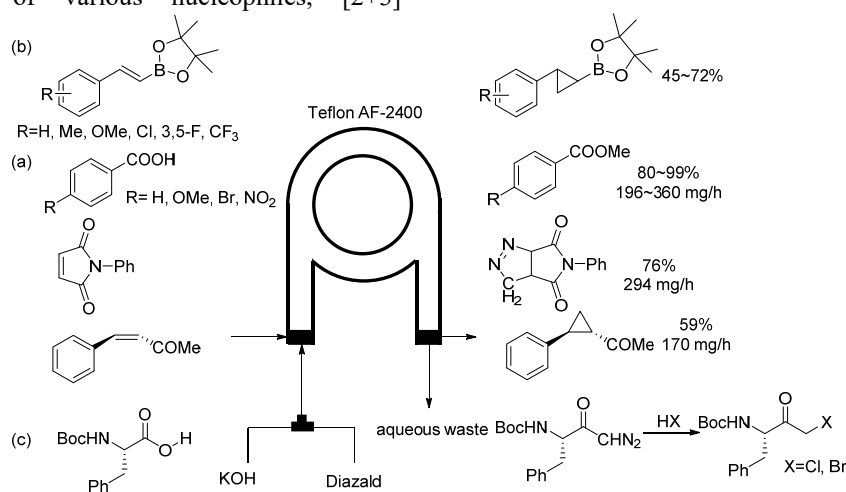

Fig.14 Reaction of diazomethane in the tube-in-tube reactor

In 2014, McKee used CH_2N_2 gas to directly participate in the cyclopropanation of 7-oxabenzonorbornadienes, and synthesized a series of cyclopropanes with good yields (Fig.15).^[28] CH_2N_2 was directly co-distilled with nitrogen when sodium

hydroxide aqueous solution was dropped into diethyl ether solution of Diazald, and the gas mixture was directly passed into the reaction bottle containing catalyst and substrates.

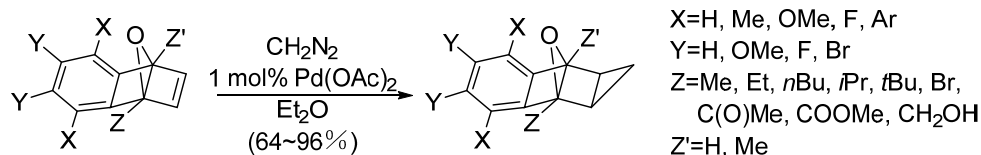

Fig.15 Cyclopropane reaction of C1- and aryl-substituted oxabenzonorbornadienes

In 2016, Carlson investigated the reaction effect of 7-Oxabicyclic substrates with bulky C1 or C2 groups, and the yield was good to excellent.^[29] In addition, the

cyclopropanation of 2,3-diazodicyclic olefin was reported for the first time with yields exceeding 90% (Fig.16).

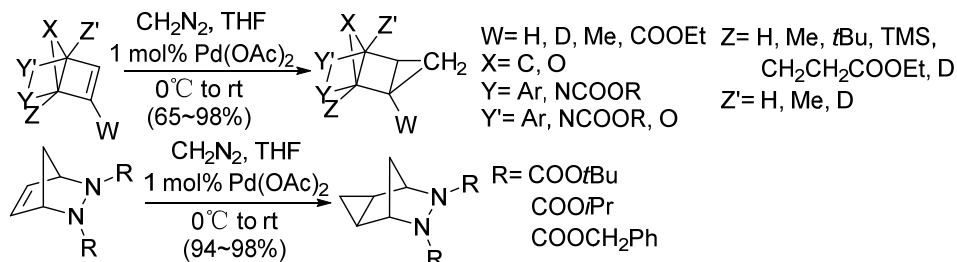

Fig.16 Cyclopropanation reaction for the synthesis of [2.2.1]heterocyclic bicyclic olefin

In 2016, Dallinger applied the tube-in-flask reactor to produce CH_2N_2 from Diazald with a final production scale of 3.9 mg/min.^[30] Then Methyl esterification of carboxylic acids (a), synthesis of α -haloketone (b),

synthesis of pyrazole (c) and Pd-catalyzed cyclopropanation (d) were performed with yields above 71% (Fig.17).

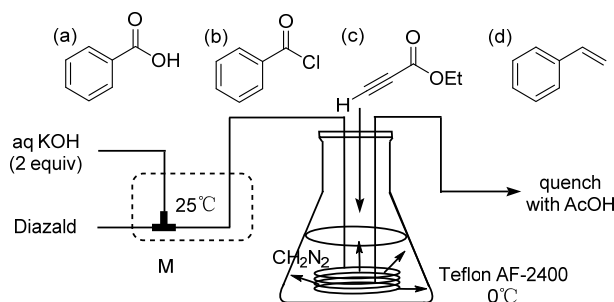

Fig.17 Reaction of diazomethane in the tube-in-flask reactor

In 2019, Wernik developed a continuous stirred tank reactor (CSTR) tandem tubular reactor for three-step synthesis of chiral α -chloroketone at a rate of 1.54 g/h (Fig.18).^[31] CH_2N_2 prepared from Diazald in the first CH_2N_2 generator diffused through the membrane to the

first CSTR and reacted with activated amino acids to obtain α -diazoketone. To further increase the yield, a similar second device was set up and then α -haloketone was synthesized by halogenation in batches.

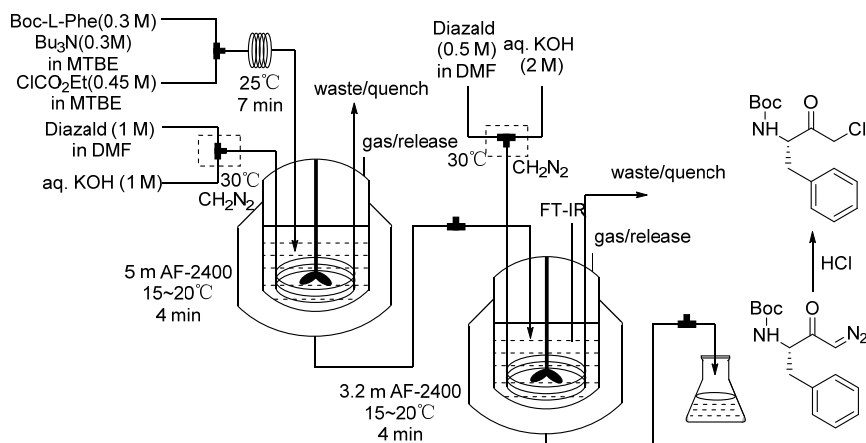

Fig.18 Synthesis of α -chloroketone in the CSTR cascade

In 2021, Sheeran developed a translational flow reactor (PFR) that achieved the production of CH_2N_2 at a rate of 0.44 mol/h (Fig.19).^[32] After the reaction, the mixed solution passed through a GL-phase separator equipped with a selectively permeable hydrophilic

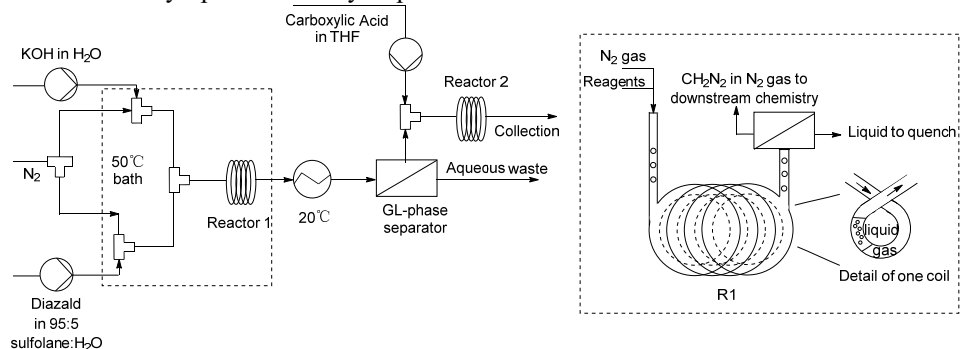

Fig.19 Synthesis of diazomethane in PFR reactor and downstream process

4. Conclusion

CH_2N_2 is widely regarded as a useful reagent that can promote various chemical transformations especially methylation and cyclopropanation. It has important applications in pharmaceutical synthesis and fine chemical industry. However, the toxicity, instability and inflammability of CH_2N_2 greatly increase the difficulty of production and limit its application in industry. In this paper, the applications in the continuous synthesis and transformation of CH_2N_2 in the past decade are summarized, and the continuous processes involving methylation, cyclopropanylation and Arndt-Eistert reaction at laboratory and industrial scales are described. However, the current processes only focus on verifying the feasibility of classical transformation of CH_2N_2 , and there are few studies on new reactions and large production scale. Therefore, the development of new process routes and experimental devices for efficient large-scale synthesis and use of CH_2N_2 under the premise of ensuring safe production will be the focus of future research.

References

1. Barbosa, A.G.H., Monteiro, J.G.S. (2012) On the electronic structure of the diazomethane molecule. *Theor Chem Acc.*, 131: 1-16.
2. Tang, M., Xing, D., Cai, M.Q., et al. (2014) Diazo Compounds-Involved Catalytic Asymmetric Multicomponent Reactions. *Chinese J Org Chem.*, 34: 1268-1276.
3. Ford, A., Miel, H., Ring, A., et al. (2015) Modern organic synthesis with α -diazocarbonyl compounds. *Chem Rev.*, 115: 9981-10080.
4. Green, S.P., Wheelhouse, K.M., Payne, A.D., et al. (2019) Thermal stability and explosive hazard assessment of diazo compounds and diazo transfer reagents. *Org Process Res Dev.*, 24: 67-84.
5. Müller, S.T.R., Wirth, T. (2015) Diazo Compounds in Continuous-Flow Technology. *ChemSusChem.*, 8: 245-250.
6. Movsisyan, M., Delbeke, E.I.P., Berton, J., et al. (2016) Taming hazardous chemistry by continuous flow technology. *Chem Soc Rev.*, 45: 4892-4928.
7. Gao, Y.P., Wang, J.B. (2018) Continuous Flow Reaction of Diazo Compounds. *Chinese J Org Chem.*, 38: 1275-1291.
8. Martin, L.J., Marzinzik, A.L., Ley, S.V., et al. (2011) Safe and reliable synthesis of diazoketones and quinoxalines in a continuous flow reactor. *Org Lett.*, 13: 320-323.
9. Yang, H., Martin, B., Schenkel, B. (2018) On-demand generation and consumption of diazomethane in multistep continuous flow systems. *Org Process Res Dev.*, 22: 446-456.
10. Pearce, M. (1980) The Rates of Diazomethane Formation from Methylnitrosoamides. The stability of diazomethane solutions towards aqueous alkalis. *Helv Chim Acta.*, 63: 887-891.
11. Shulishov, E.V., Pantyukh, O.A., Menchikov, L.G., et al. (2019) Catalytic cyclopropanation of spiro[2.4]hepta-4,6-diene with diazomethane. *Tetrahedron Lett.*, 60: 2043-2045.
12. Rossi, E., Woehl, P., Maggini, M. (2011) Scalable in situ diazomethane generation in continuous-flow reactors. *Org Process Res Dev.*, 16: 1146-1149.
13. Garbarino, S., Guerra, J., Poehlauer, P., et al. (2016) One-pot synthesis of α -haloketones employing a membrane-based semibatch diazomethane generator. *J Flow Chem.*, 6: 211-217.
14. Lehmann H. (2017) A scalable and safe continuous flow procedure for in-line generation of diazomethane and its precursor MNU. *Green Chem.*, 19: 1449-1453.
15. Hong, H., Lu, J.P., Zhang, E.X., et al. (2020) W.O. Patent 2020/232625.
16. Shields, S.W.J., Manthorpe, J.M. (2014) Manthorpe, Efficient, scalable and economical preparation of tris(deuterium)- and ^{13}C -labelled N-methyl-N-nitroso-p-toluenesulfonamide (Diazald[®]) and their conversion to labelled diazomethane. *J Labelled Compd Rad.*, 57: 674-679.
17. Morandi, B., Carreira, E.M. (2012) Iron-catalyzed cyclopropanation in 6 M KOH with in situ

- generation of diazomethane, *Science.*, 335: 1471-1474.
18. Hong, H., Tao, J., Guo, X.W., et al. (2010) C.N. Patent 10184406.
 19. He, K. (2011) On-site Synthesis and In-situ Conversion of Diazomethane in Micro-reactor. Shanghai: East China University of Science and Technology.
 20. Yang, C., Shi, Y., He, K., et al. (2019) Understanding of two-stage continuous microreaction technology for in-situ generation and consecutive conversion of diazomethane. *J Taiwan Inst Chem E.*, 98: 94-98.
 21. Duan X., Huang Z., Qian G., et al. (2020) Unprecedented yield of methyl-esterification with in-situ generated diazomethane in a microchannel reactor with methanol as solvent. *Chem Eng Sci.*, 213: 115397.
 22. Maurya, R.A., Park, C.P., Lee, J.H., et al. (2011) Continuous in situ generation, separation, and reaction of diazomethane in a dual-channel microreactor. *Angew.*, 50: 5952-5955.
 23. Zhang J. A Simple Method and Apparatus for Producing Diazomethane. (2013) *Guangdong Chemical Industry.*, 40: 116-117.
 24. Mastronardi, F., Gutmann, B., Kappe, C.O. (2013) Continuous flow generation and reactions of anhydrous diazomethane using a teflon AF-2400 tube-in-tube reactor. *Org Lett.*, 15: 5590-5593.
 25. Koolman, H.F., Kantor, S., Bogdan, A.R., et al. (2016) Automated library synthesis of cyclopropyl boronic esters employing diazomethane in a tube-in-tube flow reactor. *Org Biomol Chem.*, 14: 6591-6595.
 26. Pinho, V.D., Gutmann, B., Miranda, L.S.M., et al. (2014) Continuous flow synthesis of α -halo ketones: essential building blocks of antiretroviral agents. *J Org Chem.*, 79: 1555-1562.
 27. Pinho, V.D., Gutmann, B., Kappe, C.O. (2014) Continuous flow synthesis of β -amino acids from α -amino acids via Arndt-Eistert homologation. *Rsc Adv.*, 4: 37419-37422.
 28. McKee, M., Haner, J., Carlson, E., et al. (2014) Synthesis of cyclopropanated 7-oxabenzonorbornadienes. *Synthesis.*, 46: 1518-1524.
 29. Carlson, E., Duret, G., Blanchard, N., et al. (2016) Synthesis of cyclopropanated [2.2.1] heterobicycloalkenes: An improved procedure. *Synthetic Commun.*, 46: 55-62.
 30. Dallinger, D., Pinho, V.D., Gutmann, B., et al. (2016) Laboratory-scale membrane reactor for the generation of anhydrous diazomethane. *J Org Chem.*, 81: 5814-5823.
 31. Wernik, M., Poehlauer, P., Schmoelzer, C., et al. (2019) Design and optimization of a continuous stirred tank reactor Cascade for membrane-based diazomethane production: synthesis of α -Chloro ketones. *Org Process Res Dev.*, 23: 1359-1368.
 32. Sheeran, J.W., Campbell, K., Breen, C.P., et al. (2020) Scalable on-demand production of purified diazomethane suitable for sensitive catalytic reactions. *Org Process Res Dev.*, 25: 522-528.