

# Effect of dam removal of small hydropower station on migration and distribution of biogenic elements: Progress and prospects

Cai Li<sup>1,2,\*</sup>, Linjie Guan<sup>1,2</sup>, Kun Yang<sup>1,2</sup>, Li Zhang<sup>1,2</sup>, Qingsong Fan<sup>1,2</sup>

<sup>1</sup> Changjiang Spatial Information Technology Engineering Co., Ltd., Wuhan 430010, China

<sup>2</sup> Hydro information Perception and Big Data Engineering Technology Research Center of Hubei Province, Wuhan 430010, China

**Abstract:** The small hydropower stations have reached a new balance after years of operation. The ecological balance of the river would be broken by the dam removal and the reservoir area above the dam would disappear. Consequently, a series of changes occurred in water depth, velocity of flow, the concentration of organic and inorganic nutrients, distribution and form of organic matter, aquatic organism, etc. It is unclear what would happen for the hydrodynamic conditions, sediment characteristics and aquatic organism community structure of the reservoir area and the lower reaches after the dam removal. Therefore, it is urgent to study the impact of dam removal on the transportation and redistribution of organic debris and the potential ecological effects with benthos as indicators in the river where the small hydropower station is located.

**Keywords:** biogenic elements; organic detritus; distribution and morphology; diversion-type small hydropower station; dam removal

## 1. Introduction

According to statistics, there were 24100 small hydropower stations in the Yangtze River Economic Belt of China by the end of 2017. In a specific historical period, these small hydropower stations have played a huge role in energy utilization, Replacing firewood with electricity, energy conservation and emission reduction. Due to poor management and operation, some small hydropower stations have led to the cutoff of some small and medium-sized rivers, which has affected the transmission of river material and energy and the community structure of aquatic organisms to a certain extent. This furtherly has had a certain impact on the river ecological environment of the river. In China, most of small hydropower stations were built in the 1960s and 1970s, and most of them have been in operation more than 30 years. Consequently, the physical and chemical characteristics and the aquatic biological community of the river located by the small hydropower station have reached a new balance through natural selection and succession.

In December 2018, the Opinion on the Classification and Rectification of Small Hydropower Stations in the Yangtze River Economic Belt have been jointly issued by the Ministry of Water Resources and three other departments of China. Relevant departments of provinces and cities in the Yangtze River Economic Belt should carry out assessment, classification, rectification and management for these small hydropower stations, according to the issued opinion. The small stations are

required to be divided into three categories: immediate demolition stations, timed shutdown stations and guided rectification stations. For the immediate demolition stations, the dam and ancillary facilities should be partially or completely removed in principle, those of which with comprehensive benefits such as flood control, irrigation and water supply, the dam or diversion canal can not be removed, but complete discharge and monitoring facilities for ecological flow are ensured. For the timed shutdown stations, it is required to complete reconstruction of discharge facilities and installation of monitoring equipment for ecological flow and connect to the provincial ecological flow monitoring platform. The ecological balance of the river would be broken by the dam removal and the reservoir area above the dam would disappear. The upstream water habitat of the dam would be restored from a still water reservoir to a flowing river channel. Consequently, a series of changes occurred in water depth, velocity of flow, the concentration of organic and inorganic nutrients, distribution and form of organic matter, aquatic organism, etc. What would happen for the hydrodynamic conditions, sediment characteristics and aquatic organism community structure of the reservoir area and the lower reaches after the dam removal? Positive or negative? Single or cumulative? How would the change of tributary water environment affect the main stream? These are not clear at present and need for further research.

\* Corresponding author: 476530436@qq.com

## 2. Influence of dam removal on distribution and morphology of biogenic elements

According to the River Continuum Concept (Vannote et al., 1980), from the source to the open lower reaches the river is a continuous, flowing, unique and complete ecosystem, the exogenous and endogenous nutrients of which are characteristic of continuous changes. The transport of biogenic elements is of great significance to the river ecosystem and has always been a hotspot in the study of the watershed geochemical material cycle. The main forms of biogenic elements from different sources (including internal and external sources) in reservoirs were shown in Table 1 (Deng et al., 2018). The biogenic elements in rivers are transported, floated and transformed under the combined physical, chemical and biological effects of climate, landform, animals, plants, microorganisms, etc., taking water and sand as carriers (Han et al., 2014; Maavara et al., 2014; Marx et al., 2017). Biogenic substances, as important environmental elements and the foundation of river ecosystem, physical sedimentation, have different chemical dissolution, mineralization and bio-absorption processes in the reservoir due to their different properties and functions, thus further leading to changes in retention efficiency and chemometric characteristics of biogenic elements. The cyclic process of reservoir biogenic elements was shown in Figure 1 (Deng et al., 2018).

**Table 1** The main forms of biogenic elements in reservoirs (Deng et al., 2018)

Elements	Main forms
C	POC (Particle Organic Carbon), PIC (Particle Inorganic Carbon), DOC (Dissolved Organic Carbon), DIC (Dissolved Inorganic Carbon)
	PON (Particle Organic Nitrogen), DON (Dissolved Organic Nitrogen), DIN (Dissolved Inorganic Nitrogen, including NO <sub>x</sub> -N and NH <sub>4</sub> -N)
	TDP (Total Dissolved Phosphorus), POP (Particle Organic Phosphorus), EP (Exchangeable Phosphorus), UPP (Unreactive Particle Phosphorus)
Si	DSi (Dissolved Silicon), PSi (Particle Silicon), SSi (Sediment Silico), BSi (Biogenic Silicon)

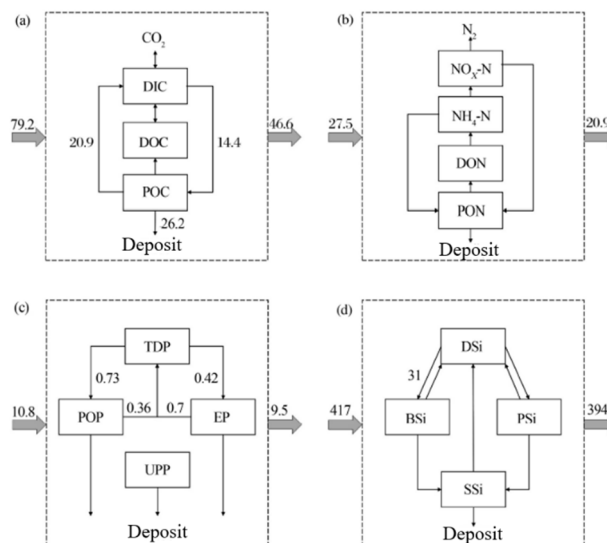

**Fig. 1** Biogenic elements cyclic processes in reservoirs (The wide arrows refer to the inflow and outflow fluxes and the dotted box refers to the cycle process of each element in the reservoir. The unit is Tg/a) (Deng et al., 2018)

The classification and rectification of small hydropower stations, particularly these with removing barrage or blocking the water intake would significantly change the hydrological regime characteristics (including flow, water level, water depth, flow velocity and wet perimeter, etc.) of the original river channel. Consequently, the reservoir reach upstream of the dam would change from still water habitat to flowing water habitat, and the water reach under the dam would change from a water reducing or cutoff reach to a rapid flow river reach, with significant changes in water depth and flow velocity. At the same time, a large number of sediments intercepted and accumulated in the upstream reservoir area of the barrage for many years including organic detritus and other biogenic substances would be transported to the downstream river section, with the removal of water retaining structures or the increase of discharge flow. The change of sediment type and composition of different affected river sections might further affect benthos, plankton, fish and other aquatic biological communities and their habitats. At present, there is little research and attention on the impact of dam demolition of diversion run-of-river small power station on organic debris and its ecological effects in river ecosystems in China.

## 3. Influence of dam removal on transport and decomposition of organic debris

Limited by the development stage of small hydropower and the research area and research objects, there are relatively few studies on the impact of dam demolition on the ecological environment in China at present. Some studies qualitatively describe the ecological impact of dam demolition, lacking of on-site observation and systematic quantitative research. In United States largest number of dams have been demolished and some relevant researches on the impact by dam demolition have been done. The evolution of upstream and downstream rivers

after dam demolition and the impact of dam demolition on plants in the bank zone have been studied (Doyle et al., 2003; Kim et al., 2015).

Studies have shown that suspended particulate organic detritus and sediment organic detritus in most rivers, especially large rivers, are mainly exogenous (Tesi et al., 2007), and part of coarse particulate organic detritus (CPOM) are derived from plant leaves (Devol and Hedges, 2001). On the whole, river organic matter is also mainly from external sources. For some small watersheds with little human disturbance, the source of river organic matter may mainly be the photosynthesis of algae in the water body. The source of suspended particulate organic carbon and nitrogen of rivers and lakes in some plain areas have been studied by domestic researchers using stable isotope technology (Li et al., 2011; Wang et al., 2014).

The research shows that all the organic matter in the river have been transported in the form of coarse particles at the beginning. The output of coarse suspended solids is characteristic of obvious seasonal trend and randomness and most of them occurred in flood seasons (Ni et al., 2013). It was shown that different nutrient sources possess greater influence on the coarse sediment organic debris than that on the fine organic debris in rivers (Tant et al., 2013). The decomposition of organic detritus in rivers includes two main processes: rapid weight loss in the initial stage due to leaching and decomposition due to invertebrate feeding and mechanical damage. The leaching stage is mainly the abiotic loss of soluble components, which largely depends on the activities of decomposers in the decomposition stage (Xiong and Nilsson, 1997). The biological factors affecting the decomposition rate of organic detritus are mainly related to the activities of invertebrates and microorganisms in rivers. The abiotic factors include temperature and hydro-chemical characteristics. The effect of nitrogen in lakes dominated by submerged plants on organic matters from the sediment has been studied by using fluorescence spectroscopy (Yao et al, 2015).

#### **4. Influence of dam building on form and distribution of organic debris**

There were few studies on the impact of dam removal of small hydropower stations on the organic debris in the sediment. Considering that dam removal and dam construction are two relative processes, comparative analysis can be carried out in some aspects. The influence on form and distribution of organic debris under the dam construction were demonstrated. The main impact of dam construction on rivers is that the discharge of downstream reach reduced obviously, thus reducing the area of aquatic habitats, the continuity (Anderson et al., 2006; James et al., 2008) and the assimilation capacity (Liu, et al. 2005) relative to the original river. Although a small low dam can still continue to affect the transport (Nislow et al, 2011) and utilization efficiency of the river organic matter (von Schiller et al., 2011).

Whether low or high dams are formed by hydropower stations, they can intercept organic matter (Flores et al., 2011; Sanchez-Vadal et al., 2013), thus reducing the input

of organic matter in the downstream. To some extent, the reduction of water flow in the downstream reach caused by the dam barrier would promote the accumulation of organic matter (Brookshire and Dwire 2003; Dewson et al., 2007). Organic matter was distributed and balanced under the influence of these two opposite actions with the regional specificity. Gessner and Chauvet (2002) suggested that the changes of organic matter accumulation rule and other biological and abiotic factors may lead to the reduction of the decomposition rate of organic matter in water bodies. Other studies showed that the water intake of diversion run-of-river small power stations has significantly changed the storage and decomposition of coarse organic debris in rivers in winter and the number of predators of macroinvertebrate benthos is also significantly reduced (Arroita et al., 2015). At present, the impact of dam construction on organic debris was mainly concentrated on dissolved and suspended organic matter under the impact of large-scale hydraulic projects. The research on organic debris of sediment in mountain rivers under the dam removal of small diversion hydropower stations is almost blank.

#### **5. Research prospects and suggestions**

To sum up, the current research is mainly focused on suspended or dissolved organic matter in water bodies in plain areas, and the research on organic debris in sediment is mainly focused on the relationship with benthos and other organisms. The foreign reports are also focused on the impact of damming on organic debris in sediment and there is almost no research on the organic detritus in the sediment of rivers in mountainous areas under the dam demolition of small diversion hydropower stations. In the future, it is suggested to carry out researches from the following aspects: the distribution rule of organic debris in the sediment of the river reach affected by the diversion type small hydropower station; the characteristics and mechanism of the influence of dam removal on the transport flux and distribution of organic detritus in the sediment; the relationship between organic detritus of sediment and hydraulic characteristics such as water velocity and depth; ecological effects of changes in organic detritus of sediment with benthos as indicator organisms.

#### **Acknowledgments**

This work was financially supported by Exploratory pilot Project of Digital Twin Danjiangkou Reservoir of Middle-Line South-to-North Water-Transfer Project (Grant No. GXTC-C-22870043).

#### **References**

1. Anderson E P, Freeman M C, Pringle C M. Ecological consequences of hydropower development in Central America: impacts of small dams and water diversion on neotropical stream fish

- assemblages [J]. *River research and applications*, 2006, 22(4): 397-411.
2. Arroita M, Aristi I, Díez J, et al. Impact of water abstraction on storage and breakdown of coarse organic matter in mountain streams [J]. *Science of the Total Environment*, 2015, 503: 233-240.
  3. Brookshire E N J, Dwire K A. Controls on patterns of coarse organic particle retention in headwater streams [J]. *Journal of the North American Benthological Society*, 2003, 22(1): 17-34.
  4. Devol A H, Hedges J I. Organic matter and nutrients in the mainstem Amazon River [J]. *The biogeochemistry of the Amazon basin*, 2001, 15: 275-306.
  5. Dewson Z S, James A B W, Death R G. Stream ecosystem functioning under reduced flow conditions [J]. *Ecological Applications*, 2007, 17(6): 1797-1808.
  6. Doyle M W, Stanley E H, Selle A R, et al. Predicting the depth of erosion in reservoirs following dam removal using bank stability analysis [J]. *International Journal of Sediment Research*, 2003, 18(2): 115-121 .
  7. Flores L, Larranaga A, Díez J, et al. Experimental wood addition in streams: effects on organic matter storage and breakdown [J]. *Freshwater Biology*, 2011, 56(10): 2156-2167.
  8. Gessner M O, Chauvet E. A case for using litter breakdown to assess functional stream integrity [J]. *Ecological applications*, 2002, 12(2): 498-510.
  9. Han H, Lu X, Burger D F, et al. Nitrogen dynamics at the sediment- water interface in a tropical reservoir [J]. *Ecological Engineering*, 2014, 73:146-153.
  10. James A B W, Dewson Z S, Death R G. The effect of experimental flow reductions on macroinvertebrate drift in natural and streamside channels [J]. *River research and Applications*, 2008, 24(1): 22-35.
  11. Kim S, Toda Y, Tsujimoto T. Geomorphological and riparian vegetation responses following a low-head dam removal: a study based on literature review [J]. *International Journal of River Basin Management*, 2015, 13(3): 315-324.
  12. Li H Y, Wang C, Ji H B, et al. Stable carbon and nitrogen isotope composition of particulate organic matter in water source of Beijing [J]. *Acta Scientiae Circumstantiae*, 2011, 31 (12): 2663-2671.
  13. Liu W C, Liu S Y, Hsu M H, et al. Water quality modeling to determine minimum instream flow for fish survival in tidal rivers [J]. *Journal of Environmental Management*, 2005, 76(4): 293-308.
  14. Maavara T, Diurr H H, Cappellen P Van. Worldwide retention of nutrient silicon by river damming: From sparse data set to global estimate [J]. *Global Biogeochemical Cycles*, 2014, 28(8): 842-855.
  15. Marx A, Dusek J, Jankovec J, et al. A review of CO<sub>2</sub> and associated carbon dynamics in headwater streams: A global perspective [J]. *Reviews of Geophysics*, 2017, 55(2): 560-585.
  16. Ni Z K, Wang S R, Zhao H C, et al. The sources of organic carbon and nitrogen of suspended particulate matter in inflow river of Erhai Lake [J]. *Research of Environmental Sciences*, 2013, 26 (3): 287-293.
  17. Nislow K H, Hudy M, Letcher B H, et al. Variation in local abundance and species richness of stream fishes in relation to dispersal barriers: implications for management and conservation [J]. *Freshwater Biology*, 2011, 56: 2135-2144.
  18. Sanchez-Vidal A, Higuera M, Martí E, et al. Riverine transport of terrestrial organic matter to the North Catalan margin, NW Mediterranean Sea [J]. *Progress in oceanography*, 2013, 118: 71-80.
  19. Tant C J, Rosemond A D, First M R. Stream nutrient enrichment has a greater effect on coarse than on fine benthic organic matter [J]. *Freshwater Science*, 2013, 32(4): 1111-1121.
  20. Tesi T, Miseroocchi S, Goni M A, et al. Organic matter origin and distribution in suspended particulate materials and surficial sediments from the western Adriatic Sea (Italy) [J]. *Estuarine, Coastal and Shelf Science*, 2007, 73(3-4): 431-446.
  21. Vannote R L, Minshall G W, Cummins K W, et al. The river continuum concept [J]. *Canadian journal of fisheries and aquatic sciences*, 1980, 37(1): 130-137.
  22. Von Schiller D, Acuña V, Graeber D, et al. Contraction, fragmentation and expansion dynamics determine nutrient availability in a Mediterranean forest stream [J]. *Aquatic Sciences*, 2011, 73(4): 485-497.
  23. Wang M L, Zhang D L, Lai J P, et al. Distribution and sources of stable organic carbon and nitrogen isotopes in suspended particulate organic matter of Poyang Lake [J]. *China Environmental Science*, 2014, 34(9): 2342-2350.
  24. Xiong S, Nilsson C. Dynamics of leaf litter accumulation and its effects on riparian vegetation: a review [J]. *The Botanical Review*, 1997, 63(3): 240-264.
  25. Yao X, Wang S, Jiao L, et al. Resolving the influence of nitrogen abundances on sediment organic matter in macrophyte-dominated lakes, using fluorescence spectroscopy [J]. *Journal of Environmental Sciences*, 2015, 27: 197-206.