

# Approaches to solving the problems of development of Irkutsk power system and improving the reliability of consumers power supply

Alexey Osak<sup>1\*</sup> and Elena Buzina<sup>1</sup>

<sup>1</sup>Melentiev Energy Systems Institute SB RAS, 664033 Lermontov str., 130, Irkutsk, Russia

**Abstract.** In the power system of the Irkutsk region since 2020, there has been a significant increase in the maximum electrical load, which amounted to more than 1.2 GW. As a result, the available reserves of power generating capacity and capacity of power grid were exhausted. In the coming years, situations of occurrence of an uncovered power shortage during periods of maximum loads are possible. It is proposed to solve the problems by increasing the flexibility of the power system, reducing the peak consumption and levelling the load schedule, including through price-dependent demand response for electric energy and power through the development of regulatory legal acts in the field of electricity supply, technological connection and improving the payment system for electricity and power, including at the level of utility and household consumers.

## 1 Introduction

By 2023, the Irkutsk power system has exhausted all available reserves, and its development on traditional principles is no longer possible. Several key aspects can be noted:

1) In the power system of the Irkutsk region in the winter of 2021-2022, a historical maximum power consumption of 9,111 MW was reached (the previous historical maximum was 8,664 MW in 1989). The maximum consumption of power in the winter of 2021-2022 is 770 MW higher than the previous maximum in 2020-2021 [1]. In the winter of 2022-2023, a new maximum level of power consumption of 9,421 MW was recorded [2], which exceeded the figure for 2022 by 310 MW. The maximum load in winter 2022-2023 is 1.08 GW higher than the maximum load in 2020-2021, i.e. 13% growth in two years.

2) In the power system of the Irkutsk region, all 110-500 kV power centers (central power substations) are "closed power centers" [3], i.e. there is no technical possibility of technological connection of consumers on general terms, therefore, technological connection of any new consumers, with the exception of certain preferential categories, is possible only on individual projects.

3) There is a sharp decrease in the reliability of power supply to consumers due to an increase in accidents in distribution power grid [4-6]. By 2022, the capacity of the 500 kV

---

\* Corresponding author: [osakalexey@mail.ru](mailto:osakalexey@mail.ru)

trunk grids, in particular the 500 kV Bratsk – Irkutsk power transmission, has been exhausted [1, 7].

## **2 Causes of problems and features of the power system**

Therefore, solving these problems in the traditional way is impossible; a revision of approaches is required, which will solve many problems using available sources of financing for the industry. The main causes of problems:

1) A significant share of electric heating (severe sharply continental climate, lack of gasification and poor coverage of district heating in areas of low-rise housing). Electric heating is characterized by an extremely uneven schedule of electricity consumption throughout the year, which generally correlates with the ambient temperature (the lower the temperature, the higher the power consumption). At the same time, the duration of peak consumption usually does not exceed 1-3 weeks per year, but a violation of heating during this period can pose a threat to the life and health of the population, can cause significant material damage.

It is necessary to develop methods for forecasting peak consumption not only on the scale of the entire regional energy system, but also at the level of smaller districts, because weather conditions in different districts in the Irkutsk region are different (area: 767,900 km<sup>2</sup>). At the level of the overall balance of the power system, the average daily temperatures are quite justifiably used [8]. But when taking into account the temperature factor in determining the possible maximum load of specific consumers or groups of consumers, it is incorrect to focus only on data on average daily outdoor temperatures corresponding to the temperature of the coldest five-day period with a security of 0.92 [9]. According to the current building codes, the temperature of the coldest five-day security of 0.92 is used as the calculated temperature [10], but it is used to normalize the energy efficiency of buildings, and not to normalize their thermal inertia. To accurately account for the load on electric heating, a correct choice of the averaging period, depending on the thermal inertia of buildings, is necessary. It is not uncommon for buildings with electric heating to be usually low-inertia (or even non-inertia). Preliminary analysis of the data shows that the average hourly ambient temperature has a greater correlation with the level of load of household consumers than the average daily temperature values.

2) Low power tariffs for the population, which makes electric heating the most cost-effective method of heating, leads to the unprofitability of many measures to improve the energy efficiency of buildings and premises. In itself, this phenomenon is not bad, because it increases the well-being of the population without special financial costs (and vice versa, an increase in energy efficiency requirements will bring down the level of well-being of the population, or will require significant budget subsidies for energy efficiency programs).

3) Significant internal migration processes in the Irkutsk region; housing and communal services are actively developing near Irkutsk, which leads to a noticeable increase in electricity consumption in the southern part of the power system (which, both initially during the formation of the power system, and now is energy deficient).

4) The appearance of "white" and "gray" cryptocurrency mining with a large value of powers consumption. Tight deadlines for commissioning of data centers, which are less than the deadlines for commissioning of any other types of production.

5) There is an extremely uneven level of use of the maximum connected power. At large aluminium plants, the average annual capacity is close enough to the maximum actual load and the maximum connected capacity. For small objects with electric heating, the average annual power is significantly lower than the maximum actual load and the maximum connected power. The actual load of the "miners" is close to the maximum connected

capacity, and the periods of "downtime" are quite difficult to predict (equipment breakdowns or external events in the "cryptocurrency markets").

As a result, the biggest problems in the power system of the Irkutsk region are in the field of distribution grids and electricity supply to municipal consumers. At the same time, we traditionally have an extremely low level of automation in grids of 10 kV and below.

### 3 Analysis of load and peak consumption schedules

Let us analyse the load graphs, estimating the magnitude of the daily fluctuations in power consumption and peak consumption.

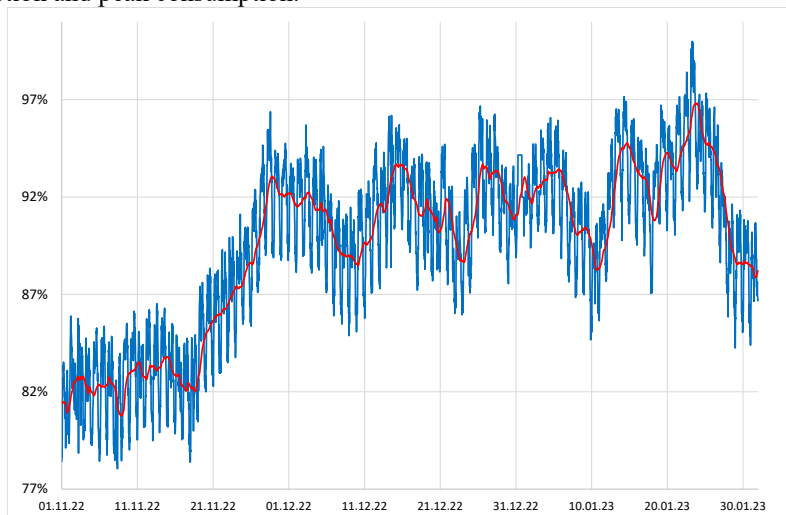

**Fig. 1.** Power load graph for the period from 01.11.22 to 31.01.23 (the coldest period of 2022/23).

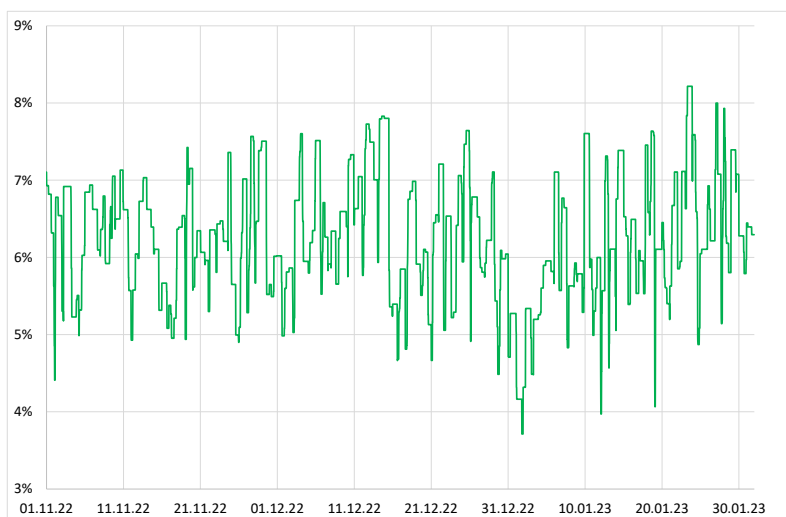

**Fig. 2.** Average daily deviation of load maxima and minima in the coldest period of 2022/23.

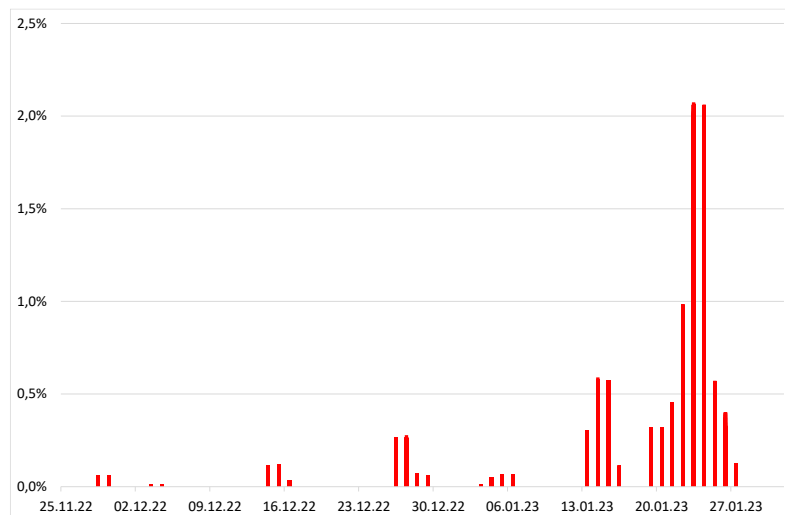

**Fig. 3.** The period and value of limiting the consumption of the power system by up to 5% of the actual maximum (by up to 460 MW), which will require limiting the power consumption to 2.1%.

Analysis of the actual load schedule for 2020-2023 shows that problems with power shortage and lack of capacity of electric grids arise only for a short period of emergency repairs and maximum load, which is 2-5 weeks a year. Accordingly, automatic limitation of the load level (including price-dependent) during such periods will avoid excessive construction of power grids and power plant. To do this, it is proposed to amend the legislation and regulatory legal acts.

## 4 The legal side of electricity supply and proposals for their reform

It should be noted the general features of technological connection (TC) to electric grids [11] and contractual relations for energy supply:

1) The connected electric power determined in applications for TC, in technical specifications (TS) for TC and power supply contracts is the maximum permissible value of the power consumed simultaneously.

2) The connected capacity does not either characterize the average daily, average monthly, or average annual capacity, since these indicators are not the subject of contractual relations at all. For example, if a certain consumer on average consumes conditionally 2-3 kW of power, but once a year for 15 minutes he needs 50 kW at once for some purposes, then he must conclude an electricity supply contract for these 50 kW (even with a small margin), while the order of connection of systematically and episodically demanded power is the same.

Therefore, the need for the actual capacity of electric grids does not follow from the contracts for electricity supply, taking into account the factor of unevenness and non-simultaneous consumption. Statistical information on uneven and non-simultaneous consumption reflects the past, but is not an indication of the future, so these factors can only serve as estimated characteristics. And the methodological guidelines [12] lead to an underestimation of the capacity of electric grids, as a result, the existing regulatory framework ensures the functioning and development of the electric grid complex either with a minimum margin of capacity (in maximum load modes), or even with insufficient capacity to ensure that consumers are provided with maximum capacity in accordance with contracts.

3) The current categories of reliability of power supply specified in clause 14.1 [11], in fact, characterize only the circuit of electrical connections, but does not characterize the actual reliability of power supply, nor the real needs of consumers in terms of quality and reliability of power supply. When determining reliability categories, neither real failure statistics, nor climatic factors, nor the length of power transmission lines, nor a host of other factors that really affect the reliability of power supply are taken into account. In conditions of strict regulation of the transmission and distribution of electricity, the incompleteness of reliability categorization plays a clearly negative role, especially for distribution grids.

It should be noted that the current practice of "social norms" [13] of electricity consumption is essentially discriminatory, because on the one hand it creates a radical inequality of people depending on the place of residence, the presence/absence of district heating and the availability of gasification of the residential sector, and on the other hand it changes the "rules of the game" (capital expenditures of the population for the construction and purchase of individual housing were made before the appearance of "social norms"). It is important to note that if, due to the growth of tariffs, the introduction of "social norms", a significant reduction in electricity consumption by the utility sector is achieved, this will lead to a significant increase in unit operating costs (per 1 kWh), since an increase in the average annual load of grids and power plants increases their efficiency.

It is advisable to reform the power industry in terms of organizational, legal, contractual and technical aspects of technological connection and power supply to consumers.

At the same time, a modern approach to ensuring the flexibility of power systems [14-16], including a modern approach to electricity demand response [17] are a possible way to solve the accumulated problems [18]. And if at the level of large consumers, emergency automation with the function of switching off the load has been operating effectively for many years [19-21], and in recent years the demand response system has been successfully functioning [22], then at the level of municipal consumers in the Russian Federation, these tasks, in fact, have not yet begun to be solved.

The modern level of digitalization ("government services", "personal cabinets", electronic document management) allows us to implement more complex and at the same time flexible contractual relations with household consumers than are available today. Instead of two fixed contractual positions (connected capacity and reliability category) and one variable (monthly volume of electricity consumed), it would be possible to introduce much more indicators. First of all, these are the maximum and average capacities for different periods (parts of the day, day, week, month, year), and based on this, implement more flexible pricing.

## **5 Technical implementation**

If there are appropriate regulatory and legal grounds, there are no problems in creating a relatively inexpensive device that combines the functions of a "smart meter" and a load disconnection/limitation device that allows you to implement all this complex and flexible system of prospective billing. And also, allowing one input (single- or three-phase) to be distributed to several outgoing lines with different modes of their operation, including with the possibility of limiting the load of part of the lines, both under contractual conditions and according to the commands of regime and emergency automation, including to realize the possibility of demand response at the household level.

It is proposed to implement an automatic load control system for consumers power, including located both at the level of power centres and at the input power devices of end consumers. Such a system should solve the following tasks:

- at the level of the power center:
  - retransmission to end users of up-to-date pricing information (for flexible tariffs), both on the basis of system-wide data and on local parameters;

- the functions of automation of voltage reduction limitation and automation of equipment overload limitation with the transmission of commands (via any available communication channels) load limitation to consumers, and if the required reduction volume is not realized, the shutdown of individual feeders as a whole;
- at the level of the input power device of the end power customers:
  - the functions of flexible changing of power consumed, and thereby realize the possibility of price-dependent reduction of power consumption;
  - the function of receiving a command to limit the amount of power load from the power center or dispatch center;
  - the functions of automatic switching on/off of individual lines (for providing power to individual electric receivers) depending on tariff criteria or in the presence/absence of a load limitation command.

From a technical point of view, there are no significant problems to create a relatively inexpensive "smart meter" that allows implementing the proposed system, but changes to regulatory legal acts are required.

Earlier, in the papers [23, 24], the authors considered a load disconnection system in distribution grids of 35 kV and below, for which it is proposed to use any existing communication channels [21], including cellular, Fig. 4. The device installed in the power center sends a shutdown command, simultaneously controlling the load reset in the feeder head. If the required amount of unloading has not occurred in the required time, then you can turn off the feeder entirely. Thus, the task of disconnecting the load will be solved in any case.

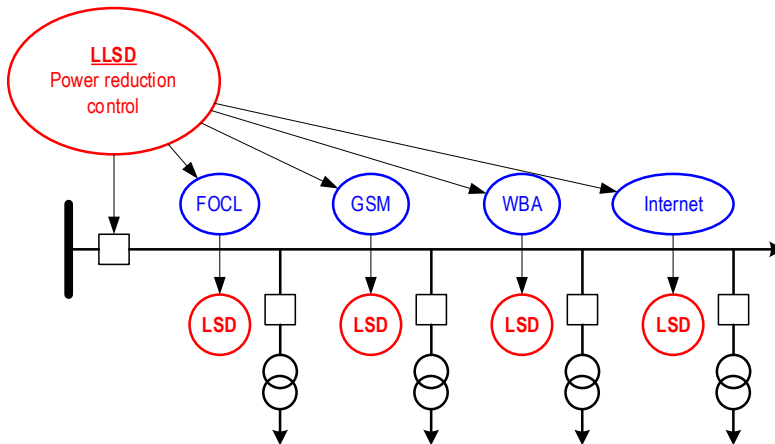

**Fig. 4.** Technology for disconnecting the load from emergency control devices in 0.4 – 35 kV grids without the use of expensive duplicated communication channels.

## 6 Conclusion

By 2023, the energy system of the Irkutsk region has exhausted all available reserves and reserves, and its development on traditional principles is no longer possible. The problem is reflected in the Scheme and program of development of electric power systems in Russia for 2023-2028 [7]. Solving the problem by traditional methods (construction of new power lines and substations) requires large capital investments, and therefore inefficient.

It is proposed to solve the problems by increasing the flexibility of the power system, reducing the peak consumption and levelling the load schedule, including through price-dependent demand response for electric energy and power due to the development of legal

acts in the field of power supply, technological connection and improving the payment system for electricity and power, including at the level of utility consumers. On the technical side, in order to implement this approach, it is necessary to create an automatic load control system for utility consumers, located both at the level of power supply centers and at the input devices of end consumers with the possibility of limiting the load of consumers, both under contractual conditions and according to the commands of regime and emergency automation upon overload of power lines, transformers, prevention of violations of stability, unacceptable voltage reduction.

## References

1. Mayakov D.V., Kornilov V.N. Irkutsk – the capital of mining: new challenges for the power system // Bigpower Daily. 16.12.2022.  
URL: <https://www.bigpowernews.ru/interview/document106777.phtml>
2. Power consumption in the power system of the Irkutsk region has reached a new record value. The website of JSC "SO UPS".  
URL: <https://www.so-ups.ru/odu-siberia/news/odu-siberia-news-view/news/20772/>
3. Information about the availability of power available for technological connection. The website of JSC "IESK".  
URL: <https://www.irk-esk.ru/customers/attachment/availability>
4. The volume of undelivered power energy as a result of emergency shutdowns. The website of JSC "IESK".  
URL: [https://irk-esk.ru/customers/transmission/blackouts/accidents\\_values](https://irk-esk.ru/customers/transmission/blackouts/accidents_values)
5. Residents of the Irkutsk region complained of power outages. Information site of the Irkutsk region.  
URL: <https://www.irk.ru/news/20221213/mining/>
6. Decree of the Governor of the Irkutsk Region dated 04/28/2022 No. 71-ug "On approval of the scheme and program for the development of the electric power industry of the Irkutsk region for 2023-2027".  
URL: <https://www.ogirk.ru/pravo/archives/law/330860>
7. Order of the Ministry of Energy of the Russian Federation No. 108 dated 02/28/2023 "On approval of the scheme and program for the development of electric power systems of Russia for 2023-2028".  
URL: <https://minenergo.gov.ru/node/24125>
8. Requirements for forecasting consumption and forming balances of electric energy and power system capacity for a calendar year and periods within a year, approved by Order of the Ministry of Energy of the Russian Federation dated February 11, 2019 No. 91.  
URL: <https://www.so-ups.ru/fileadmin/files/laws/orders/pr91-110219me.pdf>
9. SP 131.13330.2012 "Construction climatology. Updated version of SNiP 23-01-99", approved by the Order of the Ministry of Regional Development of Russia dated 30.06.2012 No. 275.  
URL: <https://www.dokipedia.ru/document/5338835>
10. SNiP 23-02-2003 Thermal protection of buildings.  
URL: <https://www.dokipedia.ru/document/1724192>
11. Rules for Technological Connection of Power Receiving devices of Electric energy Consumers, electric energy production facilities, as well as power grid facilities Belonging to grid organizations and Other Persons to power grids, approved by Decree

- of the Government of the Russian Federation No. 861 of 12/27/2004.  
URL: <https://docs.cntd.ru/document/901919551>
12. Methodological guidelines for determining the degree of loading of power grid facilities introduced after construction, as well as for determining and applying the coefficients of combining the maximum consumption of electric energy (capacity) when determining the degree of loading of such facilities, approved by Order of the Ministry of Energy of the Russian Federation No. 250 dated May 6, 2014.  
URL: <https://docs.cntd.ru/document/499099225>
  13. Regulation on the establishment and application of the social norm of consumption of electric energy (capacity), approved by the Decree of the Government of the Russian Federation dated July 22, 2013 No. 614.  
URL: <https://base.garant.ru/70422296/>
  14. Status of Power System Transformation 2018: Advanced Power Plant Flexibility. IEA. Paris. 2018. DOI:10.1787/9789264302006-en.
  15. N. Voropai, C. Rehtanz, Flexibility and resiliency of electric power systems: Analysis of definitions and content, *EPJ Web of Conferences*. EDP Sciences, **217**, pp. 01018 (2019). DOI: 10.1051/epjconf/201921701018.
  16. N.I. Voropay, Prospects and Problems of Electric Power System Transformations, *Elektrichestvo*, No. 7, 12-21 (2020). DOI: 10.24160/0013-5380-2020-7-12-21.
  17. About the technology of price-dependent consumption. Website of JSC "SO UES".  
URL: <https://www.so-ups.ru/?id=dr>.
  18. A. Osak, E. Buzina, Flexibility and security of power systems, methods of analysis, and criteria for their evaluation in the conditions of digital transformation of the power industry, *AIP Conference Proceedings*, **2552**, 040008 (2023).  
DOI: 10.1063/5.0114361.
  19. GOST R 55105. Unified energy system and isolated power systems. Operational dispatch control. Automatic emergency control of power systems modes. Emergency automation of power systems. Norms and requirements.  
URL: <https://meganorm.ru/Data2/1/4293724/4293724536.pdf>
  20. N.I. Voropai, D.N. Efimov, et. al., Distributed adaptive load shedding scheme to maintain transient stability and prevent overload in power systems, Proc. of 9th IFAC Symp. on Control of Power and Energy Systems, New Delhi, India, December 9-11, 2015, IFAC-PapersOnLine Volume 48, Issue 30, 2015, Pages 554–559.  
DOI: 10.1016/j.ifacol.2015.12.438
  21. N.I. Voropai, D.N. Efimov, et. al. Adaptive algorithms for automatic distributed load shedding, *Electrical stations*, No. 11. 27-35 (2016).  
URL: <http://elst.energy-journals.ru/index.php/elst/article/view/610>
  22. Reviews on the functioning of the mechanism of price-dependent reduction of consumption for 2022. Website of JSC "SO UES".  
URL: <https://www.so-ups.ru/functioning/markets/dr/reviews/2022/>
  23. A.B. Osak, D.A. Panasetsky, A.V. Domyshev, E.Ya. Buzina, Centralizer emergency control system taking into account distributed generation and consumer characteristics, Reports of the international conference "Relay protection and automation of power systems – 2017", St. Petersburg, April 25-28, 2017.  
URL: <https://elibrary.ru/zqjwur>
  24. A.B. Osak, D.A. Panasetsky, E.Ya. Buzina, Consumer operation mode-wise intelligent emergency control, Proceedings of Irkutsk State Technical University, **9** (128), 173-185 (2017). DOI: 10.21285/1814-3520-2017-9-173-184