

# Applicable design of multi-functional cascade heat pump system for an office building

Beom-Jun Kim<sup>1</sup>, Hye-Jin Cho<sup>1</sup>, Soo-Jin Lee<sup>1</sup>, Taek-Don Kwon<sup>1</sup>, and Jae-Weon Jeong<sup>1\*</sup>

<sup>1</sup>Department of Architectural Engineering, College of Engineering, Hanyang University, Seoul, Republic of Korea

**Abstract.** When the cascade heat pump system is applied as a multi-functional system that can be used not only for hot water supply but also for air-conditioning of buildings, the low-stage cycle is responsible for indoor heating and cooling thermal load, and the high-stage cycle is responsible for hot water supply by raising the refrigerant temperature. Unlike the existing cascade heat pump system designed with only one operation mode for hot water supply, the multi-functional cascade heat pump system should be considered with various parameters. This study was proposed a design sequence of the cascade heat pump system for building application, and the energy-saving performance was compared with the existing cascade heat pump system for hot water supply and parallel heat pump system for air-conditioning. The office building was set for the study, and the thermal load of the building was calculated in the TRNSYS program. The systems were calculated using the thermodynamic equation and the model built into EnergyPlus. As a result, the system can be affected by the outdoor air heat source. The energy-saving performance was 25% for the multi-functional cascade heat pump system compared to the simultaneous use of the existing system.

## 1 Introduction

The main purpose of the existing cascade heat pump system is to produce hot water with low energy consumption in the cold region [1,2]. As shown in Figure 1(a), the system operates with one goal temperature. This system only needs to consider the fluctuations of the heat-source of the outside air. However, when the system is applied for multi-functional operation of the building, the more purpose of the system is needed (e.g., indoor heating and cooling, hot water supply) [3]. As shown in Figure 1(b), the goal temperatures that change according to the operation mode are different. This means that when designing and optimizing the multi-functional cascade heat pump system, it is necessary to consider the parameters that vary by operation mode.

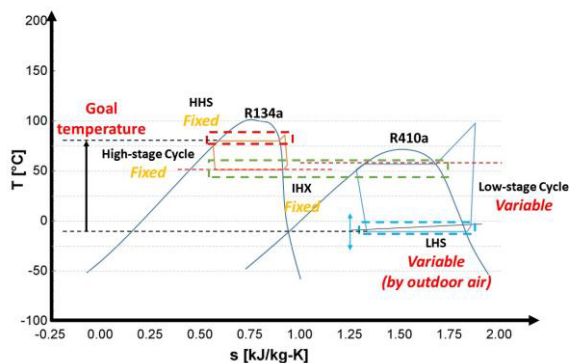

(a) Existing cascade heat pump

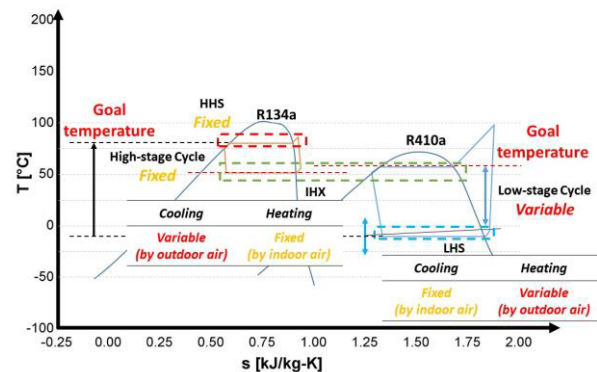

(b) Multi-functional cascade heat pump

**Fig. 1.** T-s graph of the cascade heat pump system for heat source

This study was proposed a design sequence of the cascade heat pump system for building application, and the energy-saving performance was compared with the existing cascade heat pump system for hot water supply and parallel heat pump system for indoor air-conditioning. The office building was set for the study, and the thermal load of the building was calculated in the commercial thermal load calculating program. The proposed and existing systems were calculated using the thermodynamic equation.

## 2 System overview

\* Corresponding author: [jjwarc@hanyang.ac.kr](mailto:jjwarc@hanyang.ac.kr)

## 2.1 Multi-functional cascade heat pump

Figure 2 shows a cascade heat pump system that satisfies all the functions of cooling, heating, and hot water based on an air heat source [4]. An Indoor unit for air conditioning is installed on the zone side, and the other heat pump is connected to an interactive heat exchanger to supply heat to the hot water tank. In summer, the low heat cycle is operated in cooling mode, and the heat after the compressor is supplied to the IHX for hot water supply, and the remaining heat is released through the outdoor unit. In winter, the low heat cycle operates in heating mode and supplies heat after the compressor to the indoor and hot water heat exchanger at the same time. The high heat cycle for hot water is always operated in one direction only.

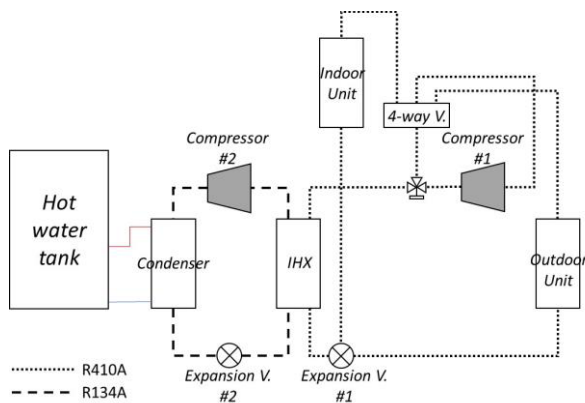

Fig. 2. Multi-functional cascade heat pump system.

## 2.2 Existing cascade heat pump for hot water

Because the existing cascade heat pump for hot water supply is for hot water supply, both heat pumps operate only in the one-way cycle. The other heat pump system was set up as a parallel system for indoor heating and cooling. The heat pump systems are shown in Figure 3.

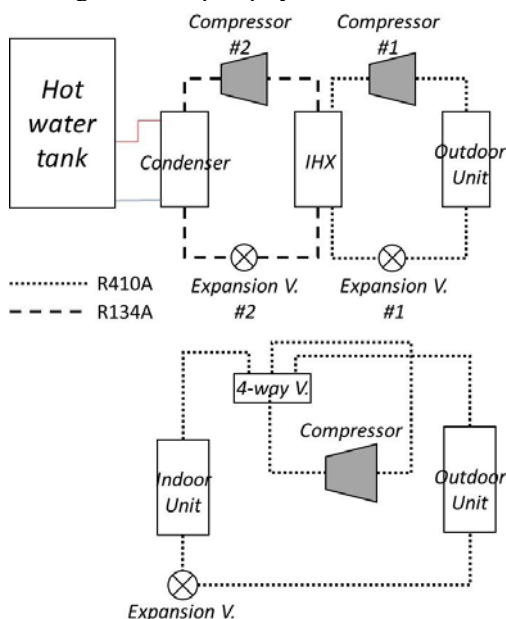

Fig. 3. Cascade heat pump system for hot water and parallel heat pump system for indoor air-conditioning.

## 3 Design sequence

### 3.1 Input parameters

The first step in the design sequence of the multi-functional cascade heat pump system is the determination of input parameters. The input parameters are zone thermal load, hot water supply load, coefficient of performance (COP) of commercial heat pump, and temperature and humidity of outdoor, indoor, and supply air (Table 1). The above input parameters are set to the input values according to the operation mode for each season.

Table 1. Input parameters for multi-functional cascade heat pump system.

Parameter	Name
$\dot{Q}_{zone}$	Zone thermal load
$\dot{Q}_{dhw}$	Hot water load for building
COP	Coefficient of performance
$T_{oa}$	Temperature of outdoor air
$RH_{oa}$	Relative humidity of outdoor air
$T_{zone}$	Temperature of zone air
$RH_{zone}$	Relative humidity of zone air
$T_{sa}$	Temperature of supply air
$RH_{sa}$	Relative humidity of supply air

### 3.2 Hot water size

Hot water supply load is calculated by determining the amount of hot water supplied per hour for each appliance according to the type of building, and the amount of hot water [ref]. The hourly maximum hot water supply is calculated by multiplying the hot water supply for each appliance by the number of appliances. The hot water supply load is calculated by multiplying the time maximum hot water supply by the temperature difference between hot water and water supply.

$$Q_h = P \sum (q_j \times n) \quad (1)$$

$$\dot{m}_{water} = Q_h / 3600 \quad (2)$$

$$H = 1.163 Q_h (T_{hw} - T_{tap}) \quad (3)$$

### 3.3 Heat pump size

To calculate the heat pump capacity, determine the zone thermal load using the TRNSYS program. Based on the COP of the commercial heat pump, the amount of work of the compressor based on the heat balance and the amount to be discharged from the condenser are calculated.

$$\dot{Q}_{evap.i} = \dot{Q}_{zone} \quad (4)$$

$$\dot{W}_{comp.i} = \dot{Q}_{evap.i} / COP \quad (5)$$

$$\dot{Q}_{cond.i} = \dot{Q}_{evap.i} + \dot{W}_{comp.i} \quad (6)$$

After calculating the required air volume in the indoor unit and outdoor unit through the heat transfer equation,

the temperature of the refrigerant required in each unit is calculated

$$\dot{m}_{indoor} = \dot{Q}_{evap,i} / (c p_{sa} \times (T_{sa} - T_{zone})) \quad (7)$$

$$\dot{m}_{outdoor} = \dot{Q}_{cond,i} / (c p_{oa} \times (T_{oa,out} - T_{oa})) \quad (8)$$

$$T_{evap,L} = T_{zone} - \dot{Q}_{evap,i} / (\epsilon_{hx} \times \dot{m}_{indoor} \times c p_{zone}) \quad (9)$$

$$T_{cond,L} = T_{oa} + \dot{Q}_{cond,i} / (\epsilon_{hx} \times \dot{m}_{outdoor} \times c p_{oa}) \quad (10)$$

The temperature difference between the low cycle and the high cycle was assumed to be 5 degrees.

$$T_{evap,H} = T_{cond,L} + 5 \quad (11)$$

$$T_{cond,H} = T_{tap} + \dot{Q}_{dhw} / (\epsilon_{hx} \times \dot{m}_{water} \times c p_{water}) \quad (12)$$

### 3.4 Thermodynamic equation

The amount of compressor work required in the heat pump is calculated using a thermodynamic equation. The above equations are expressed based on the cooling mode, and in the case of the heating mode, the equation positions of evaporation and condenser are exchanged for calculation.

$$\dot{m}_{ref,L} = \dot{Q}_{evap,i} / (h_{evap,L,o} - h_{evap,L,i}) \quad (13)$$

$$W_{comp,L} = \dot{m}_{ref,L} (h_{comp,L,o} - h_{comp,L,i}) \quad (14)$$

$$\dot{Q}_{cond,L} = \dot{m}_{ref,L} (h_{cond,L,i} - h_{cond,L,o}) \quad (15)$$

$$\dot{m}_{ref,H} = \dot{Q}_{dhw} / (h_{cond,H,i} - h_{cond,H,o}) \quad (16)$$

$$W_{comp,H} = \dot{m}_{ref,H} (h_{comp,H,o} - h_{comp,H,i}) \quad (17)$$

$$\dot{Q}_{evap,H} = \dot{m}_{ref,H} (h_{evap,H,i} - h_{evap,H,o}) \quad (18)$$

$$\dot{Q}_{evap,dhw,req} = \dot{Q}_{evap,H} / \epsilon_{hx} \quad (19)$$

$$\dot{Q}_{cond,remain} = \dot{Q}_{cond,L} - \dot{Q}_{evap,dhw,req} \quad (20)$$

## 4 simulation overview

### 4.1 Building information

An office building with three-story located in Seoul was assumed in this study. A 100 m<sup>2</sup> of floor area was determined. The building information is shown in Table 2 [5]. The hot water supply load, indoor occupants, and hot water supply schedule were simulated based on ASHRAE Standard 90.1 and local hot water supply load design criteria [6].

**Table 2.** Information of model office building.

Category	Component	values
Floor area		100
Number of floors		3
Occupants		15
Heat gain	People [W/person]	130
	Equipment [W/m <sup>2</sup> ]	7
	Lights [W/m <sup>2</sup> ]	12.5
U-value	Outdoor wall [W/m <sup>2</sup> K]	0.240
	Floor [W/m <sup>2</sup> K]	0.276
	Roof [W/m <sup>2</sup> K]	0.141
	Window [W/m <sup>2</sup> K]	1.4

### 4.2 Input values

The input values based on the Table 1 are described in Table 3. For the impact analysis, the simulation was

conducted by dividing it into 5 levels from min value to max value.

**Table 3.** Input values of the input parameters.

Parameter	Min	Average	Max	
$\dot{Q}_{zone}$	3.57	10.71	17.85	
$\dot{Q}_{dhw}$	1.3	3.9	6.5	
$T_{oa}$	Cooling	20	30	40
	Heating	-10	0	10
$T_{zone}$	Cooling	22	26	30
	Heating	16	20	24

## 5 Result and discussion

### 5.1 Impact analysis

As a result of the impact analysis, the indoor load and outdoor air had a great influence on the system capacity estimation. Since the indoor load is directly related to the capacity of the low cycle heat pump, the effect was large, and the change in the hot water supply load did not have a significant effect on the high cycle heat pump compared to the low cycle. Since the change in outdoor temperature directly affects the heat source or heat sink of the heat pump, it has a great influence on the capacity calculation. When the capacity was calculated based on the heating mode rather than the cooling mode, the influence of the two parameters was greater.

**Table 4.** Result of the impact analysis of the simulation.

Parameter	Cooling		Heating	
	$\dot{W}_{comp,L}$	$\dot{W}_{comp,H}$	$\dot{W}_{comp,L}$	$\dot{W}_{comp,H}$
$\dot{Q}_{zone}$	0.64	0.00	2.13	0.00
$\dot{Q}_{dhw}$	0.00	0.19	0.78	0.12
$T_{oa}$	0.37	-0.21	-1.43	0.00
$T_{zone}$	0.07	0.00	-0.29	0.04

### 5.2 Energy consumption analysis

Based on the design sequence considered in this study, energy consumption was compared by simulating a multi-functional cascade heat pump, an existing cascade heat pump system, and a parallel heat pump system under the same conditions (Figure 4). As a result, the energy consumption of the multi-functional heat pump was reduced by 3.7 kWh when both heating and cooling modes were combined. It was found that this was because one system used the heat source to the maximum to supply heating and cooling and hot water supply in the zone.

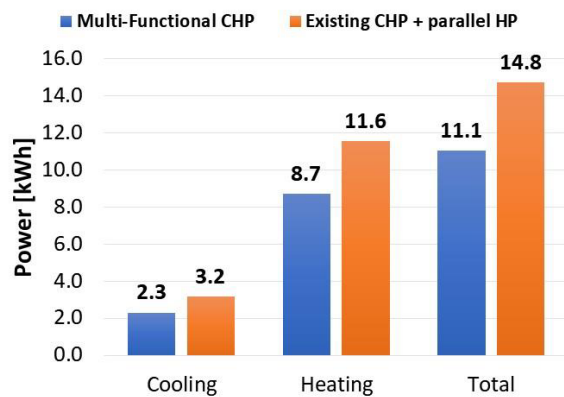

**Fig. 4.** Energy consumption analysis based on the proposed design sequence.

## 6 Conclusion

This study was proposed a design sequence of the cascade heat pump system for building application, and the energy-saving performance was compared with the existing cascade heat pump system for hot water supply and parallel heat pump system for indoor air-conditioning. The office building was set for the study, and the thermal load of the building was calculated in the commercial thermal load calculating program. The proposed and existing systems were calculated using the thermodynamic equation.

As a result of the simulation, the outdoor air temperature, and zone thermal load is most important parameters when designing the multi-functional cascade heat pump system for the office building. The energy-saving performance was 25% compared to the simultaneous use of the existing cascade heat pump system for hot water supply and the existing heating and cooling system.

For the future work, it is necessary to conduct empirical research on energy saving performance by making a test specimen to which the capacity calculation process proposed in this study is applied. Additional application analysis is necessary to evaluate for residential buildings or hotel because of the high proportion of hot water supply.

This work was partly supported by Korea Institute of Energy Technology Evaluation and Planning(KETEP) grant funded by the Korea government(MOTIE)(No. 20202020800360) and the National Research Foundation of Korea(NRF) grant funded by the Korea government(MSIT) (No. 2022R1A2B5B02001975).

## References

1. D.H. Kim, H.S. Park, *Refrigeration and Air Conditioning*, Purdue e-pubs, 1295 (2012).
2. M. Qu, Y. Fan, J. Chen, T. Li, Z. Li, H. Li, *Applied Thermal Engineering*, **110**, 835–843 (2017). doi:10.1016/j.applthermaleng.2016.08.176.
3. H.W. Jung, H. Kang, H. Chung, J.H. Ahn, Y. Kim, *International Journal of Refrigeration*, **42**, 57–68 (2014). doi:10.1016/j.ijrefrig.2014.03.004.

4. S.S. Bertsch, E.A. Groll, *International Journal of Refrigeration*, **31**, 1282–1292 (2008). doi:10.1016/j.ijrefrig.2008.01.006.
5. Korea Energy Agency, *Energy saving design standard of buildings*, Ministry of Land, Infrastructure and Transport, South Korea (2018).
6. ASHRAE. *ANSI/ASHRAE Standard 90.1–Energy Standard for Buildings Except Low-Rise Residential Buildings*, (2019).