

Artificial Coral Reef Growth Media Model Engineering from Ceramic

Ni Putu Muliawati¹, I Made Dwi Setiadi*¹, Guino Verma¹, Maya Larasati Donna Wardani¹, Geby Otivriyanti¹

¹Balai Teknologi Industri Kreatif Keramik (BTIKK), Badan Pengkajian dan Penerapan Teknologi (BPPT), Denpasar, Indonesia

Abstract. The experiment on the artificial coral reef was conducted at BTIKK using ceramic body mass code BL1. This engineering was carried out in two steps, the first step was making the design of the growth media, and the second step was testing the mass of the ceramic body and making the growth media model. The hexagonal design was used beginning from the design concept that applies geometric shapes with many sides, making it easier to arrange the formation under the sea. Aesthetically, the hexagonal shape can represent a design concept. It resulted from integration in the design of coral reef planting media with natural marine ecosystems and can produce new experiences and impressions to attract people's attention to pay more attention to the preservation of coral reefs. The assessment of fired shrinkage, water absorption, and apparent porosity on body mass for making the growth medium model was tested on 15 test pieces. The average value of fired shrinkage on 900°C temperature fired test pieces is 1.3%, the average water absorption is 19.7%, and the apparent porosity is 32.9%. Their value could be used to make artificial coral reef growth media.

1 Introduction

Indonesia is an archipelago country that consists entirely of islands. Territorial boundaries are drawn from the archipelago baselines covering land areas, interior waters, archipelago waters, and the territorial sea, including the airspace above it and the seabed and the land below the natural resources contained therein [1]. Indirectly, this condition means Indonesia has abundant natural resources potential, especially the sea. Due to its place between Indian Oceans and the Pacific Oceans, also flanked by Asia and Australian continents, the potential for natural resources exploitation by external and domestic parties is huge. As the fourth most populous country in the world [2], the population dynamics will impact marine biodiversity, especially shallow marine. Shallow marine ecosystems consist of several communities; one of them is coral reefs, which need to be preserved. Besides population activities, natural disasters such as earthquakes and tsunamis also affect to marine ecosystem especially coral reefs [3]. However, the natural factors could not be controlled, so the impact due to human dynamics is more controllable.

* Corresponding author: dwisetiadi@gmail.com

Coral reef conservation is a program that aims to restore the life of damaged coral reefs by planting artificial reefs. Artificial coral reefs have substantial positive effects on surrounding aquatic ecosystems. It can be built out of the metal framework, steel, steel-reinforced concrete, or concrete, as well as recycled plastics, ceramics, and fiberglass [4]. Ceramics are generally made from several mixtures and then go through a combustion process, brittle and durable. Artisans can use ceramics as a medium for coral reef conservation, considering the Covid-19 pandemic has an impact on the economic sector, especially MSMEs (Micro, Small, and Medium Enterprises) ceramic artisans. This paper was created as an initial study to develop ceramics as artificial coral reefs. In addition, it aims to empower MSMEs to help the government to conserve coral reefs.

2 Material and Method

Artificial reefs are a module to grow colonies of coral, can use local clay or earthenware. It can also be fired up to a maximum temperature of 1150oC from stoneware clay without a touch of glaze. Studies on coral recruitment frequently employ unglazed ceramic settlement tiles [5]. The surface of the artificial coral reef is not slippery by a layer of glazes so that coral animal seeds can live and thrive on this reef medium. It can be a growth medium as long as the surface is porous. This study uses a combination of materials commonly used in ceramics. The clay body mass used is code BL1. It was made from a mixture of quartz, kaolin, feldspar, and other materials. The processing of this clay used a ball mill with a production capacity of 350 kg. This research was divided into two steps. The first step was making an artificial reefs design, the second step was testing the mass of the ceramic body and making a model.

2.1 Design

This study used the semiotics method to create the design. Semiotics could be applied to various types of research, such as mass communication, visual communication, writing, and others. It has great potential in analyzing and interpreting data like text, music, photos, videos, and others [6]. Some literature and image were compiled and studied. They were analyzed by semiotics, and the outcome is design signs. It will be used to design the artificial coral reefs model.

a. Sturdy

Heavy, solid, thick designs composed collectively are required to protect the substrate from ocean currents. Composed collectively means the placement of the substrate must be related to others, so the position is more solid and rigid. The substrate thickness is necessary to prevent the rate of erosion caused by some objects carried by ocean currents. It will be looked optimal when the wall thickness is 2-5 cm, and the weight is 5-10 kg. The join system between the substrates should be tight but not rigid because it can damage the substrate structure. The join system using ropes can be applied because it is more flexible and can respond to the movement of ocean currents well.

b. Hollow

Apart from being a medium for growing reefs, the substrate is expected to be a hiding place for small fish from ocean currents and predators. The design's success is an interaction of organic beings with artificial models. The design was made by providing a small room and some circular holes.

c. Dynamic

Dynamic means a design composition is not monotonous does not move, and does not stagnate. The concept of geometric shapes could be applied by considering their interactions with the surrounding environment. Four or six sides' designs could be applied because they are easier to make a join system.

2.2 Testing & Modeling

2.2.1 Testing

Ceramic clay code BL1 was analyzed by testing fired shrinkage, water absorption, and apparent porosity. The steps to make the test piece to fulfill the analysis is by making a test piece measuring 10 x 2 x 1.5 cm. The test pieces were made of 15 pieces using the following tools: 1) clay, 2) molds of test bricks, 3) string strings, 4) alphabet stamps. Then they dried for four days at room temperature and fired using a Nabertherm electric furnace. The firing process takes 6 hours from a furnace temperature of 29°C to a temperature of 900°C. Fired shrinkage was measured to determine how many clay percentages would be used. It will help estimate the size of the model according to the design. After the sample had dried (controlled by weighing, the difference in weight was less than 0.5 g for two days), the distance of the line marks was determined with a micrometer precisely to 0.1 mm (p cm). The dry shrinkage (DS) is calculated based on the formula [8]:

$$DS = \left(\frac{10 - p}{10} \right) \times 100\% \quad (1)$$

The measured samples by the distance between the marking are p cm. They were burned in a furnace to the final temperature to determine the fired shrinkage. After the fired process was completed, it was cooled in the furnace. The distance of the line marks was determined with a micrometer to 0.1 mm (p1 cm) [8]. Calculation of fired shrinkage (FS) formulated as below:

$$FS = \left(\frac{p - p1}{p} \right) \times 100\% \quad (2)$$

Moreover, the total shrinkage (TS) formulated as below [8]:

$$TS = \left(\frac{9,9 - p1}{9,9} \right) \times 100\% \quad (3)$$

The steps for measuring water absorption are post-fired samples are dried in an oven at a 105–110°C temperature, so the weight remains constant. Then they were cooled in a desiccator and determined the dry weight (D grams) with an accuracy of 0.1 g. Then soaked in water, take up and wipe with a dried cloth. The sample has weighed with a balance with an accuracy of 0.1 g (W gram) immediately [8], then the water infiltration was determined by the formula:

$$WA = \left(\frac{W - D}{W} \right) \times 100\% \quad (4)$$

Determination of the apparent porosity value was by weighing the fired weight after cooling (B) with an accuracy of 0.1 grams, the saturated weight measured when sinking at the bottom of a container with 1.000 ml of water (J), and the floating weight in water is symbolized (M), determined by the formula [8] :

$$PP = \left(\frac{J - B}{J - M} \right) \times 100\% \quad (5)$$

2.2.2 Modeling

Models or substrates were made by the hand-building technique using an electrical wheel. Clay was wedged to minimize air bubbles and make it easier to build. It could be added to some water slowly by hand. Then it dried at room temperature for 3-4 days and then fired in a gas furnace to 900°C temperature for 6 hours.



Fig.1. Wedging process (left), hand-building technique (center), and firing process (right).

3 Result & Discussion

3.1 Design Engineering

3.1.1 Using Ceramic

According to [7], showed that artificial coral reefs made of ceramics were non-toxic and pH neutral. Ceramics are made from several mixtures and then are brittle and durable through a fired process. It could be built in various designs, methods, and local clay materials.

3.1.2 Hexagonal Shape

Inspired by [7], the hexagonal design was used beginning from the design concept that applies geometric shapes with many sides, making it easier to arrange the formation under the sea. Aesthetically, the hexagonal shape can represent a design concept resulting from integration in the design of coral reef planting media with natural marine ecosystems and can produce new experiences and impressions to attract people's attention to pay more attention to the preservation of coral reefs.

3.1.3 Have a Coral Reef Seedling Development Space

This growth space is an area that can facilitate the need for growth space for coral reef seedlings. In addition, it has to be able to protect coral reef seedlings from the ocean currents during their growth period. The protection is applied by designing walls around the coral reef growth space.

3.1.4 Design Formation & Join System

Model or substrate placement under the sea has to be collective and mutually bound to each other. The purpose is to strengthen the position of the substrate and create new coral reef communities. The formation can be very varied and not monotonous with a hexagonal base shape. The hexagonal shape allows the composition of substrate composition to look like a honeycomb in the ocean. The arrangement between the substrates is to bring together the sides of each substrate. A rope could use as a joint system between substrates because it is more flexible and has longer durability in the sea. The recommended type of rope is a manila rope, plastic rope, or cable ties.

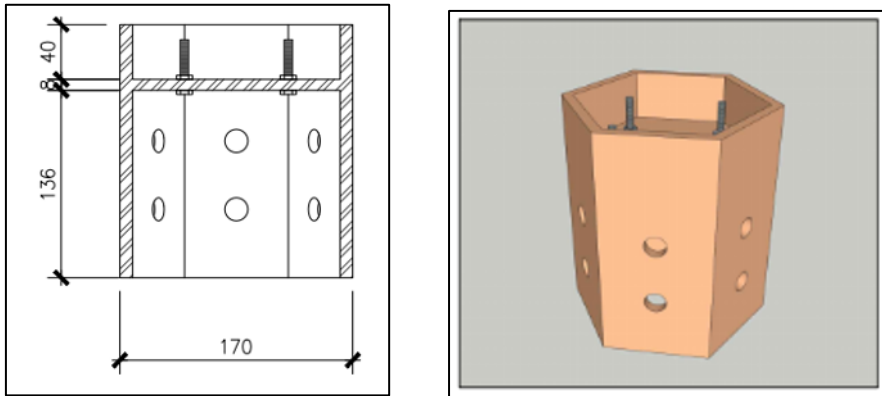

Fig. 2. Section view design (left) scale 1:5 and perspective view design (right).

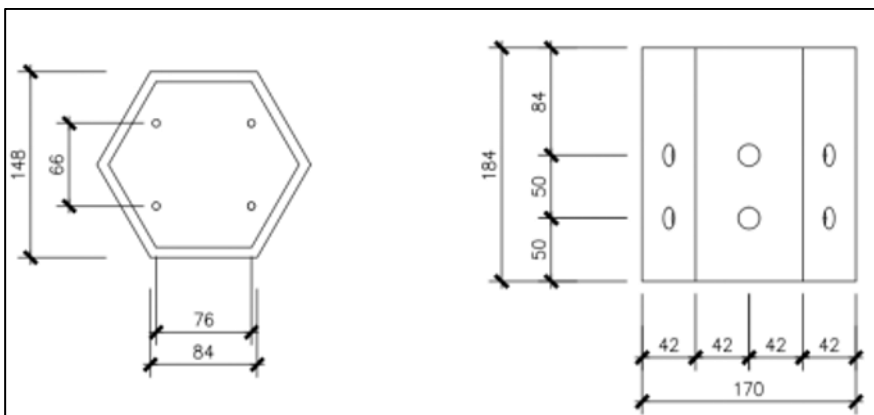

Fig. 3. Upper view design (left) and front view design (right) scale 1:5.

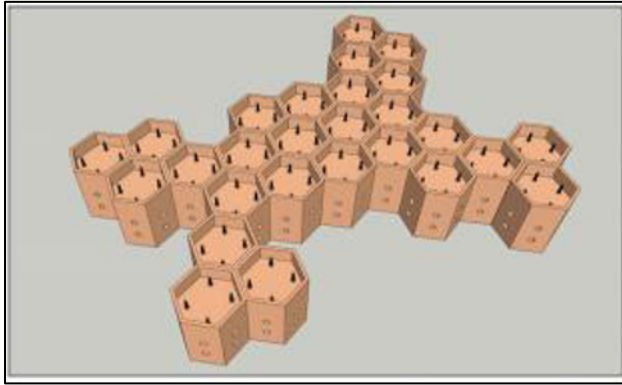

Fig. 4. Formation and join system design.

3.2 Ceramic Physical Properties

Ceramics' physical properties values were obtained by measuring the length and weight of the test pieces. The result was calculated using the equation. Based on the calculation results, the average value of dry shrinkage is 5.3%, fired shrinkage is 1.3%, and total shrinkage is 6.5%. Meanwhile, the average water absorption value is 19.7%, and the apparent porosity is 32.9%.

The shrinkage value would be compared with how much water absorption is after burning in ceramics. If the sintering temperature is higher, the shrinkage value will follow. It is due to the mass transport (diffusion) of atoms between particles that causes the formation of grains and the elimination of pores. The diffusion mechanism is the main cause of shrinkage during sintering, a volume with grain diffusion being the dominant mechanism in the sintering process of ceramic materials [9]. Shrinkage values could be used to estimate the use of materials when making a model or substrate. Water absorption shows how much fluid can enter through the ceramic pores. These pores can serve as a place for the deposition of CaCO_3 from the secretions of the coral reef itself and other marine organisms such as green algae or red algae. The persistence of coral reefs depends on CaCO_3 balance, deposition, and removal throughout the reef. In addition, other organisms such as calcareous green algae and red algae also contribute their hard parts to the coral reefs [10].



Fig. 5. Test pieces of ceramic, fired at 900°C temperature.



Fig. 6. Front view of the model.



Fig. 7. Upper view of the model.

Table 1. Calculation of physical properties.

Sample Code	Lenght (cm)			Weight (gr)			Shrinkage (%)			Water Absorption (%)	Apparent Porosity (%)
	Wet	Dried	Firing	Firing	Saturated	Floating	Dried	Firing	Total		
1	9,9	9,3	9,2	38,2	45,0	22,6	6,1	1,1	7,1	17,8	30,4
2	9,9	9,4	9,2	37,5	44,8	22,3	5,1	2,1	7,1	19,5	32,4
3	9,9	9,4	9,3	37,7	45,2	22,8	5,1	1,1	6,1	19,9	33,5
4	9,9	9,3	9,2	35,9	42,1	21,1	6,1	1,1	7,1	17,3	29,5
5	9,9	9,4	9,2	37,3	44,1	22,0	5,1	2,1	7,1	18,2	30,8
6	9,9	9,3	9,2	37,3	45,0	22,6	6,1	1,1	7,1	20,6	34,4
7	9,9	9,4	9,3	37,5	45,0	22,8	5,1	1,1	6,1	20,0	33,8
8	9,9	9,4	9,3	37,0	44,2	22,2	5,1	1,1	6,1	19,5	32,7
9	9,9	9,4	9,3	36,6	43,9	22,0	5,1	1,1	6,1	19,9	33,3
10	9,9	9,4	9,2	36,5	43,9	21,6	5,1	2,1	7,1	20,3	33,2
11	9,9	9,4	9,2	36,4	43,8	21,8	5,1	2,1	7,1	20,3	33,6
12	9,9	9,4	9,3	37,7	45,7	22,7	5,1	1,1	6,1	21,2	34,8
13	9,9	9,4	9,3	37,3	44,9	21,9	5,1	1,1	6,1	20,4	33,0
14	9,9	9,4	9,3	36,9	44,7	22,3	5,1	1,1	6,1	21,1	34,8
15	9,9	9,4	9,3	36,9	44,3	22,1	5,1	1,1	6,1	20,1	33,3

4 Conclusions

The engineering of artificial coral reefs was made of ceramic. The steps to make it were making designs, measuring and testing the physical properties, and making the models. The hexagonal design was used to make making the formation easier and has aesthetic value. The value of the physical properties of ceramics can be used as a basis in this manufacture. Total shrinkage value can be used to estimate material requirements also the water absorption and apparent porosity as the parameters of CaCO₃ circulation if this model is installed as an artificial coral reef on the seabed.

References

1. Presiden Republik Indonesia. UU No.32 Tahun 2014, Bab V, Pasal 1 dan Pasal 2, (2014)
2. U.S. Census Bureau, International Data Base (demographic data) and USA Trade Online (trade data), 1 July, (2021), (<https://www.census.gov/popclock/world>)
3. Hadi, T.A. et.al. The Status of Indonesian Coral Reefs. Research Center for Oceanography, p.1, Indonesian Institute of Sciences (2020)
4. Reefwest. Artificial Reefs in Australia: A Guide to Developing Aquatic Habitat Enhancement Structures, P.2, Suite 3, 45 Northside Drive, Hillarys, Western Australia, (2014)
5. S.C.A. Ferse. Artificial reef structures and coral transplantation: fish community response and effect on coral recruitment in North Sulawesi/Indonesia. Dissertation to obtain the doctoral degree of natural sciences, p.17, Center for Tropical Marine Ecology, University of Bremen (2008)
6. B. Mudjiyanto, E. Nur. Semiotics In Research Method of Communication. Journal of Communication Research Informatics and Mass Media - PEKOMMAS, **Vol. 16**, No. 1 (2013)
7. Kalam A, Mieno T, Casareto BE. Development of Artificial Reefs Using Environmentally Safe Ceramic Material. *J Ecosys Ecograph* **8**: 253. (2018)
8. Effendi, M.D, et al. Identifikasi Mineral Lokal Batuan Gayo dan Pemanfaatannya sebagai Massa Raga Keramik Stoneware, *JST (Journal of Sains & Technology)*, **Vol.1** No.7 (2018)
9. H. Magawe. Karakterisasi Hasil Sinter Reaction Bonded Alumina (RBAO) Dengan Penambahan Tepung Jagung. Thesis, Departement of Mechanical Engineering, University of Kristen Petra, Surabaya, Indonesia (2007)
10. Edwards, A.J. & Gomez, E.D. Konsep dan panduan restorasi terumbu: membuat pilihan bijak di antara ketidakpastian. Translate from Reef Restoration Concepts and Guidelines: making sensible management choices in the face of uncertainty. By: Yusri, S., Estradivari, N. S. Wijoyo, & Idris, iv + 38 pages Yayasan TERANGI, Jakarta (2008)