

Non-invasive leakage detection & localisation technique in noisy industrial environment

Theofilos Efstathiadis^{1*}, Anestis Kalfas^{1†}, Georgios P. Kousiopoulos², Georgios N. Papastavrou², and Spiros Nikolaidis^{2‡}

¹AUTH, Department of Mechanical Engineering, Laboratory of Fluid Mechanics and Turbomachinery, 54624 Thessaloniki, Greece

²AUTH, Faculty of Sciences, School of Physics, Department of Electronics and Computers, 54124 Thessaloniki, Greece

Abstract. An innovative non-invasive method for pipe leak detection and localization in noisy environment is presented in this paper. Nowadays, it is well known that complex pipeline networks are used for operational purposes and fluid transportation in every high-end-technology heavy industry such as refineries, combined heat and power cycles, cement and steel industries, etc. In all these cases, safety is the key parameter in order to ensure the efficient plant operation and to avoid any possible accident with devastating consequences that may lead to a turn down of the production process. For this reason, it is mandatory to develop reliable enough methods for detection of fluid leakages which represent the most common threaten in pipeline networks. Towards to this direction an integrated experimental setup was built in order to validate the results of the algorithm which was also developed for the purposes of the present study and aims to detect and locate the artificial leakages through the attenuation of the acoustic signal propagating in a pipeline. This experimental setup consists of pipelines that installed into an anechoic chamber and uses pure water as working medium. Apart from the high-efficient accuracy of the developed algorithm in the leakage detection and localization, the proposed method was designed with extra focus on the reduced CAPEX and OPEX costs. Finally, according to the results the proposed system gives sufficiently low false alarm regarding the leakage detection, while the mean percentage error of the leakage localization is around 6% which is considered as an acceptable value.

Nomenclature

Abbreviations

CAPEX	Capital Expenditures
OPEX	Operating Expenses
GCC	Generalized Cross-Correlation
BCC	Basic Cross-Correlation
PHAT	Phase Transform
BSS	Blind Source Separation
WT	Wavelet Transform
LPG	Liquid Petroleum Gas
RMS	Route Mean Square
AE	Acoustic Emission

Symbols

c	Sound velocity in the pipeline
x	Distance between leakage and sensor 1
L	Distance between two sensors
a	Attenuation coefficient
V	RMS value of voltage signal

E Wave energy

Subscripts

0	Leakage point
1	Sensor 1 point
2	Sensor 2 point

1 Introduction

Pipeline networks are commonly used for many reasons in almost every industries and commercial applications. They can be used for transportation of fluid products such as heavy oils and natural gas between different cities and countries or inside a specific factory for operational purposes. Moreover, pipeline networks have been built in urban areas for water and sewer grids for the improvement of the daily life of the inhabitants. In all cases mentioned before and in even more applications of fluid transportation, the usage of pipeline networks is generally considered as a safe process. However, in many cases the occurrence of leakages in a piping network will impose serious problems that may add extra risk in the normal and

* Theofilos Efstathiadis: theofil@auth.gr

† Anestis Kalfas: akalfas@auth.gr

‡ Spiros Nikolaidis: snikolaid@physics.auth.gr

secure operation of the system that hosts these pipelines. Plenty of reasons may lead to leakages appearance in a pipeline with non-desirable results such as product loss, environmental pollution or even hazardous accidents. To avoid all these obstacles/problems plenty of leak localization techniques that based on different working principles have been referred in the literature. These techniques may vary on the type and number of the required sensors, the power consumption, the needed execution time, the implementation cost, etc. [1,2]. Most of proposed techniques are focused on the accuracy enhancement of the leak localization but none of them takes into consideration the effects of a noisy environment.

Out of plethora of proposed technical solutions the most interesting category of leak detection and localization is the one that based on the acoustic emissions which created when a leakage happens in a pipeline [3,4,5]. The leak existence leads to the creation of vibro-acoustic waves which propagate in both directions across the pipe while carrying the required information for the identification of the leakage point.

The work done by Meng et al. in [6], uses the produced acoustic waves to detect the leak position by means of the cross-correlation technique. Two sensors were mounted at both ends of a straight pipeline and after the implementation of the cross-correlation function between the signal received by the sensors and the calculation of the time difference of signal arrival they were able to obtain the leakage position. Also, they have taken into consideration the velocity of the fluid inside the pipe except for the propagation velocity of the acoustic waves in order to enhance the accuracy of the method.

In [7], Choi et al. and Almeida et al. have employed the generalized cross-correlation (GCC) method to calculate the time difference of the acoustic wave arrival. A modified ML (maximum-likelihood) prefilter was used by Choi in the GCC function, while Almeida [8] made a comparison between the efficiencies of the BCC and PHAT prefilter. Results shown that the case of BCC pre-filter presented better estimation of the time difference, since it was not affected too much by the systems resonances which may increase the error in the time difference calculation. The same outcome is also presented in [9] regarding the accuracy of the BCC pre-filter when is used in GCC technique, where a straightforward comparison between the BCC and Roth pre-filter was done.

Moreover, Liu et al. in [10] have developed an in-house method which consists of four techniques and has the ability to identify and localize a leak depending on the situation and the way that the sensors are installed on the pipe. Two out of four techniques were based on the combination of the cross-correlation function with the Blind Source Separation (BSS) and the Wavelet Transform (WT), while the other two approaches rely on the amplitude attenuation of the acoustic signal.

Another approach has been proposed by Jiao et al. in [11] in order to identify the location of a leakage. In that case, where the proposed method is based on the separation of the different modes that contained in an

Acoustic Emission, only one sensor may be used according to the researchers.

In all cases listed before for leakage detection and localization in pipelines, the key parameter is the enhancement of the accuracy in the estimation of the leakage position. However, another very crucial parameter in leak detection and localization procedure is the time needed by a method until it provides results to the user, especially for the cases where flammable and dangerous fluids are contained in the pipeline network like the ones treated in a refinery. In such cases the detection and localization of a possible leakage must be quickly recognized before dangerous accidents and environmental pollution take place because of the oil product loss. Also, another important issue which is not yet investigated in the literature is the ability of the proposed method to operate efficiently under noisy environment without any false alarms.

The development of a fast response leakage detection and localization method is presented in this paper while taking into consideration the effects of a high-noise environment. The method is based on the attenuation of the leakage acoustic waves' energy as they propagate in the pipeline. The proposed method has been developed for the pipeline network of the Hellenic Petroleum refinery located in Thessaloniki, Greece and it was further validated by the experimental setup which was built in the Laboratory of Fluid Mechanics and Turbomachinery of Aristotle University of Thessaloniki. Proper filtering was applied during measurements in order to deal with external noise and extra focus was given in the minimization of the position error of the leak and the measurement duration which affects the response time.

2 Theoretical background

It's well known that vibro-acoustic waves are generated and traveling in both directions when a leakage takes place in a pipeline. As the acoustic waves propagate across the pipeline, the energy decreases exponentially while moves away from the leakage point [12]. This leads to a corresponding depletion of the amplitude of such waves. This phenomenon may be used for the leakage localization inside a pipeline.

The method used to identify the leakage location is based on the attenuation of the acoustic signal; it will be discussed hereafter, with the help of Figure 1.

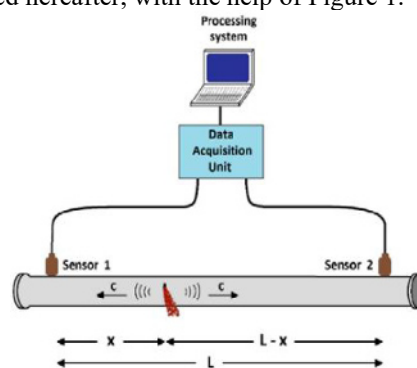

Fig. 1. Pipeline setup for leakage localization based on acoustic signal attenuation

As it can be noticed in figure 1, two sensors are mounted on the outer pipe's surface at a known distance L among them. If a leakage will occur in a certain location, acoustic waves will propagate from this point on to both edges, where the sensors are mounted. The initial energy of the acoustic wave (at leakage point) is equal to E_0 , while at sensor 1 and sensor 2 the energy equals to E_1 and E_2 respectively. It is needless to mention that E_1 and E_2 are smaller than E_0 due to the attenuation suffered by the wave travelling in the pipe. Moreover, if one considers the root mean square (RMS) of the voltage signal that measured by the sensor 1 and 2 as V_1 and V_2 respectively, and V_0 is the RMS value corresponding to the energy E_0 . The V_1 and V_2 are smaller than V_0 according to the following two equations which depict the attenuation of the acoustic signals.

$$V_1 = V_0 \cdot e^{-ax} \quad (1)$$

$$V_2 = V_0 \cdot e^{-a(L-x)} \quad (2)$$

where a is the attenuation coefficient ($a > 0$) and x is the distance of the leakage position measured from sensor 1. By dividing the previous two equations (1) and (2) we get:

$$\frac{V_1}{V_2} = e^{aL-2ax} \quad (3)$$

Finally, if we take the natural logarithm of both parts of equation (3) and solving for distance x , the mathematical equation for the leak position can be obtained by:

$$x = \frac{L}{2} - \frac{1}{2a} \ln \left(\frac{V_1}{V_2} \right) \quad (4)$$

From equation (4), which is also presented in [12], the leakage location can be determined by calculating the RMS values V_1 and V_2 if the attenuation coefficient is known as well. The calculation of the attenuation coefficient will be further analyzed in next chapter.

3 Experimental setup

As already mentioned in the Introduction, a test rig was built to experimentally validate the proposed method for leakage detection and localization. In particular, a dry cargo container was properly modified into an anechoic chamber by using noise insulating briquets in order to facilitate the experimental pipelines. The main reason of using an anechoic chamber is to allow only the industrial noise recorded in the premises of HELPE refineries in Thessaloniki into our test rig and simultaneously avoid any noise from the environment that may lead to a distortion of the measured acoustic signal. The industrial environmental sound was initially recorded close to three different pipeline networks at HELPE's premises and then induced inside the anechoic chamber by means of the SW-410 (80Watt) woofer which was connected with the BT7388 amplifier. These three pipelines are namely: i) E1404 which contains water for cooling purposes, ii) Dr-1452 which transfers atmospheric air for the production line, and iii) Sp-1407 which is flown by liquid petroleum gas (LPG). The experimental test rig consists of a closed-loop steel pipeline with an overall length of 25 meters.

Inside the container, a straight part of 10m pipeline (without any elbows) and a diameter of 77mm is installed. On this 10m section, all required measuring instrumentation and artificial leakages were hosted, as shown in Figure 2.



Fig. 2. Pipeline section inside the anechoic chamber

In particular, the experimental equipment that used is presented as follows:

- (i) Dry Cargo Container (40ft type) with 13.031m of length, 2.352m of width, 2.394m of height and total capacity of 67.74m³.
- (ii) Steel pipeline with 25m of total length.
- (iii) Five sets of four valves with 0.5, 1, 2 and 4mm of diameter located at different points on the pipe. These valves were used to emulate the leakages (Figure 3).
- (iv) An auxiliary piping system that works as sewer system and takes the wasted water out of the container (Figure 3)
- (v) Two manometers are also placed on the steel section inside the container (Figure 4).
- (vi) Two PCB-352C33 vibro-acoustic accelerometers mounted on the outer pipe's surface [13]
- (vii) A data acquisition unit which consists of the NI-9232 data acquisition card and the NI cDAQ-9174 chassis (Figure 5a, 5b) [14].
- (viii) A computer equipped with LabVIEW software.



Fig. 3. Artificial leakages by means of valves and plastic tube that used to avoid any flooding inside the container



Fig. 4. a) Pressure Transmitter
 b) Universal Display



Fig. 5. a) Vibro-acoustic accelerometer
 b) Data acquisition unit

Next to the container an engine room was installed in order to host all appropriate hydro and electro-mechanical equipment necessary for the smooth operation of the experimental setup (figure 6).

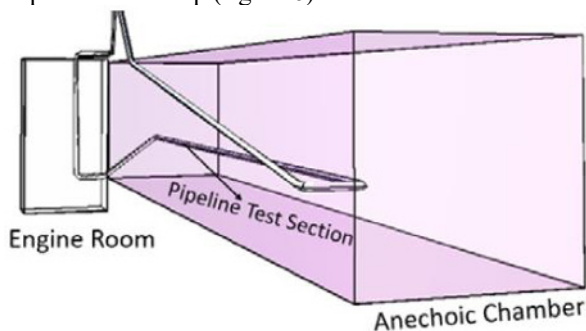

Fig. 6. Engine room next to anechoic chamber

The equipment needed for the experiment completion is presented below:

- (i) A control panel that contains all electrical fuses and the 4kW Inverter for the recirculation pump control.
- (ii) The recirculation pump and the feeding pump which determines the internal pressure of the working fluid (water) into the pipe.
- (iii) A magmeter for the mass flow and flow velocity identification (figure 7a)
- (iv) Two expansion tanks with a maximum capacity of 700lt (200lt + 500lt) were installed to avoid any steep pressure drop while water wasted through the artificial leakages (figure 7b).



Fig. 7. a) Endress+Hauser Magmeter
 b) Expansion tank

Prior to each measurement of the acoustic signal that is produced by the artificial leakages, the desired pressure and temperature are mandatory to be set from a researcher inside the engine room. The recirculation pump is also controlled by the same person from the control panel in order to simulate the exact same conditions of the refinery while in operation. Additionally, two more researchers inside the container conduct the experimental measurements. The first one turns on the valve of the corresponding leakage that is under examination in various positions on the pipe while the second researcher controls the computer in order to record and save the acoustic signal. Meanwhile, the developed algorithm is run in the background in order to detect the occurrence and the position of the leakage by means of the AE method.

As mentioned in the theoretical background chapter, for the determination of the leakage position it is mandatory to know the attenuation coefficient “a” of the system [15]. For this reason, a set of leakages are emulated at a certain positions on the pipe for the calculation of the RMS values of the acoustic signals that obtained by the sensors. These results are then plotted in a diagram versus the distance of the sensor from the leakage point and an exponential fitting is performed. The same procedure takes place for both sensors. For example, the exponential fitting for the sensor Nr2 is presented in figure 8. By comparing the results derived from the two fittings with equations (1) and (2), two different, but very close to each other values are obtained for the attenuation coefficient. The average of these two values gives the attenuation coefficient of the system.

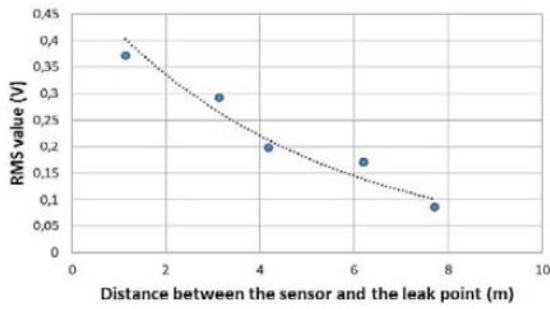

Fig. 8. Exponential fitting of sensor Nr2

The attenuation coefficient determination follows another set of measurements of artificial leakages at different points compared to the ones used for the attenuation coefficient extraction, in order to validate the efficiency of the developed algorithm. Key aspects of the proposed method are the ability to operate under high-noise environment and present adequate accuracy while taking samples with short duration. For the latter aspect, leak measurements with different durations were conducted and estimation accuracy of the leak position was tested. For long sampling duration, a leakage detection system does not response fast enough, so it is unable to provide quick alarm to the user. Regarding the noisy environment, as mentioned before, recorded noise was added to the initial measurements, by using LabVIEW software and proper filtering was applied as described in [16]. Afterward, the proposed method was re-employed, and the accuracy of leakage position was tested as well. Results for both acquisition duration and the ability of the method to localize leaks in high-noise conditions are presented in the following section.

4 Results analysis

As described in earlier chapters, experimental measurements were conducted inside the anechoic chamber in order to test the ability of the proposed method to detect and localize leakages in high-noise situations with short data acquisition time. Plenty of tests were made and the results for leakage localization for various sampling duration, with and without noise, are presented below (Table 1 – Table 6). The corresponding error rate is expressed as the percentage error in position to the distance between the two sensors, which is 8.5 m. Once more it should be noticed that the induced noise was adjusted in such a way to emulate the noise of the HELPE’s environment. The extracted attenuation coefficient was equal to 0.196 m⁻¹ for the case without noise and 0.215 m⁻¹ for the case with noise. One very interesting conclusion is that the existence of the noise does not affect the attenuation coefficient, because the relative error between these two values is below 10%.

Table 1. Measurements duration 5sec (without noise)

	Without Noise		
	Real Value of x(m)	Estimated Value of x(m)	Error (%)
Leak point 1	0.78	1.60	9.7
Leak point 2	2.29	2.28	0.1
Leak point 3	4.31	4.07	2.8
Leak point 4	5.36	5.50	1.7
Leak point 5	7.36	8.28	10.8

Table 2. Measurements duration 0.1sec (without noise)

	Without Noise		
	Real Value of x(m)	Estimated Value of x(m)	Error (%)
Leak point 1	0.78	1.20	5.0
Leak point 2	2.29	2.34	0.6
Leak point 3	4.31	3.95	4.3
Leak point 4	5.36	5.33	0.3
Leak point 5	7.36	7.97	7.2

Table 3. Measurements duration 0.005sec (with noise)

	Without Noise		
	Real Value of x(m)	Estimated Value of x(m)	Error (%)
Leak point 1	0.78	1.18	4.7
Leak point 2	2.29	2.41	1.4
Leak point 3	4.31	3.75	6.6
Leak point 4	5.36	5.43	0.9
Leak point 5	7.36	7.97	7.2

Table 4. Measurements duration 5sec (with noise)

	With noise		
	Real Value of x(m)	Estimated Value of x(m)	Error (%)
Leak point 1	0.78	1.40	7.3
Leak point 2	2.29	2.34	0.6
Leak point 3	4.31	3.93	4.5
Leak point 4	5.36	5.83	5.6
Leak point 5	7.36	7.80	5.1

Table 5. Measurements duration 0.1sec (with noise)

	With noise		
	Real Value of x(m)	Estimated Value of x(m)	Error (%)
Leak point 1	0.78	1.43	7.7
Leak point 2	2.29	2.55	3.1
Leak point 3	4.31	3.86	5.3
Leak point 4	5.36	5.36	0.0
Leak point 5	7.36	8.52	13.7

Table 6. Measurements duration 0.005 (with noise)

	With noise		
	Real Value of x(m)	Estimated Value of x(m)	Error (%)
Leak point 1	0.78	1.49	8.4
Leak point 2	2.29	2.38	1.0
Leak point 3	4.31	3.72	6.9
Leak point 4	5.36	4.16	14.1
Leak point 5	7.36	8.59	14.4

According to results gained from Tables 1 - 6, the minimum acceptable acquisition time for the proposed method is 0.1 seconds. From tables 1,2,4 and 5, it can be seen that for acquisition duration of 0.1 sec and above, the localization accuracy remains in acceptable limits for both cases with and without noise. However, below this duration limit, the position error is steeply increased for some cases (see table 6, leak point 4 and 5). At this point, it should be mentioned that in all cases (tables 1 – 6) only the leakage points 2,3 and 4 were taken into consideration, as the other leakages at point 1 and 5 are placed very close to the pipe elbows where reflected waves were created. This fact makes the acoustic signal produced from either of these two leakages to reach the pipe wall at the elbows with small decrease in amplitude, since the propagation distance is small, and therefore non-neglectible reflected waves are generated. This effect causes errors as also described in [12]. More particular, a complex signal which consists of the original leak signal and the reflected one was received by the sensors placed near the pipe elbow. For this reason, the final decision of where to place the sensors is of high importance and should be done with utmost care.

Finally, if one makes the comparison of results between the cases without noise (tables 1-3) and the corresponding ones with noise (tables 3-6), it can be understood that the leakage localization method is a reliable technique even if operates under high-noise conditions. The maximum errors for each of the aforementioned cases are provided in the table 7. Once more, it should be mentioned that only leakages at point 2, 3 and 4 were taken into consideration and did not suffer from reflected waves.

Table 7. Maximum error comparison

	Acquisition Duration	Maximum error rate (%)
Without Noise	5 sec	2.8
	10 msec	4.3
	5 msec	6.6
With Noise	5 sec	5.6
	10 msec	5.3
	5 msec	14.1

5 Conclusions

In the present work, a laboratory test facility was developed in order to examine the effects of high-noise environment on a leak detection and localization method. This method is based on the attenuation that a leakage acoustic signal suffers while propagating in a pipeline. The key parameters that examined are the ability of the method to operate with short acquisition time and the possibility to be employed the proposed method under high-noise conditions.

The selected point of the sensors mounting must be done very carefully in order to avoid any reflected acoustic waves and further research should be conducted for such cases. Finally, according to results obtained from measurements, the proposed technique can operate efficiently for data acquisition time, which is greater than 0.1 seconds and when combined with proper filtering, can provide reliable results even in noisy industrial environments.

6 Acknowledgments

This research has been co-financed by the European Regional Development Fund of the European Union and Greek national funds through the Operational Program Competitiveness, Entrepreneurship and Innovation, under the call RESEARCH – CREATE – INNOVATE (project code: T1EDK-00791).

References

1. L. Boaz, S. Kaijage. R. Sinde, *An overview of pipeline leak detection and location systems*, Proceedings of the Pan African International Conference on Science, Computing and Telecommunications, Arusha, Tanzania, 14-18 (July 2014).
2. A.F. Colombo, P. Lee, B.W. Karney, *A selective literature review of transient-based leak detection methods*, J. Hydro-environ. Res., 2, pp. 212-227 (2009).
3. S. Li, Y. Wen, P. Li, J. Yang, L. Yang, *Leak Detection and Location of Gas Pipelines Using Acoustic Emission Sensors*, Proceedings of the 2012 IEEE International Ultrasonics Symposium, Dresden, Germany (7-10 October 2012).

4. B. Pan, C. Xu, G. Cao, G. Chen, H. Shi, *A Method of Leakage Source Localization for Pipeline Based on Acoustic Emission Signal*, Proceedings of the International Conference on Pipelines and Trenchless Technology, Xi'an, China (16-18 October 2013).
5. F. Almeida, M. Brennan, P. Joseph, S. Whitfield, S. Dray, A. Paschoalini, *On the Acoustic Filtering of the Pipe and Sensor in a Buried Plastic Water Pipe and its Effect on Leak Detection: An Experimental Investigation*, *Sensors*, **14**, p. 5595-5610 (2014).
6. L. Meng, L. Yuxing, W. Wuchang, F. Juntao, *Experimental study on leak detection and location for gas pipeline based on acoustic method*, *J. Loss Prev. Process Ind.*, **25**, p. 90-102 (2012).
7. J. Choi, J. Shin, C. Song, S. Han, D.I. Park, *Leak Detection and Location of Water Pipes Using Vibration Sensors and Modified ML Prefilter*, *Sensors*, **17**, 2104 (2017).
8. F. C. L. Almeida, M. J. Brennan, P. E. Joseph, Y. Gao, A. T. Paschoalini, *The effects of resonances on time delay estimation for water leak detection in plastic pipes*, *J. Sound Vibrat.*, **420**, pp. 315-329 (2018).
9. G. P. Kousiopoulos, G. N. Papastavrou, D. Kampelopoulos, N. Karagiorgos, S. Nikolaidis, *Comparison of Time Delay Estimation Methods Used for Fast Pipeline Leak Localization in High-Noise Environment*, *Technologies*, **8**, 27 (2020).
10. L. Cuiwei, L. Yuxing, F. Liping, X. Minghai, *New leak-localization approaches for gas pipelines using acoustic waves*, *Meas.*, **134**, p. 54-65 (2019).
11. J. Jiao, C. He, B. Wu, R. Fei, *A new technique for modal acoustic emission pipeline leak location with one sensor*, *Insight*, **46**, No 7 (July 2004).
12. L. Cui-wei, L. Yu-xing, F. Jun-tao, L. Guangxiao, *Experimental study on acoustic propagation characteristics-based leak location method for natural gas pipelines*, *Process Saf. Environ. Prot.*, **96**, p. 43-60 (2015).
13. PCB Piezotronics, Model 352C33, *High sensitivity, ceramic shear ICP accelerometer*, Installation and Operating Manual.
14. *National Instruments*, Datasheet NI 9232, 3 AI, ± 30 V, 24 bit, 102.4 kS/s/ch Simultaneous.
15. G. P. Kousiopoulos, G. Papastavrou, N. Karagiorgos, S. Nikolaidis, T. Efstathiadis, A. I. Kalfas, *Pipeline Leak Localization Techniques*, Panhellenic Conference on Electronics & Telecommunications (PACET), 2019.
16. D. Kampelopoulos, G. N. Papastavrou, G. P. Kousiopoulos, N. Karagiorgos, D. Porlidas, S. Nikolaidis, *Defining Thresholds for Leak Detection Parameters Through Statistical Analysis of the noise in Water/Gas Pipelines*, Proceedings of the IEEE International Instrumentation and Measurement Technology Conference, Dubrovnik, Croatia in press (25-28 May 2020)