

How residential CHPs could be integrated in renewable energy communities' incentive schemes

Matteo Sforzini¹, Gianluigi Nicita¹, Lorenzo Pastore¹, Gianluigi Lo Basso¹, and Livio de Santoli¹

¹Department of Astronautics, Electrical and Energy Engineering (DIAEE), Sapienza University of Rome, Via Eudossiana 18, Rome 00184, Italy

Abstract. The present work aims to investigate the integration into renewable energy communities (REC) schemes of micro and mini-Combined Heat and Power (CHP) plants. In detail, it has been evaluated the minimum self-consumption (SC) share needed to even out the revenues coming from the energy efficiency certificates (EECs). In order to establish a SC based tariff for CHP plants a correlation between SC share and the tariff value has been assessed for different commercial plants. A 70% of SC share has been set as a minimum target, which is related to incentive rates of 53 and 39.5 €/MWh, for mini and micro-CHPs, respectively. These values are about 65% lower than the current tariffs set by ARERA (Italian Regulatory Authority for Energy, Networks and Environment) to reward the renewable energy SC. A real building and two CHP plants have been considered as reference case studies. A dynamic simulation has been carried out in order to analyse the proposed incentive scheme in a real application. Starting from a 3-D BIM model, the energy flows have been calculated over one year period. Finally, it has been demonstrated how a SC based tariff can significantly reduce the share of injected electricity into the grid, also promoting the thermal carrier sharing. In so doing, the renewable energy sources intermittency can be easily mitigated and balanced, avoiding additional burdens on public expenditure.

1 Introduction

With the introduction of the European Directive 2018/2001 (RED II) it has been established a common system to promote energy from renewable sources. Renewable Energy Sources (RES) are crucial to mitigate climate change effects [1]. However, RES are variable and non-programmable sources, and their increase will require different solutions to improve system flexibility and to balance the power grid [2]. Even in small-scale energy systems, the system flexibility has to be increased in order to integrate high shares of variable RES [3][4]. Moreover, to balance the local power grid, CHP (Combined Heat and Power) plants are an interesting option [5][6][7]. Nowadays, CHP plants are a widely used commercial technology [8]. Different alternative fuels [9][10], like biomass [11] and hydrogen [12], are decreasing the environmental impact of these devices [13][14].

Promising application of this technology is the integration in a hybrid energy system, which may combine different technologies such as RES [15][16], heat pumps (HP) [17], CHP plants [18], Gas Absorption Heat Pumps (GAHP) fuelled with hydrogen enriched natural gas (H₂NG) blends [19], boilers and BIPV (Building Integrated Photovoltaics) [20]. It has been demonstrated that this type of configuration, which couple traditional thermodynamic cycles with renewable-based devices, along with effective management and control strategy [21][22], offers good opportunities to get higher environmental, energy and economic benefits in the short-medium term. Several studies regarding the Smart Energy Systems (SES), in the last decade, have been carried out in order to identify the best technical options and strategies to globally reduce the primary fossil energy consumption (PFEC) and to integrate the large amount of variable RES (VRES) available [23].

The small-scale application of this approach is particularly interesting for new collective self-consumption (CSC) and renewable energy communities (REC) schemes. Furthermore, a CHP option may be helpful to extend the possibility to create a REC or CSC where renewable sources are discontinuous or insufficient, for instance at high latitudes [24] or in rural areas [25][26].

In Italy, in order to maximise the self-consumption and to reduce the general injection coming from distributed generators, a regulatory framework is being developed that allows to create REC and CSC schemes, characterised by strong incentives on self-consumed energy. However, the current Italian legislation does not include CHPs among eligible plants.

In this study, it has been explored the extension feasibility of these innovative schemes to micro and mini-CHP plants. In detail, the main purpose is to analyse, from a technical and economical point of view, how this technology may be integrated to REC in order to reduce as much as possible the amount of energy requested and injected in local grid. Thus, it has been evaluated the minimum self-consumption share needed so as to even out the revenues coming from the present Energy Efficiency Certificates (EECs). Furthermore, it has been carried out a sensitivity analysis on the self-consumption percentage, for collective communities and REC, with varying the incentive rate and maintaining the goal of even out the revenues coming from EECs. In order to validate theoretical results, a CHP machine has been used as a reference device to create a dynamic model applied on a real building, modelled by three-dimensional BIM software, which is characterised by five floors and 4,500 square meters of usable surface. The analysis has been extended to different CHP sizes to consider typical machines which may be chosen in residential contexts.

2 Case study description and methodology

The reference building assumed for this study consists of a building detached structure located within the Roman municipality, right beside the consular road Via Tuscolana and halfway between Rome and Frascati. It was built in 1952, and it was originally a generalate house of a religious order; it has been recently refurbished in order to reduce the residential space and to include an assisted living facility preserving the original foundations and a fraction of perimetral walls. It is characterised by 4,500 m² of net floor surface divided in five floors, included the ground and basement floor. Part of the building, highlighted in red in the Figure 1, is currently used as generalate house, while the other section, highlighted in yellow, is designed to the assisted living facility; the second section also encapsulates a chapel. This building has been chosen because of its similarity to a residential condominium, in terms of energy loads profiles.



Fig. 1. Aerial picture of the reference building

As a result of building energy analysis, the PTHR (Power To Heat Ratio), defined as the ratio between the electrical energy consumption and the thermal one for the building, has a value equal to 0.39.

As regards the Heating Ventilation Air Conditioning (HVAC) plant, the building is equipped with two boilers and an electric chiller, which provides to three Air Handling Units (AHUs), fan coils displaced in all rooms with hot and cold water. The AHUs deliver a higher air flow rate to the assisted living facility than to the residential space one, due to the more restrictive legislation in the building ventilation field.

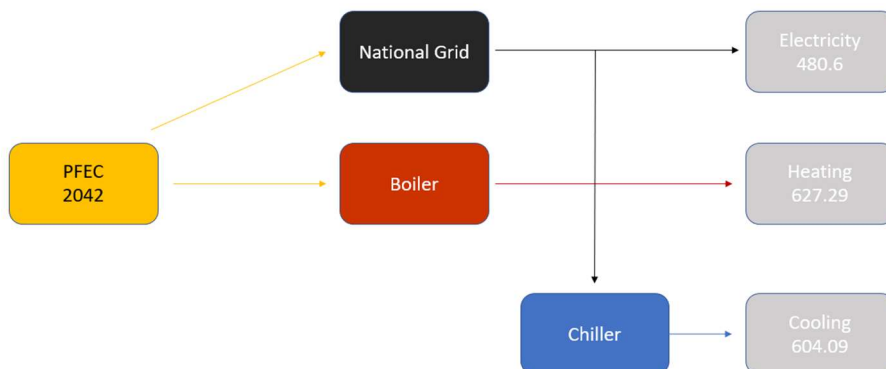

Fig. 2. Reference Scenario, energy consumptions in MWh/yr

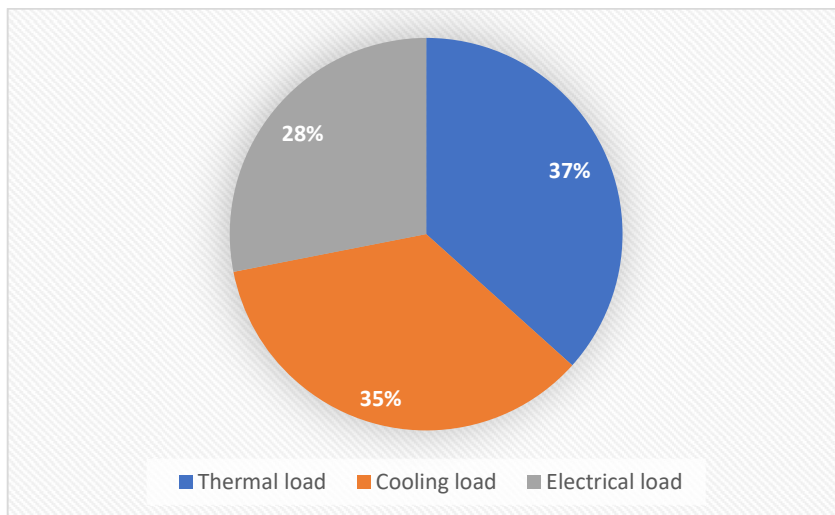

Fig. 3. Building energy breakdown

Building energy analysis has been carried out by a dynamic software, namely Termolog, which is certified by the Italian Thermotechnical Committee (CTI), in order to identify electrical, heating and cooling needs over one year-period, as well as the energy distribution (Figure 3). In detail, by knowing the structures orientation, building materials, spaces division and human occupancy, it has been possible to simulate reliable energy data. To quantify the cooling loads, Termolog uses a semi-dynamic methodology (Pizzetti-Carrier method), based on UNI-TS 11300 which accounts the accumulation factors. MATLAB-Simulink software has been then used in order to simulate dynamic scenarios influenced by active variables; its primary interface is a graphical block diagramming tool and a set of block libraries. Thus, the model itself consists of several subsystems: each of them represents a specific component, in which the governing equations and the correlations, are shown and linked together, using blocks and streams. European Tool of Joint Research Centre has been used to define the Typical Meteorological Year (TMY).

The integration into REC schemes of micro and mini - CHP plants, which are currently not included in the Italian legislation, has been analysed considering the minimum SC share needed to even out the revenues coming from the EECs. For that reason, in each scenario it has been evaluated both the incentives amount hailing from EECs and from the innovative schemes of REC and CSC. In the dynamic simulations it has been setup the 70% of SCR as a minimum target; indeed, close to that value it has been reached the so called “sweet-spot” between the incentive rates and the machine operating hours. To perform simulations, eight different CHP sizes have been compared each other; the assumed size span is ranging between 11 kW_{el} and 200 kW_{el}, in order to include a significant number of machines which can be applied in the residential context, and which can be included in the new incentive mechanism. It is noteworthy that the current technical regulations call for a maximum threshold limit of installed capacity equal to 200 kW_{el}. For each CHP it has been calculated PES (Primary Energy Saving) and RISP values, considering their characteristics, and the hypothetical revenues deriving from the application of a fixed tariff and of a variable one. The aim of this comparison is to identify the minimum SCR to event out the EECs, under the same operating conditions, and the amount of public contribute having fixed the SCR target at 70%.

2.1. Hybrid system layout description

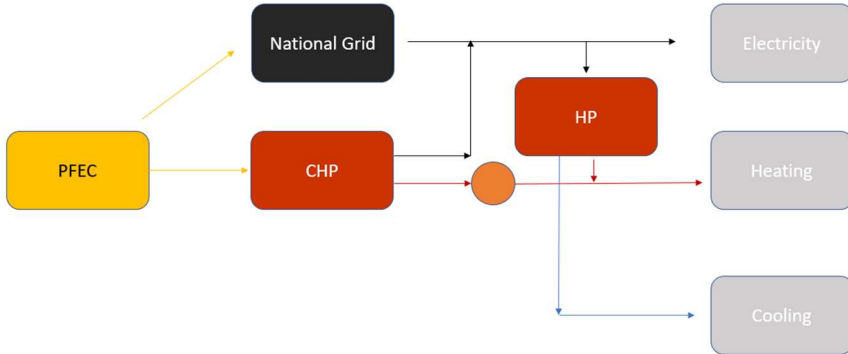

Fig. 4. Hybrid configuration systemic overview

The hybrid layout proposed consists of a CHP engine, a reversible heat pump and a storage vessel which has been sized considering 50 litres per kW_{th} (Figure 4). The presence of a vessel enhances the CHP operating hours and cost effectiveness by increasing its thermal energy production, and the self-production of electricity. From simulations, it emerges how the full load hours are greater than 3,500 hours in most of cases. The CHP coupling with a heat pump has been also considered so as to increase system reliability in case of CHP malfunctions or maintenance.

The hybrid systems energy balance equations read as follows:

$$E_{el, HP} + E_{el, Building} = E_{Grid} + E_{el, CHP} \quad (1)$$

$$E_{H, Building} = E_{H, CHP} + E_{H, HP} \quad (2)$$

where the energy balance equations (1-2) have been written in terms of useful energy, equating the energy production hailing from devices to the building energy needs.

Furthermore, an iterative calculation process has been included in dynamic simulations to calculate the PFEC values. To do so, the CHP electric capability has been assumed as the variable to be iterated. Consequently, the following differential condition and constrain equations have been added to optimize the objective function:

$$\frac{dE_{el,CHP}}{dE_{fuel,sys}} = 0 \quad (3)$$

$$E_{el,grid} \geq 0 \tag{4}$$

$$PFEC = \frac{E_{grid}}{\eta_{el,grid}} + E_{fuel,CHP} \tag{5}$$

Thereafter, the hybrid systems primary fossil energy consumption can be calculated by Equation (5) once the conversion efficiencies of the CHP device are known. As regards the primary fossil energy consumption associated to the national grid, a further clarification must be made. As a matter of fact, the electricity production hails from the national energy mix typology, which involves different fossil fuels and renewable energy sources as well. The national energy mix composition can be taken into account, in a first approximation, by the value of grid electrical efficiency. Therefore, the PFEC value reported in Equation (5) is the sum of primary fossil energy consumption of NG-based devices and the national grid one.

2.2. Simulink blocks description

2.2.1. CHP Block

CHP system has been modelled to simulate the electricity and hot water production as well as its fuel consumption. Its own control system has been modelled just to follow the water temperature detected within the vessel; that technical option allows the machine decoupling from building load fluctuations. The CHP Simulink block can also calculate the electricity and thermal outputs once the engine runs in partial load conditions. In order to evaluate the SCR values, it has been implemented a real-time calculating procedure which is able to compute the ratio between the produced energy and its consumption within the community.

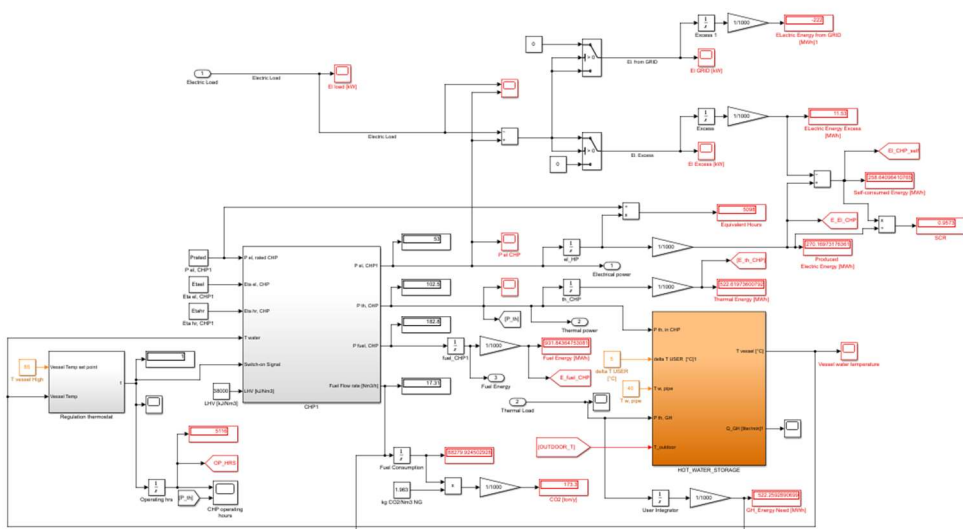

Fig. 5. CHP model with Vessel (filled with the orange colour)

Furthermore, to increase, as much as possible, the CHP heat recovery efficiency, every subsystem has been equipped with a further block simulating an additional condensing heat exchanger to fruitfully exploit the latent heat in the exhaust gas. Furthermore, the subsystem takes into account the CHP activity by continually monitoring the fuel supply. The formal equations used to build that specific subsystem have been found in literature [12], and they read as follows:

$$\phi_{exchanger} = \phi_{sensible} + \phi_{latent} \quad (6)$$

$$\phi_{sensible} = \sum_{j=0}^N (\dot{m}_{f,(j)} - \dot{m}_{H_2O,cond,(j+1)}) * c_{p,f,(j+1)} * \Delta T \quad (7)$$

$$\phi_{latent} = \eta_{condens} * \delta_{blend} * q_{blend} = \eta_{condens} * (HHV - LHV) * q_{blend} \quad (8)$$

Where:

$\phi_{exchange}$ is thermal power recovered by the shell/tube heat exchanger [kW_{th}]

$\phi_{sensible}$ is sensible thermal power recovered by the shell/tube heat exchanger [kW_{th}]

ϕ_{latent} is thermal power from condensation [kW_{th}]

\dot{m}_f is exhaust gas mass flow rate [kg/s]

$\dot{m}_{H_2O,cond}$ is condensed water mass flow rate [kg/s]

$c_{p,f}$ is exhaust gas specific heat at constant pressure [kJ/kgK]

ΔT is the difference between inlet and output exhaust temperatures

$\eta_{condens}$ is condensation efficiency

δ_{blend} is water mass content per fuel unit of volume

q_{blend} is blend flow rate [Nm³/s]

$HHV - LHV$ is the difference between H₂NG blend Higher Heating Value and Low Heating Value [MJ/Nm³]

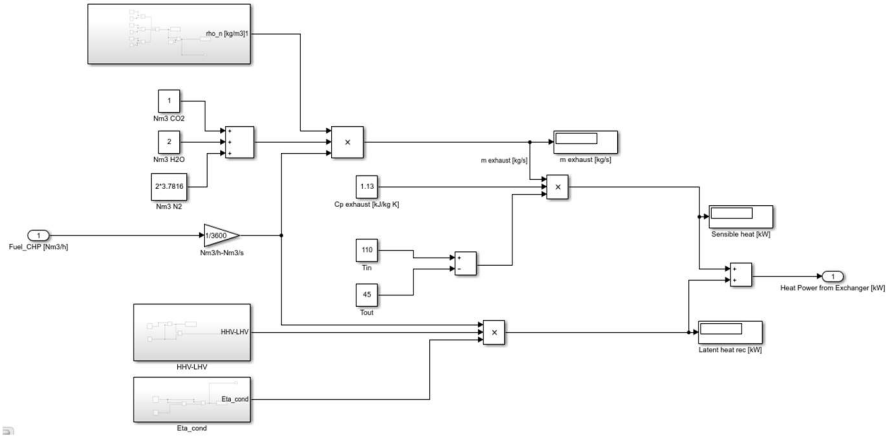

Fig. 6. Condensing heat exchanger Simulink block

Connected to the CHP block has been developed a second one, which calculates the PES values and the number of White Certificates (EECs) that the machine can assure the client. To do so, this block uses the outputs coming from the CHP model and formulas approved by GSE (Gestore Servizi Energetici) [27]. That block has been added in order to check the cogeneration sustainability and to calculate the revenues coming from the EECs. The economic value of White Certificates has been assumed according to the average quotation provided by Italian authority, i.e. Gestore Mercati Energetici (GME).

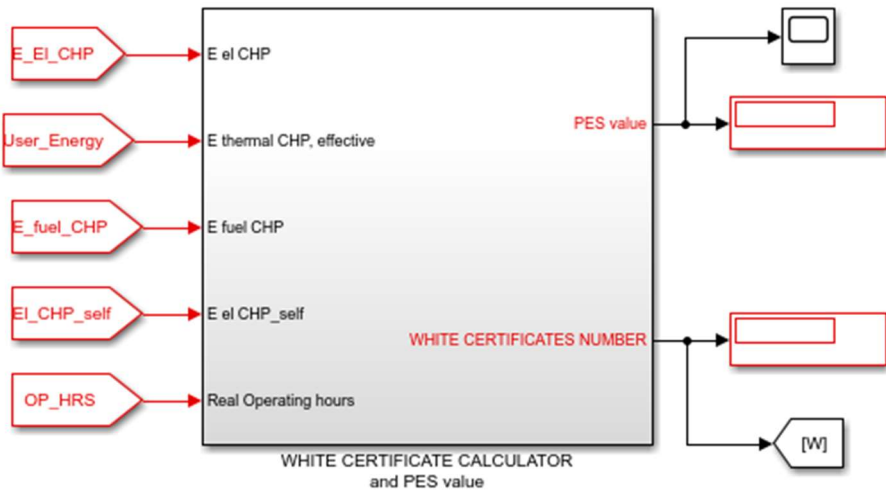

Fig. 7. White Certificates (EECs) and PES model

2.2.2. Vessel block

In this block it has been simulated the hot water storage, coming from the CHP; it also considers the energy loss due to the temperature difference between water and outdoor air. The model can be adapted to various scenarios by modifying vessel characteristics like storage temperature, vessel volume or insulation. Within that block, there is another one to simulate a mixing three-ways valve.

2.2.3. Heat Pump

This system has been built to use as inputs the external temperature data, the fixed supply water temperature, heating/cooling loads, and as outputs the EER/COP coefficients and the electric power needed. By means of the “lookup table” blocks, it has been possible to create interpolated curves based on real values of existing machines to describe EER/COP and power variations with changes in operating conditions. The Heat Pump block has been provided with a specific activation block, since this machine operates all over the year; to switch from heater to cooling mode, and vice versa, the system counts the hours. In this specific case, the counter, modelled by two “switch” blocks and one “clock” block, has been set to follow the Italian D climate zone.

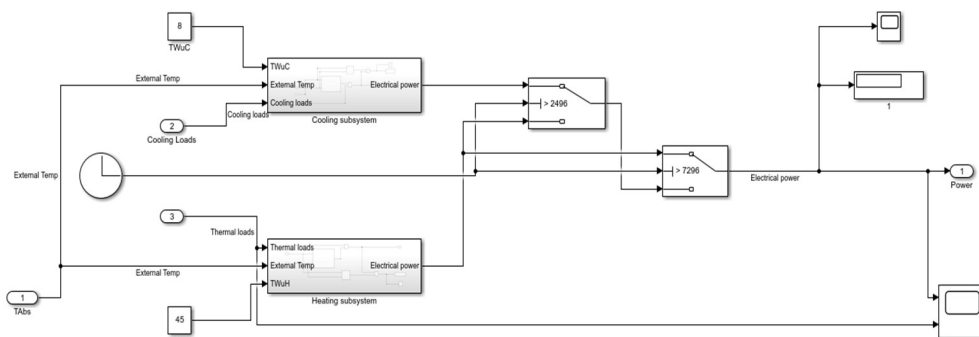

Fig. 8. Heat Pump block structure

3 Results and discussion

A preliminary analysis has been carried out in order to identify the SC-based tariff value, which allows to equalize the revenues from EECs mechanism, by changing the SCR. The outcomes are summarised in Figure 9. It is important to point out that the larger the SCR, the lower the tariff values are. The target level of SCR has been defined equal to 70%, then the SC-based tariff has been identified in a range between 53 and 39.5 €/MWh. Once the tariff has been set, if the CHP plant was managed in such a way to get a SCR higher than 70%, then the total revenues will be higher than those obtained by the EECs mechanism. On the contrary, a CHP plant that injects a lot of electricity into the grid and has a SCR less than 70%, it will receive lower revenues than those from previous incentive mechanism.

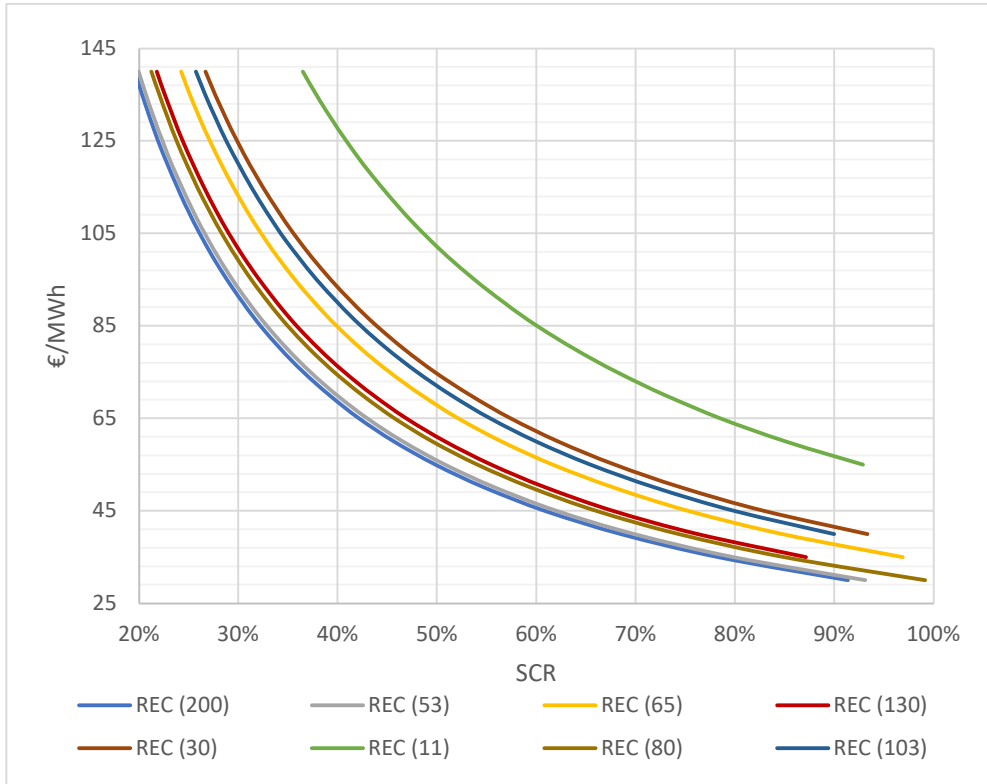

Fig. 9. Self-consumption ratio vs incentive rate (to even out the EECs rate)

The SC-based tariffs are, on average, 65% lower than the current tariffs set by ARERA to reward the energy SC from RES. Nevertheless, must be noted how the smallest CHP chosen is related to the highest incentive value, which is equal to 73 €/MWh. This is mainly due to the disparity of energy produced and requested by the reference building. The outcome connected to the 11 kW_{el}-CHP highlights a relevant risk, which nowadays is not often accounted for, i.e. under-sizing the CHP plant so as to accomplish the highest SCR. Despite this rule has been generally deemed appropriate, below a certain lower limit (i.e. here it has been identified in 53 kW_{el}), a different pattern has been observed; indeed, once the maximum SCR (100%) is reached, the incentive rate starts to increase, while the CHP size decreases. The just mentioned pattern is shown in Figure 10.

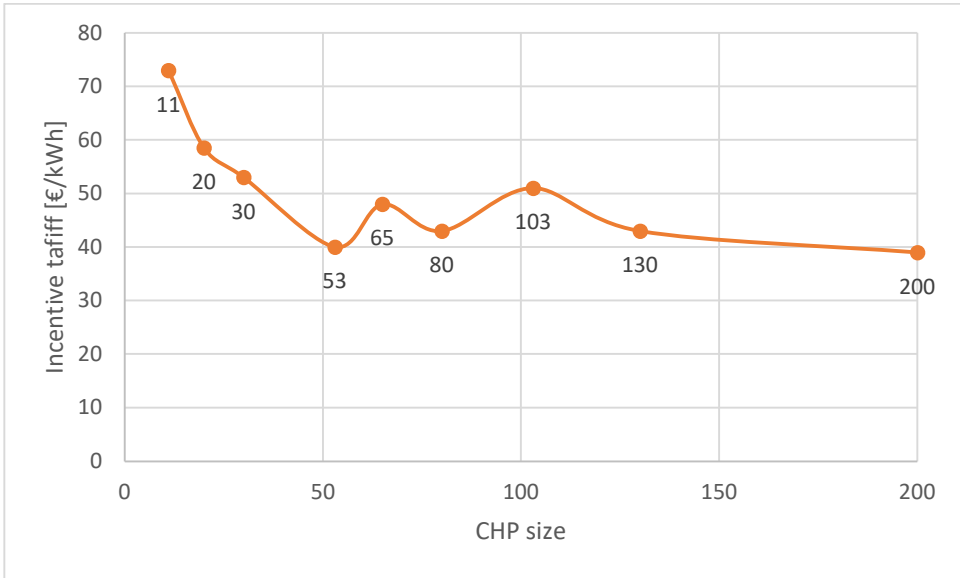

Fig. 10. Incentive tariff vs CHP size variation

Referring to the latter pattern, in this study, the identified relevant range is 53 kW_{el} and 103 kW_{el}. In the first case, i.e. for a CHP plant of 53 kW_{el}, the SCR reaches approximately the 100%. In the second case, i.e. for a CHP plant of 103 kW_{el}, the SCR is equal to 54.8% and their own full load hours are about 3,577. Furthermore, an additional increase of CHP size leads to a significant full load hours decrease, representing a plant cost-effectiveness lessening, and to very low SCRs as well.

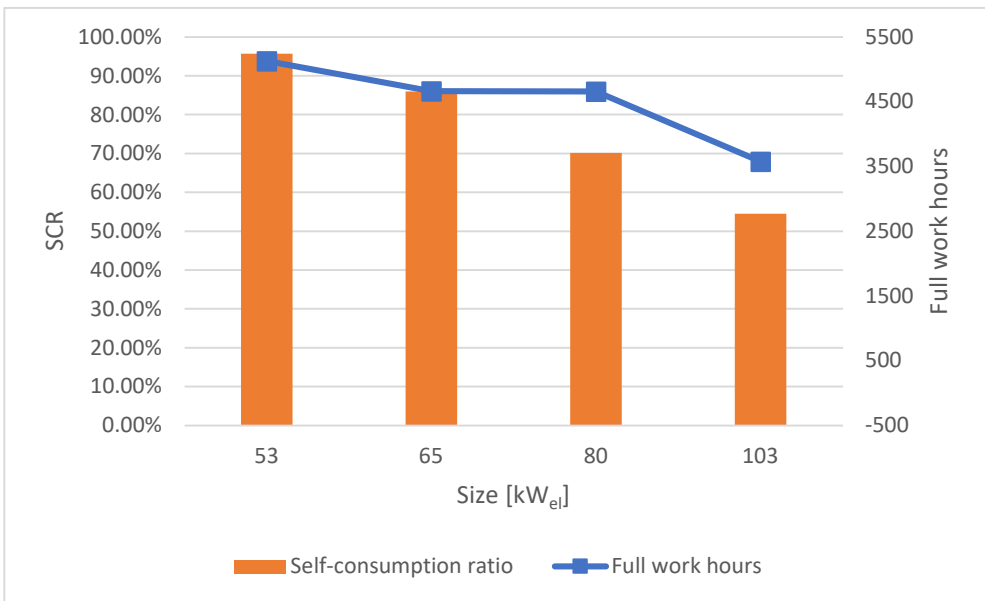

Fig. 11. Self-consumption ratio vs working hours

Therefore, a correct plant sizing process is crucial to achieve high SCRs and consequently, to do not cause trouble on the local electricity grid. From an economic point of view, the simulations shows that the economic parity of EECs and REC incentives has been substantially achieved with a CHP size of 80 kW_{el} size. By applying the SC-based tariff, the revenues from incentives are higher for small-size CHP plants. On the other hand, under the EECs scheme, oversizing the CHP plants allows to get more revenues from the incentive mechanism. The integration of CHP plants between the authorised technologies in the REC scheme, would promote more efficient projects design. This can lead to a better sizing process, to maximize the energy SC, and consequently, to reduce power grid fluctuations.

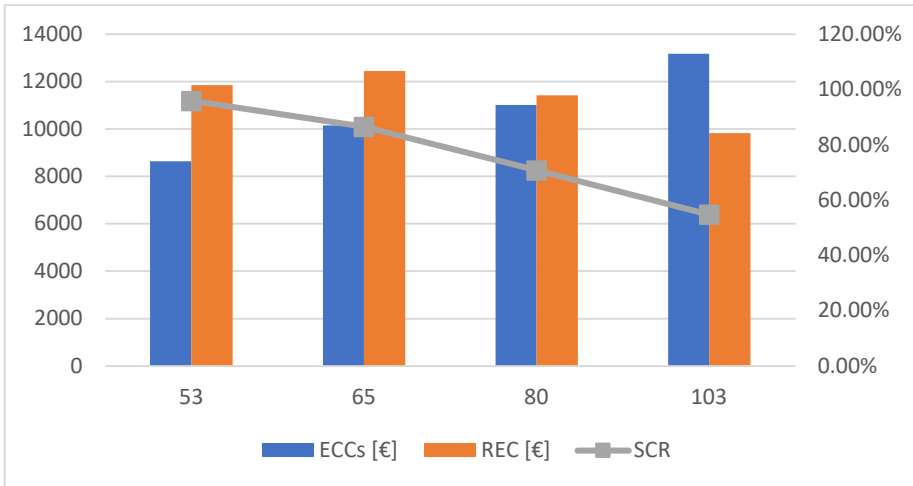

Fig. 12. Comparison between ECCs and REC revenues in year simulation

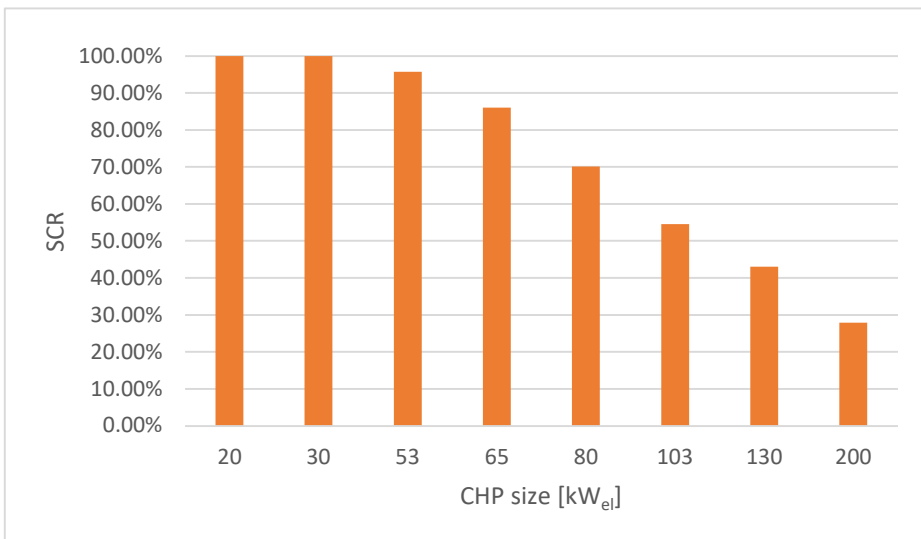

Fig. 13. Self-consumption variation with CHP size increase

4 Conclusion

The aim of this study is to investigate the potential CHP plants integration in the REC and CSC schemes, paying a particular attention to the interchangeability of incentive mechanisms. In detail, it has been evaluated the minimum self-consumption (SC) share needed to even out the revenues coming from the energy efficiency certificates (EECs). In order to establish a SC based tariff for CHP plants, a correlation between SC share and the tariff value has been assessed for different commercial plants. A 70% of SC share has been set as a minimum target, which is related to incentive rates of 53 and 39.5 €/MWh, for mini and micro-CHPs, respectively. A real building and four CHP plants have been considered as reference case studies. A dynamic simulation has been carried out in order to analyse the proposed incentive scheme in a real application. For each scenario, the total full load hours are higher than 3,000 hours per year. Furthermore, a PES value higher than 10% comes out from simulations.

The main findings can be summarized as follows:

- CHP plants can be a viable solution in RECs and CSCs. They are a commercial technology and can guarantee energy and emissions saving. Moreover, its environmental impact can be further reduced in the future, thanks to biofuels and green hydrogen.
- The SC-based tariff may induce to better sizing process and CHP plant management. If the electric SCR is higher than 70%, the total revenues will be more than those obtained with the EECs mechanism. On the contrary, with SCR less than 70%, the revenues will be lower than those related to previous incentive mechanism.
- Furthermore, with the application of SC-based incentive schemes, the revenues are higher for small-size CHP plants. Conversely, under the EECs scheme, more revenues are correlated with a CHP plant oversize and lower SCR.
- Then, the new incentive mechanism can significantly reduce the risks of destabilizing the power grid due to the revenues linked to SCR.

The CHP combination in renewable energy communities' incentive schemes can guarantee energy and emissions savings with an SC-based tariff lower than the current one provided for RES applications in REC and CSC. Furthermore, the actual incentive mechanism for CHP plants appears obsolete if compared with a SC-based tariff. The adoption of this incentive scheme may induce to better sizing process and plants management, minimizing the electricity injection into the power grid. The results of present work can also give insight for policy makers about the convenience of introducing CHP plants in REC and CSC schemes. Moreover, an experimental campaign should be launched in order to obtain a solid dataset to support this foreseeable future integration and to identify the right value of incentive tariff.

Nomenclature

P	Thermal power [kW]
p	Pressure [bar]
\dot{m}	Mass flow rate [kg/s]
T	Temperature [°C]
h	Specific enthalpy [kJ/kg]
ΔT	Temperature difference [°C]
c_p	Specific heat at constant pressure [kJ/kgK]
W	Thermodynamic work [kW]
x	Ammonia molar fraction in liquid phase [% vol.]
y	Ammonia molar fraction in vapour phase [% vol.]
w	Mass fraction [% wt.]
P_{load}	End-user thermal load [kW]
P_{fuel}	Chemical power from fuel [kW]
l_h	Latent heat [kJ/kg]
ρ_n	Normal density [kg/Nm ³]
v	Specific volume [m ³ /kg]
$\epsilon_{exchange}$	Heat exchange efficiency
η_{burner}	Combustion efficiency
λ	Relative Equivalence Ratio
$\eta_{is,pump}$	Pump isentropic efficiency
η_{mech}	Pump mechanical efficiency
α_{st}	Stoichiometric air to fuel ratio
UA	Global heat transfer coefficient [W/K]
Subscripts	

w	Water
in	Inlet
out	Outlet
sat	Saturation
vap	Vapour state
sub	Subcooling
weak	Weak solution
strong	Strong solution
eva	Evaporator
cond	Condenser
rect	Rectifier
gen	Generator
exhaust	Exhaust gases
sol	Solution
Abbreviations and Acronyms	
GUE	Gas Utilization Efficiency
COP	Coefficient of Performance
H ₂ NG	Hydrogen Enriched Natural Gas Blends
HVAC	Heating Ventilation and Air Conditioning
LHV	Lower Heating Value
GAHP	Gas Adsorption Heat Pump

References

- [1] European Parliament and Council of 11 December 2018, “DIRETTIVA (UE) 2018/2001 DEL PARLAMENTO EUROPEO E DEL CONSIGLIO dell’11 dicembre 2018 sulla promozione dell’uso dell’energia da fonti rinnovabili,” *Off. J. Eur. Union*, vol. 2018, p. 128, 2018, [Online]. Available: <https://eur-lex.europa.eu/legal-content/EN/TXT/PDF/?uri=CELEX:32018L2001&from=EN>.
- [2] L. M. Pastore, G. Lo Basso, M. Sforzini, and L. de Santoli, “Heading Towards 100% of Renewable Energy Sources Fraction: a critical overview on Smart Energy Systems planning and flexibility measures,” *E3S Web Conf.*, vol. 197, p. 01003, Oct. 2020, doi: 10.1051/e3sconf/202019701003.
- [3] S. Mokeke and L. Z. Thamae, “The impact of intermittent renewable energy generators on Lesotho national electricity grid,” *Electr. Power Syst. Res.*, vol. 196, p. 107196, Jul. 2021, doi: 10.1016/j.epsr.2021.107196.
- [4] J. Rúa, A. Verheyleweghen, J. Jäschke, and L. O. Nord, “Optimal scheduling of flexible thermal power plants with lifetime enhancement under uncertainty,” *Appl. Therm. Eng.*, vol. 191, p. 116794, Jun. 2021, doi: 10.1016/j.applthermaleng.2021.116794.
- [5] L. Peruzzi, F. Salata, A. de Lieto Vollaro, and R. de Lieto Vollaro, “The reliability of technological systems with high energy efficiency in residential buildings,” *Energy Build.*, vol. 68, pp. 19–24, Jan. 2014, doi: 10.1016/j.enbuild.2013.09.027.
- [6] F. Salata, A. de Lieto Vollaro, R. de Lieto Vollaro, and L. Mancieri, “Method for energy optimization with reliability analysis of a trigeneration and teleheating system on urban scale: A case study,” *Energy Build.*, vol. 86, pp. 118–136, Jan. 2015, doi: 10.1016/j.enbuild.2014.09.056.
- [7] K. Jamaluddin, S. R. Wan Alwi, Z. Abd Manan, K. Hamzah, and J. J. Klemeš, “Performance of Centralised Trigeneration Plant on Sensitivity Analysis of Total Site System,” *IOP Conf. Ser. Mater. Sci. Eng.*, vol. 991, p. 012141, Dec. 2020, doi: 10.1088/1757-899X/991/1/012141.
- [8] T. Korpela, J. Kaivosoja, Y. Majanne, L. Laakkonen, M. Nurmoranta, and M. Vilkkö, “Utilization of District Heating Networks to Provide Flexibility in CHP Production,” *Energy Procedia*, vol. 116, pp. 310–319, Jun. 2017, doi: 10.1016/j.egypro.2017.05.077.
- [9] M. Mysior, P. Stępień, and S. Koziołek, “Modeling and Experimental Validation of Compression and Storage of Raw Biogas,” *Processes*, vol. 8, no. 12, p. 1556, Nov. 2020, doi: 10.3390/pr8121556.
- [10] P. Kolasinski, “Domestic Organic Rankine Cycle-Based Cogeneration Systems as a

- Way to Reduce Dust Emissions in Municipal Heating,” *Energies*, vol. 13, no. 15, p. 3983, Aug. 2020, doi: 10.3390/en13153983.
- [11] T. Asni and V. Andiappan, “Optimal Design of Biomass Combined Heat and Power System Using Fuzzy Multi-Objective Optimisation: Considering System Flexibility, Reliability, and Cost,” *Process Integr. Optim. Sustain.*, vol. 5, no. 2, pp. 207–229, Jun. 2021, doi: 10.1007/s41660-020-00137-4.
- [12] G. Lo Basso, L. de Santoli, A. Albo, and B. Nastasi, “H2NG (hydrogen-natural gas mixtures) effects on energy performances of a condensing micro-CHP (combined heat and power) for residential applications: An expeditious assessment of water condensation and experimental analysis,” *Energy*, vol. 84, pp. 397–418, 2015, doi: 10.1016/j.energy.2015.03.006.
- [13] M. Hemmati *et al.*, “Economic-environmental analysis of combined heat and power-based reconfigurable microgrid integrated with multiple energy storage and demand response program,” *Sustain. Cities Soc.*, vol. 69, p. 102790, Jun. 2021, doi: 10.1016/j.scs.2021.102790.
- [14] P. J. Mago and A. D. Smith, “Evaluation of the potential emissions reductions from the use of CHP systems in different commercial buildings,” *Build. Environ.*, vol. 53, pp. 74–82, Jul. 2012, doi: 10.1016/j.buildenv.2012.01.006.
- [15] G. Lo Basso, F. Rosa, D. Astiaso Garcia, and F. Cumo, “Hybrid systems adoption for lowering historic buildings PFEC (primary fossil energy consumption) - A comparative energy analysis,” *Renew. Energy*, vol. 117, pp. 414–433, 2018, doi: 10.1016/j.renene.2017.10.099.
- [16] G. Fan, M. Li, X. Chen, X. Dong, and K. Jermsittiparsert, “Analysis of a multi-objective hybrid system to generate power in different environmental conditions based on improved the Barnacles Mating Optimizer Algorithm,” *Energy Reports*, vol. 7, pp. 2950–2961, Nov. 2021, doi: 10.1016/j.egy.2021.05.023.
- [17] A. Franco and F. Fantozzi, “Experimental analysis of a self consumption strategy for residential building: The integration of PV system and geothermal heat pump,” *Renew. Energy*, vol. 86, pp. 1075–1085, Feb. 2016, doi: 10.1016/j.renene.2015.09.030.
- [18] H. Fathabadi, “Novel fast and high accuracy maximum power point tracking method for hybrid photovoltaic/fuel cell energy conversion systems,” *Renew. Energy*, vol. 106, pp. 232–242, Jun. 2017, doi: 10.1016/j.renene.2017.01.028.
- [19] M. Sforzini, G. Lo Basso, R. Paiolo, L. De Santoli, and F. Cumo, “Adsorption gas Heat Pump fuelled with hydrogen enriched natural gas blends: the analytical simulation model development and validation,” *E3S Web Conf.*, vol. 197, p. 08002, Oct. 2020, doi: 10.1051/e3sconf/202019708002.

- [20] Z. Liu, W. Xu, X. Zhai, C. Qian, and X. Chen, “Feasibility and performance study of the hybrid ground-source heat pump system for one office building in Chinese heating dominated areas,” *Renew. Energy*, vol. 101, pp. 1131–1140, Feb. 2017, doi: 10.1016/j.renene.2016.10.006.
- [21] D. Chemisana, J. I. Rosell, A. Riverola, and C. Lamnatou, “Experimental performance of a Fresnel-transmission PVT concentrator for building-façade integration,” *Renew. Energy*, vol. 85, pp. 564–572, Jan. 2016, doi: 10.1016/j.renene.2015.07.009.
- [22] G. Graditi *et al.*, “Innovative control logics for a rational utilization of electric loads and air-conditioning systems in a residential building,” *Energy Build.*, vol. 102, pp. 1–17, Sep. 2015, doi: 10.1016/j.enbuild.2015.05.027.
- [23] P. Siano, G. Graditi, M. Atrigna, and A. Piccolo, “Designing and testing decision support and energy management systems for smart homes,” *J. Ambient Intell. Humaniz. Comput.*, vol. 4, no. 6, pp. 651–661, Dec. 2013, doi: 10.1007/s12652-013-0176-9.
- [24] M. Bollen, A. Larsson, and S. Rnnberg, “Grid impact from PV-installations in northern Scandinavia,” in *22nd International Conference and Exhibition on Electricity Distribution (CIRED 2013)*, 2013, pp. 1036–1036, doi: 10.1049/cp.2013.1046.
- [25] L. Ji, X. Liang, Y. Xie, G. Huang, and B. Wang, “Optimal design and sensitivity analysis of the stand-alone hybrid energy system with PV and biomass-CHP for remote villages,” *Energy*, vol. 225, p. 120323, Jun. 2021, doi: 10.1016/j.energy.2021.120323.
- [26] U. Lehtinen, J. Juntunen, and J. Juga, “Evaluating the feasibility of bio-energy based heat and power production in rural community,” *Biomass and Bioenergy*, vol. 139, p. 105578, Aug. 2020, doi: 10.1016/j.biombioe.2020.105578.
- [27] Enea, “Cogenerazione ad alto rendimento, Aggiornamento dell’edizione 1,” no. Vi, pp. 1–18, 2018.