

Improving performance of direct expansion air conditioning systems while reducing electricity consumption through using hybrid energy

Ahmed Al-Okbi^{1,2*}, Yuri Vankov¹, Hakim Kadhim³

¹Kazan State Power Engineering University, Kazan, Russia

²University of Technology, Baghdad 10001, Iraq

³Technical Institute of Al-Diwaniyah, Al-Furat Al-Awsat, Technical University (ATU), Iraq.

Abstract. At the present time, operating hybrid air-conditioning systems that use solar energy to saving electrical energy while improving the performance has become necessary to protect the environment, reduce pollution and emissions caused by using fuels and gases. In Iraq, temperatures reach half the boiling point at summer, therefore the demand for air conditioning systems increases, air conditioning systems consume more than half of average electricity production which affects on reliability and stability of the electrical energy thus leads to a continuous power outage. So, the issue of using renewable energies becomes more attractive. Because of saving energy leads to ensuring the reliability of electricity and reduces the consumption of fuels and gases that pollute on the environment and negatively affect on the ozone layer. In the current research, the atmosphere of Baghdad city was used to collect solar thermal energy and convert it into thermal energy through an evacuated solar collector by water and combine it with a conventional air conditioner in the part that follows the compressor in order to reduce the electrical energy consumption on the compressor and increase coefficient of performance. Several tests were conducted on the proposed system to compare results with the conventional system and evaluate performance. The results showed that the coefficient of performance with the hybrid system became 8.97 more efficient instead of 4.27 compared to the conventional system, and the energy consumption decreased by 52%.

1 Introduction

Due to high temperatures in summer in hot regions such as Iraq, the demand for direct expansion air conditioners of various sizes increases, which means increases the consumption of electrical energy, which in turn affects on the guarantee of its reliability and stability. Where excessive consumption of electrical energy increase gas emissions, fuel consumption, and adversely affects on the environment, life, ozone layer, depletion of fossil fuels and others, which represents a real problem that must be addressed by developing environmentally friendly technologies and saving energy [1-4]. Academic and industrial institutions have become supportive of research interested in employing solar thermal energy to operating air-conditioning systems, as it is one of renewable energies, environmentally sustainable, promising and widely available [5-8]. Among different refrigeration cycles, the DX compression refrigeration cycle is the most commonly used in vehicles, homes and public buildings, being simple in configuration and easier to maintain compared to central cooling systems using a water-cooling tower. Researches continue to improve the performance of DX air conditioners using various solar energy systems to reach the best performance with the lowest energy consumption [9-10]. Li Huang et al. [11] he installed a solar cooling and heating system in Ningbo City, China that composed of

evacuated tube solar collector, LiBr–water-based absorption chiller with a cooling capacity of 35 kW, a cooling tower, a hot water storage tank, a buffer tank, and two air-source heat pumps. To study the effect of solar thermal energy on the system. The results showed that the COP chiller ranged between 0.68 and 0.76 in 2018 and the electricity savings 41.1%. Munaaim M. et al. [12] conducted a comparative study between solar assisted air conditioning and Inverter-type in the northern region of Malaysia, in Kedah where heating, ventilation, and air-conditioning (HVAC) systems consume approximately 55% in buildings. The results showed that the COP for solar air conditioning more than Inverter-type and the power consumption less than the Inverter-type. Al-Ugla et al. In 2016 [13] confirmed that DX air conditioning systems consume about 65% of the electrical energy in the construction sector in Saudi Arabia, and energy savings lie in the use of solar energy. By Fong et al. [15], He studied and compared five different types of solar cooling systems for the subtropical city of Hong Kong with the aim of determining which system was the most energy efficient. It was carried out on the following solar energy cooling systems: a solar electric vapor pressure cooling system, a solar mechanical vapor compression cooling system, a solar absorption cooling system, a solar adsorption cooling system, and a solid solar dryer cooling system. The performance evaluation results showed that the solar

* Corresponding author: ahmedkhaleel18@yahoo.com

stainless copper fins and air-cooled type. The compressor in the outdoor unit with a capacity of 2 tons, rotary type manufactured by ZHUHAI LANDA Company, and in order to benefit from solar energy in high efficiency and reduce the work spent on the compressor, another smaller compressor with a capacity of 1.5 tons from HIGHLY Company was used as shown in Figure 3. The expansion device in the outdoor unit is a capillary tube type. The refrigerant fluid used in the system is R410A and the charge weight is 1.8 kg. The solar collector was directed towards south of Baghdad and at an angle of 45 degrees. The storage thermal tank is thermally insulated with the foam material with a thickness of 5 cm in the form of a horizontal cylinder. Table No. (1) Contains all the details and parts of the test device.

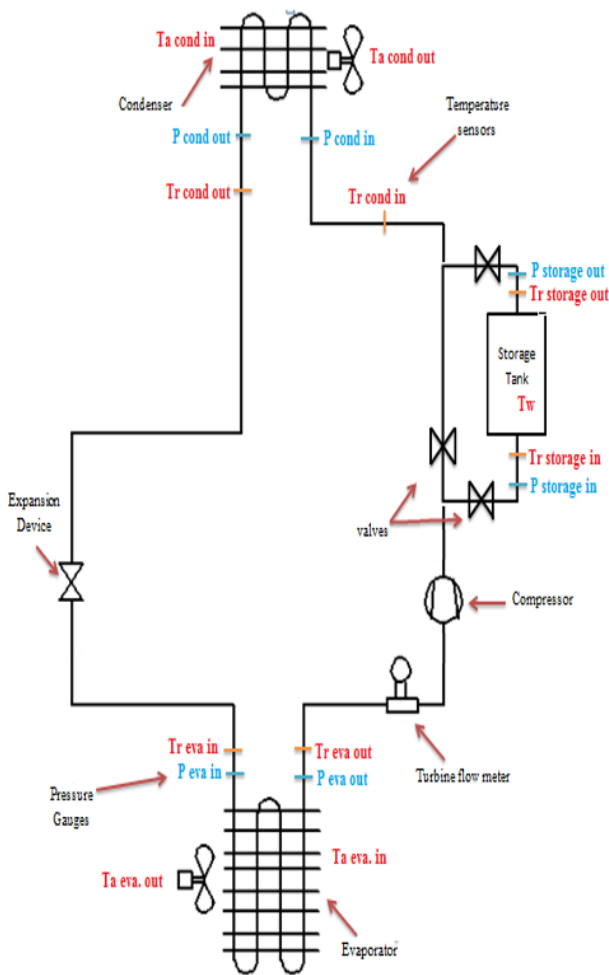

Fig. 2. Schematic diagram for the components of a hybrid air conditioner system.



Fig. 3. Indoor unit with measuring devices, data recorder and laptop.



Fig. 4. The outdoor unit integrated with the solar collector.

Table 1. Specification of hybrid air conditioner system.

Air conditioner split unit model	TS-H246OZM3	
Series	Moon	
Compressor type	Rotary	
Power supply	220 – 240V/ 1 PH/ 50 Hz	
Cooling capacity	24000 (Btu /h)	
Cooling current	10 (A)	
Input Power	2040 – 2180 (W)	
Refrigerant type/ charge	R-410A/1800 (g)	
Expansion Device	capillary tube	
Condenser coil	Copper tubes, aluminum flat fins	
Length of tube	87 (cm)	
Condenser motor fan	Propeller	
Number of tubes	60	
Evaporator coil	Copper tubes, aluminum flat fins	
Length of tube	86 (cm)	
Number of tubes	40	
Air Flow	1250 m ³ /h	
Connection pipes		
Location	Length (cm)	Diameter (in)
Pipe from compressor to tank	115	½

Pipe from tank to condenser	120	½
Pipe from capillary to evaporator	480	¼
Pipe from evaporator to compressor	480	5/8
Storage tank		
Diameter	42 cm	
Length	139 cm	
Storage capacity	120 L	
Collector		
Number of tubes	18	
Inside diameter (cm)	3.7 cm	
Outside diameter (cm)	4.7 cm	
Clearance between tubes	0.5 cm	
Length of tube	150 cm	
Length of tube exposed to the sun (cm)	137 cm	
Coil inside the tank		
coil type	copper	
Shape	Spiral	
diameter	½ "	
Length	80 cm	
cycle diameter	14 cm	
Number of cycle	35 Cycle	
Valves		
Number of valves	3	
type	Gate, copper	
diameter	½ in	

Were used high-precision devices for the purpose of measuring and recording the operating parameters: a digital power meter [UT233] to measure the voltage difference, current, power consumed in the system, phase angle and frequency; a turbine flow meter [SM-15-63] with a display meter was used to measure gas flow rate in the system; thermocouples Type (K) was used and distributed on all parts of the test device to measuring temperatures; data logger (HUATO S220-T8) to record temperatures from (8) thermocouples on a laptop in the form of a Microsoft Excel data sheet with an interval set every three minutes; six pressure gauges Borden type (BTC) was used, two of them low pressure gauges before and after the evaporator and four high pressure gauges before and after the solar thermal collector and condenser; an anemometer [MS6252B] was used to measure the ambient temperature, the relative humidity rate, the speed and the amount of air passing through evaporator and condenser; The VICTOR 1010D digital solar radiation intensity meters was used to measure the rate of solar radiation falling on the test device to find out the rate and amount of thermal energy transferred during the testing hours to the solar thermal collector. All tools and equipment necessary for the purpose of cutting, polishing, expanding, welding, discharging, charging and indicating the weight of the shipment were used for the purpose of operating the device as required. The tester was initially vacuumed with a vacuum pump and checked for leaks, and then the cooling system was charged (1800g) with a refrigerant (R 410A). Continuous field tests were conducted to monitor system performance for 10 hours a day and during rush hour in Baghdad weather conditions, and all

measured data were monitored. Then all measured data were saved for later analysis.

4 results and discussion

After installed and preparation of the test device as required, the device was turned on and after it reached the stability state, the data was recorded on the laptop computer for the required parameters and then the CoolPack package to analyse a data was used to calculate the thermal parameters, the average energy consumption and the cooling capacity. Were compared between three cases to show the effect of the integrated of solar thermal collector with the conventional air conditioner which installed after the compressor and its effect on the coefficient of performance and power consumption of the system. The effect of temperatures with peak hours was consideration on the system.

The test device was operated in three cases by controlling the valves which added after the compressor for the purpose of comparison in terms of coefficient of performance and energy saving rate: the first for a conventional air conditioner with a 2-ton compressor; the second for a hybrid air conditioner which integrated the conventional system with the thermal solar collector and works with a 2-ton compressor; the third for a hybrid air conditioner which integrated the conventional system with the solar thermal collector and operates with a compressor capacity of 1.5 tons. After comparison between the cases the results in Figure 5 showed that the temperatures entering the evaporator for the three cases are almost equal, while the temperatures leaving the condenser at the third case were lower than the first and second cases, and in the second case was less than the first case. The reason behind this is that the rate of heat energy which added to the system by the solar thermal collector raised its temperature and pressure after the compressor and before entering the condenser, which made it easier to condense and lower its temperature faster. Figure 6 showed that the results of comparison between the amount of temperature difference entering and leaving the condenser for the three cases, for the second case is higher than for the first and third cases, and in the third case is higher than the first case, because the condenser will be more efficiency due to the heat which added to the refrigerant through the thermal solar collector raises its temperature and pressure. In Figure 7, the results of comparison between the coefficient of performance for the three cases showed that the highest value of COP for the third case more than second and first cases and in the second case more than first case, the reason behind this in the third case, were used a solar thermal collector and compressor 1.5 ton which reduce power consumption in the compressor and used solar thermal energy which added to refrigerant in the part after compressor which mean solar thermal compressor, and in the second case more than the first due to solar thermal collector reducing the work spent on the compressor. in Figure 8. the results of comparison between power consumption showed that in the third case decreased to 50% less than the first and third cases

due to reducing the compressor size from 2 tons to 1.5 tons for the same parts of the test device.

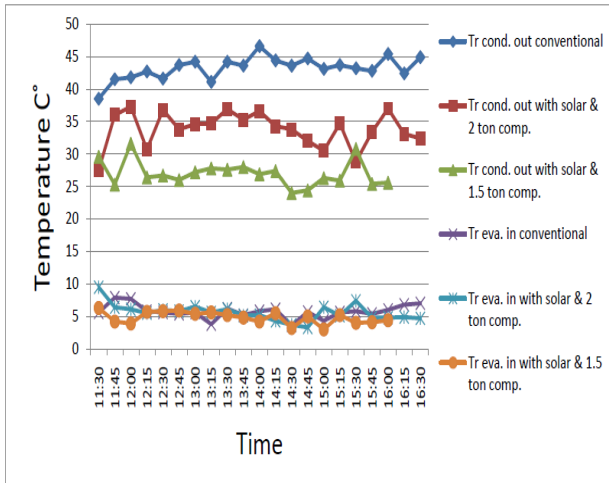

Fig. 5. Temperatures leaving the condenser and entering the evaporator.

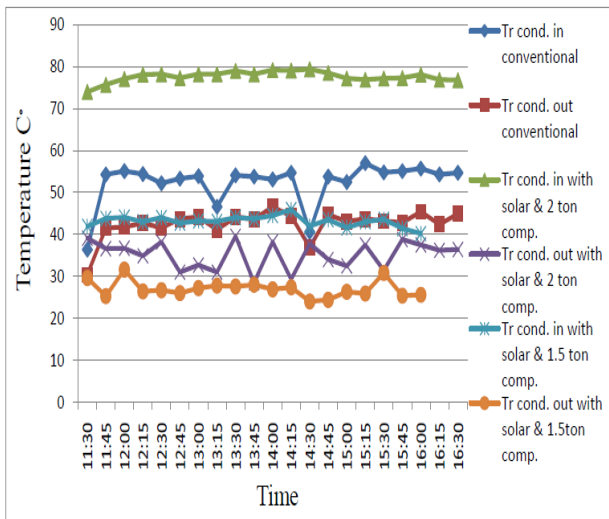

Fig. 6. Temperatures entering and leaving the condenser.

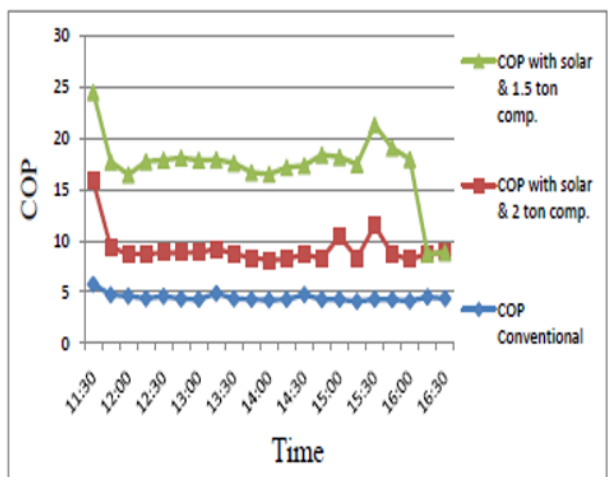

Fig. 7. Coefficient of performance for systems.

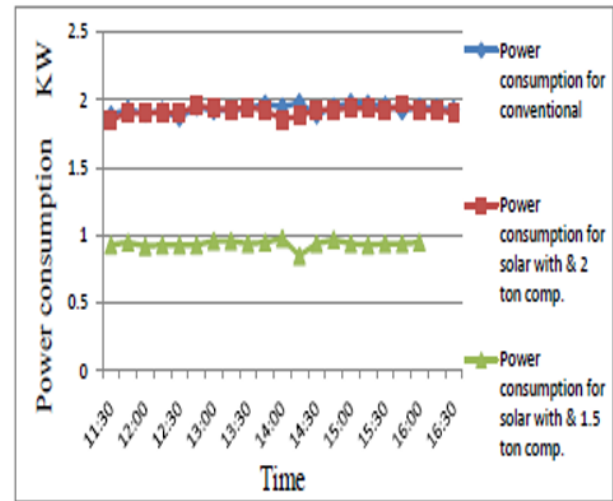

Fig. 8. Power consumption for systems.

5 Conclusions

A practical study was conducted to evaluate the benefit of using renewable solar thermal energy in the atmosphere of city Baghdad in attempt to improving the performance of air conditioners and saving electrical energy. The new proposed design of a hybrid air conditioning system that use solar thermal energy in order to improve the COP and save electric energy, by added a solar thermal collector in the part after the compressor, it is considered one of the modern and environmentally friendly systems. Modern simulators were used to record the variables in the refrigeration cycle for three different cases: the first case for a conventional air conditioner with a compressor capacity 2 ton; the second case combined a conventional air conditioner with a solar thermal collector through valves which added after the compressor and compressor capacity 2 ton; the third case is combined with a solar thermal collector but with a compressor capacity 1.5 ton. The data was recorded on the laptop and then analyzed by coolpack software. The three cases above have been compared to see how useful solar energy. The results showed that the new hybrid air conditioner system saves electrical energy and increase the coefficient of performance compared to the conventional system. Practical results prove that the new design gives COP 9.87 instead of 4.27, which increases COP by 52.5% and reduces energy consumption by 52%.

References

1. Duffie, John A., and William A. Beckman. Solar engineering of thermal processes. John Wiley & Sons, 2013.
2. Y. Vankov, A. Al-Okbi, M. H. Hasanen. "Solar hybrid air conditioning system to use in Iraq to save energy." E3S Web of Conf. EDP Scien. Vol. **124**. 2019.

3. I. Dincer, M. Kanoglu. *Refrigeration systems and applications*. New York : Wiley, Vol. **2**. 2010.
4. Kim, D. S., and CA Infante Ferreira. "Solar refrigeration options—a state-of-the-art review." *International journal of refrigeration* 31.1 (2008): 3-15.
5. Buker, Mahmut Sami, and Saffa B. Riffat. "Building integrated solar thermal collectors—A review." *Renewable and Sustainable Energy Reviews* 51 (2015) : 327-346.
6. Mekhilef, Saidur, Rahman Saidur, and Azadeh Safari. "A review on solar energy use in industries." *Renewable and sustainable energy reviews* 15.4 (2011) : 1777-1790.
7. Allan, James, et al. "Performance testing of thermal and photovoltaic thermal solar collectors." *Energy Science & Engineering* 3.4 (2015) : 310-326.
8. Ahmed Al-Okbi, Yuri Vanko, and Hasanen Mohammad Hussain. "A hybrid air conditioning system using solar energy to save electrical energy with improving performance." *E3S Web of Conf. EDP Scien. Vol. 122*. 2021.
9. Hajjaj, Charaf, et al. "A PVT cooling system design and realization: temperature effect on the PV module performance under real operating conditions." *International Journal of Renewable Energy Research* 13 (2019).
10. A. R. Trott, T. C. Welch, *Refrigeration and air conditioning*. Butterworth-Heinemann, (1999).
11. Huang, Li, Rongyue Zheng, and Udo Piontek. "Installation and operation of a solar cooling and heating system incorporated with air-source heat pumps." *Energies* 12.6 (2019) : 996.
12. Munaaim, M. Arkam C., Karam M. Al-Obaidi, and M. Azizul Abd Rahim. "Performance Comparison of Solar Assisted and Inverter Air-Conditioning Systems in Malaysia." *Journal of Design and Built Environment* (2017) : 53-61.
13. Al-Ugla, A. A., et al. "Techno-economic analysis of solar-assisted air-conditioning systems for commercial buildings in Saudi Arabia." *Renewable and Sustainable Energy Reviews* 54 (2016) : 1301-1310.
14. K. F. Fong, T. T. Chow, C. K. Lee, Z. Lin, L. S. Chan, "Comparative study of different solar cooling systems for buildings in subtropical city." *Solar Energy* **84.2** : 227-244 (2010).
15. Nader, N. A., A. M. Ibrahim, and A. S. Rami. "Hybrid air conditioning, solar, HVAC, energy consumptions." *International Journal of Modern Engineering Research* 6.10 (2016) : 34-32.