

Distributed solar panel heating scheme with auxiliary energy in Tibet

Liqing Zhou ^a

Tibet Autonomous Region Energy Research Demonstration Center, Lasa 850000, China

Abstract. Tibet is located in the high cold and high altitude, the ecological environment is fragile, and the clean utilization of energy has attracted much attention. On the basis of clean energy and reliable power supply, winter heating in Tibet is an urgent livelihood problem to be solved. Based on the current situation of solar heating in Tibet, a distributed solar flat heating scheme with auxiliary energy is proposed, and the heating dispatching mode is analyzed. The research results not only provide a solution for energy efficient and clean heating in Tibet, but also have a certain reference value for the construction of clean energy base in Tibet.

Keywords: Tibet; Multi energy complementarity; Distributed heating; Large flat plate collector

1 Introduction

At present, in addition to cogeneration central heating in cities and towns in Tibet, there are still a large number of small boiler rooms for heating. In rural winter, the main heating is the burning of cow dung by a single household small stove, which has not realized central heating. Low energy efficiency and destruction of ecological environment [1]. Due to the fragile ecological environment in Tibet, the clean utilization of energy has attracted much attention. Tibet is an area of solar energy resources, and solar heating has been preliminarily popularized and applied [2]. As a recognized clean energy, solar energy has gradually become the focus of human development and utilization because of its clean, sustainable, rich source and inexhaustible advantages. Strengthening the application and demonstration of solar heat utilization technology is of far-reaching significance to Tibet in China. However, solar energy has unstable factors such as dispersion, randomness and intermittence. In case of seasonal changes or long-term cloudy and rainy weather, the operation of the heating system is unstable, which limits the development process of solar heat utilization [3]. If solar energy is integrated and coupled with conventional heating technology, develop solar distributed heating system with auxiliary energy, optimize efficient heating equipment, and protect the ecological environment while ensuring heating quality. The analysis shows that using multi energy complementary heating mode to form the heating source in Tibet will effectively improve the comfortable quality of life of green public buildings and residential buildings.

2 Current situation of solar heating

Because most renewable energy sources are unstable and can not provide continuous heating, many scholars and research institutions are discussing how to make better use of renewable energy. The realization of multi energy complementary distributed heating will be one of the effective ways to solve this problem. At present, the complementary utilization of energy mainly includes solar energy and heat pump, solar energy and biomass energy, solar energy and electric cooker [4,5].

2.1 Solar + Heat pump

Solar heat pump is an effective combination of solar heat collection technology and heat pump technology. Solar energy provides the main heat source for the evaporator, and takes the energy improved by heat pump technology as the auxiliary heat source. Cao Wenpu et al.[6] preliminarily analyzed the energy-saving effect of solar hybrid heat pump and obtained that the combination of solar heat pump system and other heat pumps can not only improve the average temperature of heat pump heat source, but also effectively improve the energy utilization rate. However, due to the operation and maintenance of heat pump equipment and other reasons, the operation effect of heating systems such as Tibetan hospitals that have been put into operation is poor.

^a 853969982@qq.com

2.2 Solar + Biomass energy

Biomass solid briquette refers to a kind of solid granular fuel that can be burned directly after crushing agricultural and forestry wastes under a certain temperature and pressure. Its energy flow density is equivalent to the median bituminous coal. There is no CO₂ emission during combustion, and the emissions of NO_x and SO₂ are much lower than that of coal. Biomass has been put into operation as a fuel to provide heating source for residents in Ali Region of Tibet, but it can not be sustained because of the cost. Wang Zelong et al. [7] established the economic analysis model of biomass solar energy system, and used linear programming to optimize the system design parameters, which is suitable for small and medium-sized users; Yuan Shijie et al. [8] established a solar biomass complementary heating system from the perspective of realizing complementary advantages, easy control and ensuring heating continuity and stability, which can operate according to the set control mode through the automatic control unit.

2.3 Solar + Electric boiler

Electric boiler is a kind of boiler that converts electric energy into heat energy and transmits steam, high-temperature water or organic heat carrier to the outside in the form of boiler. Liu Xinyu [9] studied the optimization design of the performance of the combined solar and electric boiler heating system. By establishing the dynamic mathematical model of each component and using MATLAB programming software to simulate and analyze, the operation characteristics in the heating season are obtained; Feng Junzhi [10] analyzed the complementary system of solar heat pump and electric boiler in Lanzhou, and discussed the heating capacity of each part of the complementary heating system in the heating season under different guarantee rates of solar collectors. This heating method is suitable for areas with reliable power supply.

3 Solar collector and auxiliary heat source

Combined with the advantages of abundant solar energy resources in Lhasa, taking natural gas as the auxiliary heat source to better meet the needs of residents for heating and domestic hot water, this paper puts forward a distributed multi energy complementary coalless heating system scheme with auxiliary energy, and discusses the solar heat utilization technology and the process of natural gas integration.

3.1 Large flat plate collector

At present, vacuum tube collectors are usually used in many areas. Although this scheme saves operation cost and protects the environment, the vacuum tube collectors used have some disadvantages, such as fragile, easy to damage, high maintenance cost and difficult to transport and install; At the same time, it has no overheating protection function and poor frost resistance. It cannot be used normally below - 20 °C; The glass tube gap is large,

the unit effective heat collection area is small, the heat gain is low, and it needs to occupy more building space. Therefore, the high-efficiency large flat plate collector is selected for the heating system in this paper, as shown in Figure 1. The basic size is 5920mm×2224mm×130mm. The antifreeze heat transfer medium is used to collect heat. Under the irradiation of sunlight, the light energy is converted into heat energy, and then the heat is transferred to the cold water through the plate heat exchanger to gradually increase the temperature of the cold water.



Fig.1 High efficiency large flat plate collector

The high-efficiency large flat plate collector of Tianpu New Energy Technology Co., Ltd. is selected for the system, which not only makes up for the deficiency of vacuum collector tube, but also has the following main advantages compared with ordinary small flat plate collector:

- The flat plate collector designed in cooperation with Senzo company of Spain adopts imported blue film, with an absorption ratio of 0.94 (national standard requirement ≥ 0.92) and an emissivity of 0.033 (national standard requirement ≤ 0.2);
- High permeability and low iron cloth tempered glass is adopted, with light transmittance $\geq 95\%$; The instantaneous efficiency can reach 0.80, the heat absorption is fast, the thermal efficiency is increased by more than 20%, and the thermal performance is higher;
- Ultra thick insulation is adopted, with small heat loss, which is better than the national standard by 25%, meeting the requirements of efficient heat collection under different working conditions. The heat lasts for a long time, and the air drying temperature can reach 208 °C;
- It adopts natural color ultra-high strength aluminum alloy frame, which is corrosion-resistant;
- The heat collecting area of a single block is greater than 12m², which reduces the relative surface area per unit area and reduces the heat loss;
- High system safety: the single collector forms an array, removes the connection between small collectors, has reliable sealing and high safety performance;
- Integrated design of heat absorption channel, less welding, corrosion resistance and high safety performance.

3.2 Auxiliary heat source

Common auxiliary heat sources of solar heating system include coal-fired boiler, oil fired boiler, gas wall mounted boiler, electric boiler, air or water source heat pump, biomass boiler, etc. As a traditional heating method, coal-fired boiler and oil-fired boiler have a long development time and high technical level, but they are

unfavorable to the ecological environment. Although biomass boilers can effectively reduce energy consumption and environmental pollution, their use is relatively limited due to short development time, relatively low technical level of equipment and poor adjustability. Combined with the geographical location, resource distribution and environmental protection of Tibet, the gas wall mounted furnace is adopted in the heating scheme. Due to the low energy flow density of solar energy and inconvenient storage, it can only be stored and utilized in other forms. The complementary application of gas wall mounted furnace and solar heat collection technology can alleviate the shortage of natural gas resources.

4 Integration of solar distributed heating system with auxiliary energy

Take the office building of the energy research and demonstration center of Tibet Autonomous Region as an example. The office building is a three storey building facing north and south, with a heating area of 570m². Usually, it only needs heating during the day. At present, the solar distributed heating system with auxiliary energy has been applied in office buildings, and the preliminary heating relying on solar energy as a single heat source has been realized. The heating effect is ideal, and the room temperature of each room in the office building can reach the design temperature.

4.1 Heating system

The solar distributed heating system with auxiliary energy takes solar energy as the main heat source and gas as the auxiliary heat source. Natural gas can provide heat source support for the system when solar energy does not meet the demand. It is the best coupling mode of solar energy and gas. At the same time, the heat storage tank can not only overcome the shortcomings of solar energy, but also reduce conventional energy consumption and protect the environment. The working principle of the system is shown in Figure 2.

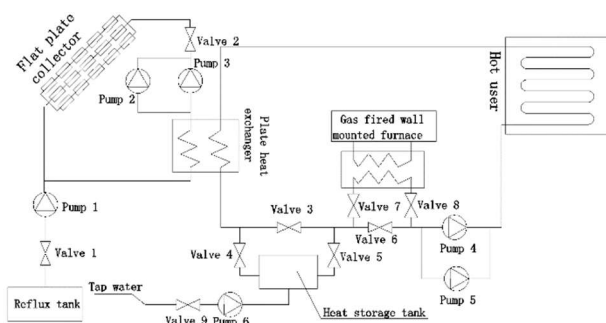

Fig.2 Solar distributed heating system with supplementary combustion

4.2 Multimodal analysis

The solar distributed heating system with auxiliary energy can be controlled by full-automatic heating mode and manual heating mode. Among them, the manual heating mode includes the following four types:

- Full solar heating mode. Using the temperature difference control mode, when the solar energy is sufficient, the solar system provides heat for heat users for direct heating; When the room temperature is higher than the maximum limit, too much heat is collected. At this time, the excess heat will be stored in the heat storage tank. The gas wall mounted furnace does not work and there is no fossil energy consumption;
- Dual energy coupled heating mode. When the solar energy is reduced and the room temperature is lower than the set value, the solar energy cannot meet the needs of residents, and the heat storage tank will provide heat. If it still cannot meet the needs, start the gas wall mounted furnace to increase the heating water temperature to the set value;
- Full wall mounted boiler heating mode. When the room temperature is lower than the minimum limit, it will no longer exchange heat with the solar heat collection system, and the heat of the system will be provided by the gas wall mounted furnace;
- Anti freezing mode of solar collector. When heating is not required at night or in low-temperature weather, in order to prevent the flat plate collector from freezing and cracking, only the heat transfer medium in the solar heat collection system circulates to achieve the purpose of protecting the heat collection system.

For the solar distributed heating system with auxiliary energy, multi-mode joint control is adopted, and remote monitoring can be carried out through mobile app; The heat collection system adopts high-efficiency large flat plate collector, and the installation angle can be adjusted to maximize the use of solar energy and improve the heat collection efficiency. Under the condition of ensuring the heating quality, make full use of clean energy, optimize its control and operation methods, and increase the economy of the heating system.

5 Conclusion

- The solar large flat plate heating system with auxiliary energy has simple structure and convenient operation. It adopts multi-mode joint control and remote monitoring through mobile App. The heat collection system adopts high-efficiency large flat plate collector to make maximum use of solar energy and improve the solar energy guarantee rate of the heating system. It can adapt to the heating environment under a variety of complex working conditions and realize clean heating in Tibet.
- Improving the quality of urban heating is one of the key issues to improve people's livelihood. Through the research on a solar distributed heating system with auxiliary energy and its optimal control method, under the condition of ensuring the heating quality, make full use of clean energy, reduce the energy consumption such as natural gas in the heating period, reduce the cost and protect the ecological environment.

References

1. Wang Xiaofeng, CIREN pingcuo, Wang junle. Some thoughts on the utilization of renewable energy in Tibet [J]. Tibet Science and technology, 2006 (8): 13-16.
2. Jin Hongguang, Sui Jun. heat utilization and comprehensive utilization of renewable energy [J]. Journal of the Chinese Academy of Sciences, 2016 (2): 208-215.
3. Li Zhongyi. Analysis on the development trend of solar thermal utilization technology [J]. Resource conservation and environmental protection, 2014 (8): 32-33.
4. Liu lifeI, Luo Huilong, Tian Panyu, et al. Heat utilization analysis based on solar cogeneration [J]. Low temperature building technology, 2016 (11): 134-136.
5. Chen Chen. Research and application of optimal design of solar heating system [D]. Shijiazhuang: Shijiazhuang Railway University, 2013.
6. Cao Wenpu, Li Haiying, Zhang Yan, et al. Energy saving effect analysis of solar hybrid heat pump [J]. Applied energy technology, 2016 (6): 41-44.
7. Wang Zelong, Tian Yishui, Zhao Lixin, et al. Optimal design of biomass solar complementary heating system [J]. Journal of agricultural engineering, 2012,28 (19): 178-184.
8. Yuan Shijie, Wu yunyun, Lu Shihua. Research on heating system based on combined application of solar hot water and biomass energy [J]. Urban development research, 2015,22 (1): 1-3.
9. Liu Xinyu. Study on the performance of solar energy and electric boiler combined heating system [D]. Beijing: North China Electric Power University, 2016.
10. Feng Junzhi. Analysis of combined operation system of solar heat pump and electric boiler in Lanzhou [D]. Harbin: Harbin Engineering University, 2010.