

Additional electric loss in rural distribution networks 0.38 kV

Igor Naumov^{1,2*}, Dmitriy Karamov^{1,3}, Alexander Tretyakov², Elvira Fedorinova² and Marina Yakupova²

¹ Irkutsk National Research Technical University, 83, Lermontov street, Irkutsk, 664074, Russia

² Irkutsk State Agrarian University named after A.A. Ezhevsky, 1/1, Molodezhnaya Street, Irkutsk district Molodezhny settlement, 664038, Russia

³ Melentiev Energy Systems Institute of Siberian Branch of the Russian Academy of Science, 130, Lermontov street, Irkutsk, 664033, Russia

Abstract. The article presents calculations the additional electric loss in the case of three-phase voltage system unbalance in the real rural electrical distribution networks (0.38 kV). Measurements were carried out at substations that receive power from distribution substation "Petrovsk". Measurements were carried out using a certified device "Resource-UF2M". Also presented are graphs of changes in currents/voltages of the negative-sequence and zero-sequence, electric loss and other parameters. The results of the economic assessment of electricity losses are presented. As a result, the proposed method for reducing the power loss factor, that can reduce the losses of electricity.

Keywords. Rural electrical distribution networks, power loss, power loss coefficient, shunt-symmetric device, automatic control system.

1 Introduction

Rural electrical distribution networks (0.38 kV) are characterized by an unbalance distribution of phase currents in a three-phase system. Consequently, the power quality deteriorates and additional electric loss increase. The article [1] presents the results of the influence of voltage unbalance on the operating modes of motors with open and closed slots. Variations in the negative-sequence impedance are related with the structural characteristics of the rotor. The impedance of rotors with closed slots grows considerably when the load is less than rated, producing lower negative-sequence currents and lower losses. Increased rotor impedance in closed slot motors protects these motors against problems due to unbalanced supply voltage. For both type of rotors, we analyse motor derating factor based on voltage unbalance and increases in total losses and rotor losses. For both types of rotors, the authors analysed the derating factor of the motor based on the voltage imbalance and the increase in total losses and losses in the rotor.

Investigation [2] focuses on the performance and energy conversion process of cascaded induction motors operated under balanced and unbalanced conditions. The impacts of both unbalanced voltage and unrated frequency on maximum and steady-state torque, power factor, input active and reactive powers, stator and rotor copper losses, and total harmonic distortion in voltage and current, have been investigated through a simulated model created using Matlab/Simulink software.

In [3] describes the effect of plug-in electric vehicles on network voltage unbalance is investigated in the form of optimization problem. Voltage unbalanced function is

minimized as an objective function in different conditions, subject to network security and plug-in electric vehicles constraints, using particle swarm optimization algorithm. Voltage unbalanced function is minimized by optimally selecting the state of plug-in electric (charging or discharging), plug-in electric point of connection (phase a , b or c) and charging/discharging rating power. Also, the impact of uncoordinated and coordinated charging of plug-in electric on voltage unbalanced function is evaluated. Besides, the effectiveness of the proposed framework is studied based on an unbalanced three-phase distribution network. Finally, the obtained results show that coordinated charging/discharging of plug-in electric can significantly improve voltage unbalanced function value. Paper [4] proposes cost-effective solutions to address the problem of voltage regulation and compensation of the unbalancing effect of single wire earth return lines on the three-phase feeder of these lines, which have been exacerbated by this load growth. To improve the voltage regulation problem, a LV switchable reactor has been designed, a prototype made and tested in the field. Also, an unbalance compensator has been designed to reduce the unbalancing effect of single wire earth return lines. Two case networks have been used to perform simulation studies on the effectiveness of both proposed solutions. At first, a case study is used to demonstrate the impact of a switchable reactor on improving voltage regulation. Then, another case study shows that installation of a switchable reactor and an unbalance compensator simultaneously on a single wire earth return distribution system effectively improves voltage regulation and reduces unbalancing effects.

* Corresponding author: professornaumov@list.ru

[5] describes an allocation methodology for capacitor placement in unbalanced distribution systems to achieve loss minimization with an adequate voltage profile. Switched capacitor banks and/or fixed banks can be allocated on a per-phase or multi-phase, discrete basis, and this allows consideration of the actual unbalanced characteristics of distribution systems. While most methods available in the literature address some specific network loading conditions, e.g. average, light-load or heavy-load, the proposed algorithm is based on the daily load variation curve. The method consists of two main steps: (i) reactive power demand calculation to achieve loss minimization; (ii) discrete capacitor placement. The method is applied on the IEEE 4-bus, IEEE 123-bus and IEEE NEV Test Feeders as well as on an 85-bus feeder. Several alternative allocations are calculated and comparisons with results available in the literature are presented.

Aim of the study: to show, how exactly the losses of electrical energy in real rural electrical distribution networks change with the unbalance of the three-phase voltage system.

2 Posing the question

The following questions were considered as the objectives of the study:

1. Measurement the phase currents in rural electrical distribution networks with a certified device.
2. Calculate and analyse the relevant indicators to determine additional electricity losses and the cost of these losses.
3. Offer recommendations to reduce these losses.

Research has been carried out at substations receiving power from the distribution substation "Petrovavlovsk". Distribution substation, which consists of two busbar sections, to which eight transformer substations are connected. The transformer substations (10/0,4 kV) are evenly distributed, four for each busbar section. The total length of power distribution lines (0,38 kV) from transformer substations to consumers is 4,91 kilometers. A total of nineteen outgoing lines that are equipped with a self-supporting insulated wire that has a wire cross-section of 50 mm².

In the period from August 17 to December 17, 2019, phase currents were measured on all outgoing lines (0,38 kV). The measurements were carried out in accordance with the regulations in force in the territory of the Russian Federation. Measurements were carried out using a certified device "Resource-UF2M"

Calculation of additional electric losses caused by changes in the current unbalance, calculated according to the technique proposed by Professor Fedor Dmitievich Kosoukhov [5]. This technique was implemented in the program "Unbalance".

3 Results

As a result of the performed measurements and calculations, the following were obtained. The average value of the currents in the phases of rural electrical

distribution networks was: phase "A" - 44.60 A, phase "B" - 14.62 A, phase "C" - 17.41 A – Fig. A.1 and 2.

Analysis of the results (Fig. A.3) showed that the average value of the power loss factor was 2.3. Thus, the real losses of electrical energy due to the unbalance of phase currents can be determined by the following formula:

$$\Delta W = (I_A^2 + I_B^2 + I_C^2) \cdot r_0 \cdot l \cdot T, \quad (1)$$

where r_0 - specific active resistance of the phase conductor, Ohm/km; l - length of power distribution lines, km; T - experiment time, hours.

Therefore, the average power loss is 7890 Watt (7,89 kW). If the existing level of phase current unbalance remains unchanged throughout the year, then the electric loss will be: 69116 kW·h. In the case of complete balancing of the operating mode of rural electrical distribution network, the annual electrical losses will be: 30050 kW·h. Accordingly, the annual reduction in electrical losses will be: 39066 kW·h. Now, the cost of electricity for rural areas of the Irkutsk region is 1.17 rubles/kWh, the cost of energy saved for the year would be: 45708 rubles.

Many articles have proven that it is possible to achieve a full balancing mode, in which the power loss factor is equal to 1, is possible only with the help of specialized, balancing devices. These devices have minimal resistance to zero sequence currents, and are able not only to reduce additional losses of electrical energy due to the unbalanced of phase currents, but also to normalize the quality of electrical energy, due to artificial neutral bias, which minimizes the zero sequence of voltage.

A balancing device for three-phase networks with a neutral wire consists of three three-phase electromagnetic devices, the windings of which are connected according to a counter-zigzag scheme, having three phase outputs and one neutral, and each phase output is intended to be connected to the phase wires of the network, and the neutral one - to the neutral wire. Each three-phase electromagnetic device forms one power level of the balancing device.

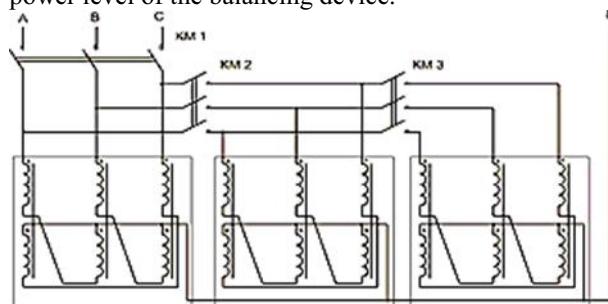

Fig. 1. Balancing device diagram

At the first stage, the first three-phase electromagnetic device is connected. With increasing unbalance of currents and voltages, the power of the device increases. This is achieved by connecting additional one or two three-phase electromagnetic devices to the electrical network.

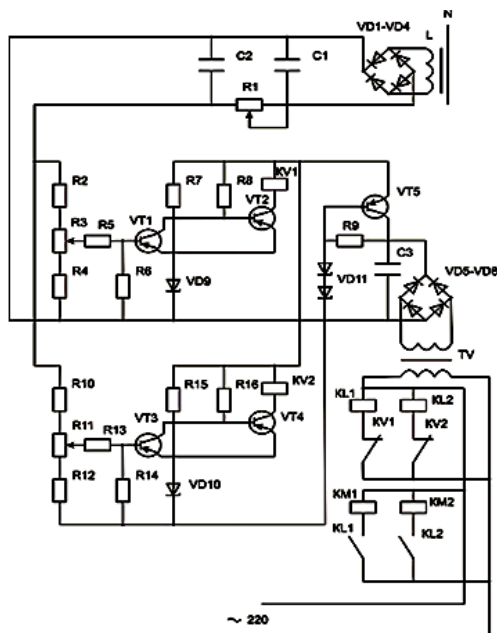

Fig. 2. Balancing device control circuit
 The proposed device is completely disconnected from the network when the current in the neutral wire reaches the minimum value corresponding to the permissible value of the unbalance of currents and voltages.

4 Conclusions

1. In rural electrical distribution networks (0.38 kV), there is a significant asymmetry of phase currents, which

leads to an increase in electricity losses by more than 2 times. For the conditions of the Irkutsk region, the coefficient of additional losses averaged 2.3.
 2. The most effective way to reduce additional electrical losses is a balancing device.
 3. The distribution substation "Petropavlovsk" and the transformer substations receiving power from it were considered as an example. The results showed that the use of a balancing device can more than halve electrical losses. The total cost of savings is more than 45 thousand rubles.

References

1. P. Donolo, G. Bossio, C.D. Angelo. *Energy Convers. Manag.* **52** (2011)
2. E. El-Kharashi, J.G. Massoud, M.A. Al-Ahmar. *Energy*, **181** (2019)
3. H.F. Farahani. *J. Clean. Prod.* **148** (2017)
4. N. Hosseinzadeh, J.E. Mayer, P.J. Wolfs. *Int. J. Electr. Power Energy Syst.* **33** (2011)
5. L.R. De Araujo, D.R.R. Penido, S. Carneiro Jr, J.L.R. Pereira. *Electr. Power Syst. Res.* **154** (2018)
6. Kosouhov F.D., Naumov I.V. *Voltage and current unbalance in rural distribution networks. Irkutsk, "IDP"*, P. 259

Appendix "A" - Measurement results

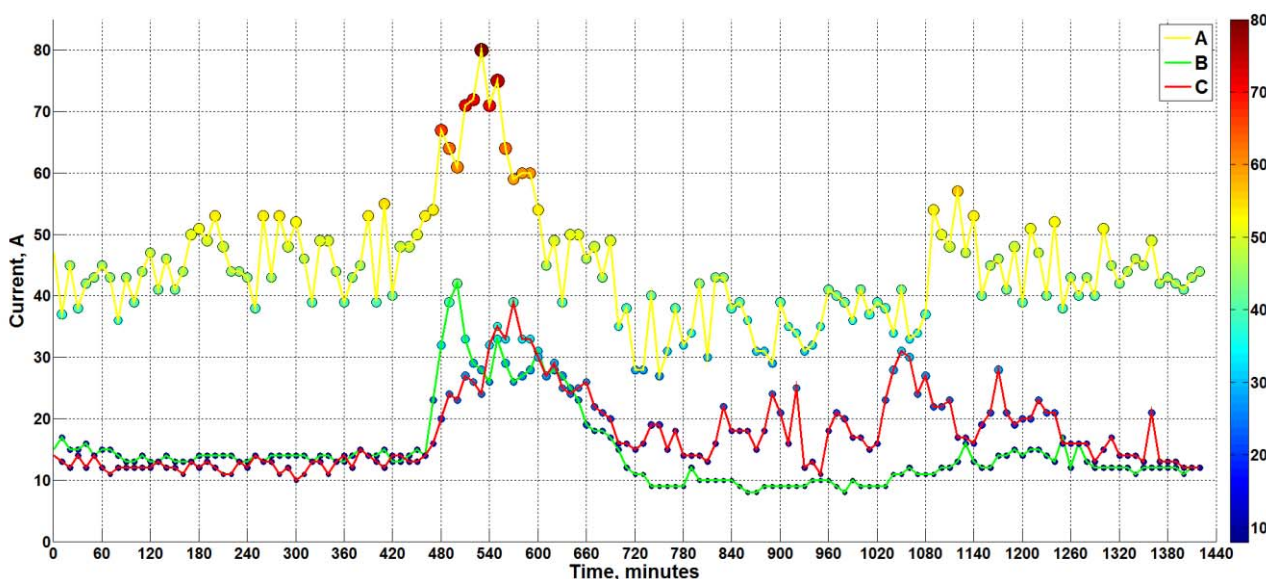

Fig. A.1. Dynamics of average values of currents (phase – A, B, C) in lines (0,38 kV).

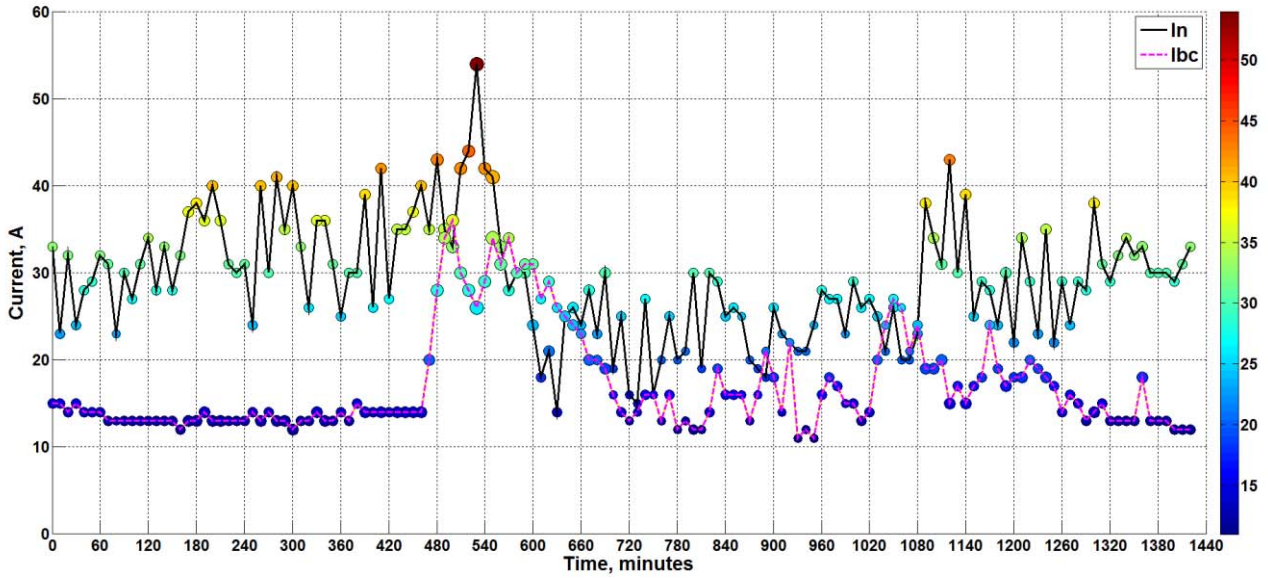

Fig. A.2. Dynamics of average values of currents.

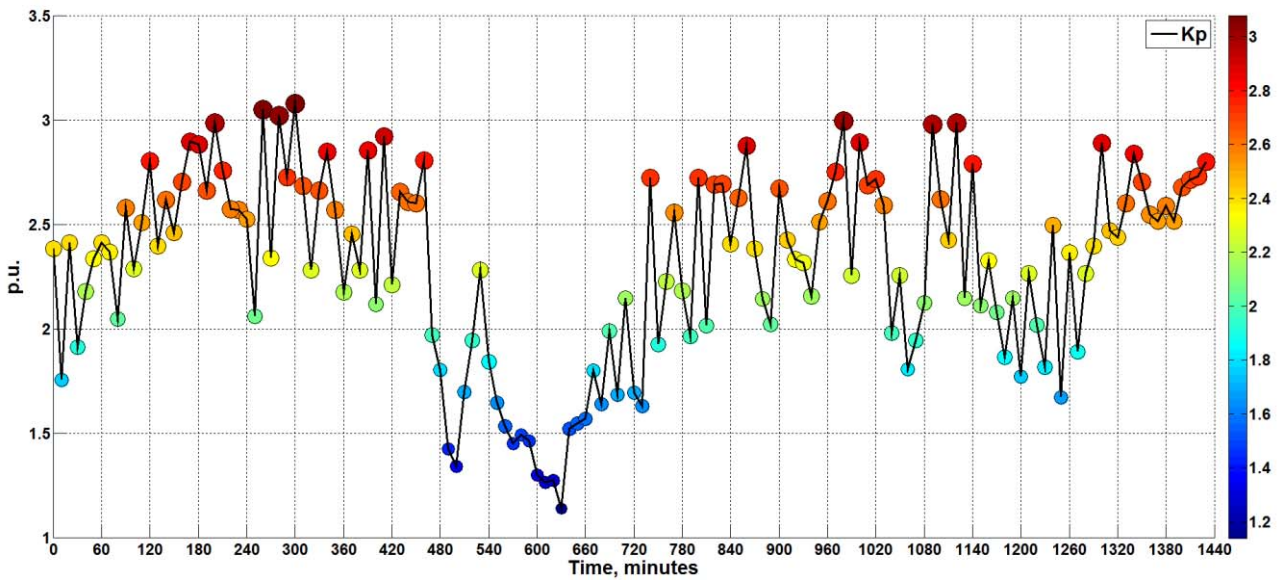

Fig. A.3. Dynamics of average values of power loss factor.

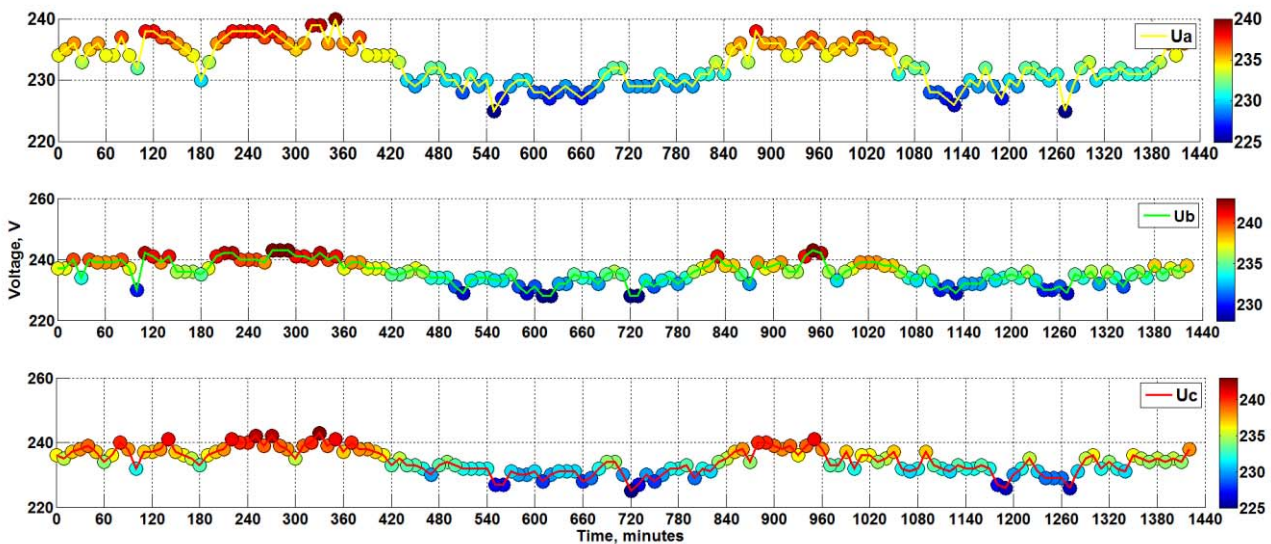

Fig. A.4. Dynamics of average values of voltages (phase – A, B, C) in lines (0,38 kV).