

An option for integration of Carnot Battery into a small Nuclear Power Plant

Ana Borissova¹ and Dimityr Popov^{1,*}

¹Technical University-Sofia 1000, 8 Kl. Ohridski Blvd, Bulgaria

Abstract. This article proposes a combination of nuclear power plant and grid-scale energy storage, classified as Carnot battery. The electric heater heats molten salts when excess electricity is available in the grid. The steam that is produced in a small modular nuclear reactor is heated with hot molten salts in the external super-heater. For continuous superheating to be ensured, the plant is equipped with molten salt thermal energy storage. The combined plant and reference NPP are modelled and simulated at steady-state conditions. Due to the higher turbine inlet temperature, the efficiency of the combined generation-storage nuclear plant is substantially improved. The proposed concept makes the co-location of NPP and Carnot Battery more attractive than the separate plants. The integrated thermal storage acts as secondary electricity storage. As such, it surpasses compressed air storage and is competitive with the pumped hydro storage, in the absence of their geographical and environmental constraints.

1 Introduction

Climate change predictions reveal global warming increasing nearly linearly with cumulative carbon emissions. Renewable energy sources have a fundamental role to play in decreasing our society's carbon footprint. Renewable capacity additions need to evolve by over 300 GW generally each year between 2018 and 2030 to attain the goals of the Paris Agreement, according to the IEA's Sustainable Development Scenario (SDS) [1].

At the end of 2018, worldwide renewable generation capacity totalled to 2 351 GW. Hydro energy answered for the most significant portion of the global total, with an installed volume of 1 172 GW. Wind and solar power generation accounted for most of the rest, with total capacities of 1050 GW. Other renewables included 115 GW of bioenergy, 13 GW of geothermal energy, and 500 MW of marine energy (tide, wave, and ocean energy) [2].

More significant penetrations of intermittent renewable energy can be facilitated by efficient and grid-scale energy storage. The current status of storage technologies is unsatisfactory yet. Despite the extensive research and development works, there are still only two proven technologies for grid-scale energy storage: pumped hydroelectric energy storage and compressed air energy storage [3]. However, the appropriate sites for their location are few due to inherent geological limitations. Pumped hydroelectric energy storage is considered to be a technology with high round trip efficiency reaching the values of 64 to

* Corresponding author: dpopov@tu-sofia.bg

80% depending on the technical characteristics of their equipment. The round-trip efficiency of the Compressed Air storage is much lower, approaching 54% [4].

Two new promising storage technologies have begun to attract policymakers and energy professionals' attention recently: Lithium-ion batteries and Carnot Batteries.

Originating from the electric vehicle sector, Li-ion batteries have also been deployed in a wide range of energy-storage applications, ranging from energy-type batteries of a few kilowatt-hours in residential systems with rooftop photovoltaic arrays to multi-megawatt containerized batteries for the provision of ancillary grid services.

The vast majority of newly added energy storage capacity in 2016 was lithium-ion batteries. Other batteries like redox flow or lead-acid amounted to an estimated 5% of capacity additions, with all other storage technologies combined accounting for the remaining 5% [5]. Lithium-ion battery energy storage has seen remarkable growth in the USA recently. According to USA Energy Information Administration, operating utility-scale battery storage power capacity has more than quadruplicated from the end of 2014 (214 MW) till March 2019 (899 MW). Assuming currently projected extensions are completed, and no current operating capacity is retired, utility-scale battery storage power capacity could exceed 2,500 MW by 2023 [6]. Li-ion batteries are attractive because they provide high round trip efficiency, high energy density, high specific power, long cycle life, and, most importantly, falling specific costs. As a result, for storage durations of 30 minutes to three hours, lithium batteries are currently the most cost-effective solution for the replacement of gas-fired peaking power plants.

On the negative side, several disadvantages can be mentioned, including transportation restrictions, constrained resource supply (lithium and cobalt), still high costs, limited recycling infrastructure, and balance-of-plant requirements —the last of which restricts the energy density of Li-ion stacks [7]. Additionally, lithium-ion batteries present safety concerns. If the battery is short-circuited or exposed to high temperature, exothermic reactions can be initiated, resulting in a self-enhanced increasing temperature loop known as “thermal runaway” that can lead to battery fires and explosions [8].

Carnot Batteries are announced as an emerging and promising technology for the low cost, site-independent, medium-to-large scale and environmentally-friendly storage of electricity. The Carnot Batteries transform electricity into heat, storage the heat in suitable storage media, and transforms the heat back to electricity when required. As the energy conversions are based on thermodynamic cycles originated from classical thermodynamic Carnot cycle, this storage technology is named Carnot battery, although this is not an electrochemical battery. According to Geyer and Freund, by 2017, there were more molten salts-based Carnot-Batteries than electrochemical Batteries [9]. The presented figures include all concentrated solar power plants with molten salt thermal energy storage located worldwide. Carnot batteries can allow coal plants to be converted into storage plants by retrofit with molten salt thermal storage systems, replacing coal-fired boilers.

An intrinsic disadvantage of this storage technology is its low roundtrip efficiency. As it originates from CSP with a steam Rankine cycle power block, the storage efficiency is about 40 % [9]. Stevanovic analysed a Bryton cycle-based system which uses electrical heaters to convert electricity into heat [10]. It is then stored as sensible heat in pebbles. An air turbine with an inlet temperature of 1100 °C is used to convert the heat back into electricity. Because the main components in the system are well established (e.g., electrical heaters, gas turbine, pebble storage), such a system is feasible for the near term. However, the reported roundtrip efficiency is about 40% with the current technology and may reach 54.5% after numerous and challenging improvements. Meroueh and Chen have studied the Carnot battery that represents electrically charged thermal energy storage coupled to a supercritical steam Rankine cycle [11]. They apply unique high-temperature heat storage through the phase change of solid to molten silicon to achieve supercritical steam conditions. Their analysis

shows a storage system cost of $\$45 \pm 10$ per kWh and a 12-hr round-trip efficiency of ~38% - 43%. Substantial increase of Carnot Battery round-trip efficiency is expected to be achieved through the substitution of a resistance heating with a heat pump [9]. Thess has analysed pumped heat electricity storage theoretically [12]. In his models, both charging and discharging cycles are Carnot cycles. Thess has predicted that for storage temperatures at about 400 °C pumped heat electricity storage has a higher efficiency than existing CAES. Laughlin also implemented heat pumps in a grid storage technology that uses molten solar salt at 565 °C as a storage medium [14]. His storage system is based on closed-cycle Brayton engine transfers of heat from a cryogenic storage fluid to molten solar salt. The expected round-trip efficiency is found to be competitive with that of pumped hydroelectric energy storage. The practical implementation of the proposed pumped thermal grid storage is still uncertain as the developers have to overcome several challenges related to the manufacturing of custom air turbines, compressors, and affordable large heat exchangers [13].

Most of the studies mentioned above and projects implementing Carnot batteries rely on well known thermal power plant configurations with steam turbines or gas turbines.

The objective of the presented study was a proper and feasible integration of the Carnot Battery into the small Nuclear Power Plant by implementing mature technologies and components. The main idea is stored thermal energy to be used for nuclear steam superheating. In this way, the innovative and specific configuration of generation-integrated energy storage should be proposed. The primary purpose is to examine its feasibility for short term practical implementation and analysing its round-trip efficiency. The next section conceptually builds up the appropriate plant structure. Section 3 shows the simulation models and hypotheses. Finally, results are discussed in Section 4. A brief economic analysis is presented in section 5.

2 System design

2.1 Nuclear Island

The proposed system incorporates the Pressurised Water Reactor (PWR). This is the most common reactor class, with over 250 units in use for power generation and several hundred more employed for naval propulsion. PWRs use water as coolant and as well as moderator. The primary coolant (water) is injected under high pressure to the reactor core, where it becomes hot by the energy produced by the fission of atoms. The heated water then runs out to a steam generator where it transfers its thermal energy to a secondary circuit where steam is generated and flows to turbines that, in turn, spin an electric generator. In large power plants, the primary circuit consists of separately located reactor pressure vessel (RPV), steam generators, pumps, and pressurizer along with connecting pipes.

The installed capacity of a single unit has increased over the years, due to the broad economy in scale. Today, there is an upswing of interest towards much smaller and simpler units. Some researchers qualify these reactors as the next nuclear frontier [14]. The reason is that they suggest plenty of innovations and distinct advantages. Small modular reactor (SMR) plants offer a simplified, standardized, and safer modular design with inherent passive safety [15]. They are factory built and have a shorter construction period. They can also be realized as a multi-module configuration for a larger output power plant.

Most of the current small modular reactor designs have an integral structure. In integral reactors, the primary coolant system components, including steam generators, pressurizers, and pumps, are contained within the RPV. The integral configuration allows for the elimination of external piping and components, adoption of a compact containment, and reduces NPP dimensions.

For this study, NuScale, SMR, is selected. This is a typical small PWR with an integral design [16]. It is at the very advanced stage of development as all major components and design concepts have been tested. This reactor is operated under natural circulation primary flow conditions. As a result, reactor coolant pumps are eliminated. The steam generator of NuScale is a helical-coil, the once-through heat exchanger positioned in the annular space amid the hot leg riser and the reactor vessel's internal wall. Feedwater is put into the tubes at the bottom and slightly superheated steam exits at the top. Each reactor is housed within its high-pressure containment vessel that is submerged underwater in a stainless steel lined concrete pool. Figure 1 shows the assumed NuScale single module plant layout.

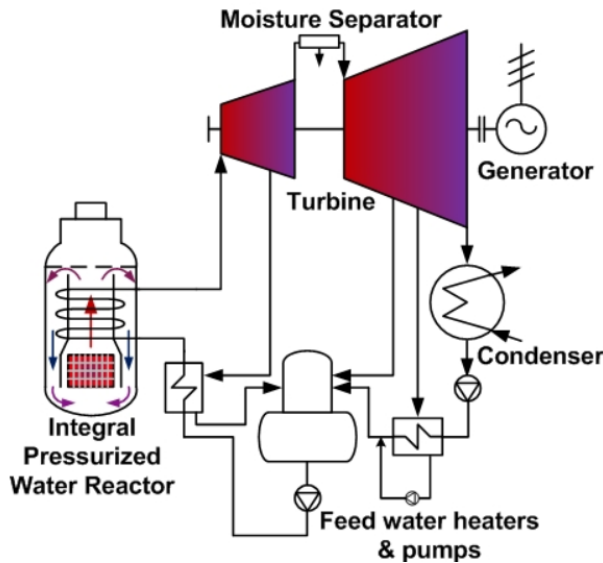

Fig. 1. Reference nuclear power plant layout with an integral small modular reactor

Each NuScale reactor could implement a small 45 MW conventional steam turbine generator set optimized to NuScale steam generator outlet conditions. As in every PWR plant case, the moisture separator and eventually re-heater have to be envisaged to prevent the erosion that may occur at the last turbines stages. The main design parameters of the NuScale single module plant are shown in Table 1.

Table 1. Design parameters of the NuScale SMR plant [17]

Reactor core thermal power	160 MW
Turbine throttle pressure	3.1 MPa
Turbine inlet temperature	255 °C
Steam flow	71.3 kg/s
Feed water temperature	149 °C
Net electric power	45 MW
Net electric efficiency	>28%

The turbine inlet temperature is not specified in publicly available NuScale information. It can be fixed from the energy balance equation of the reactor pressure vessel. As indicated in Table 1, NuScale net electric efficiency is ~28%, i.e., nearly 10% less than a typical 31-33% PWR power plant. The lower pressure predetermines this feature in the primary and secondary circuits of the plant. Large PWRs operate under the pressure of ~15 MPa and typically produce steam at ~6.0-7.0 MPa. The NuScale operating pressure at the design point is 8.27 MPa and produces steam at 3.1 MPa.

The motivation for this move is that lower operating pressures and temperatures lead to reduced stress corrosion cracking issues [18]. A similar approach is proposed in [19], [20], where some additional favourable features of the low-pressure design are revealed. Low-Pressure design leads to a considerable reduction in the pressurized component thickness (reactor vessel, steam generator, etc.), a potential increase in the fuel burn-up (less cladding corrosion), and a simplification of the safety systems. The lower primary circuit pressure design also facilitates the aforementioned integral configuration [21]. All major reactor module parameters are kept at their design values in the subsequent analyses. In this way, any changes in the NuScale design would not be needed to accommodate the addition of a super-heater that is a substantial part of the proposed Carnot battery.

2.2 Carnot Battery

It was mentioned that the Carnot Batteries operation consists of three main steps, as presented in Figure 2. Renewable or any other electricity generation when there is more supply than demand is transformed into heat during the first step A [22]. This energy conversion can be done with a heat pump based on a Brayton or Rankine cycle or with direct resistance heating. Low-temperature heat as a heat source for this step is needed if the heat pump is applied. When direct resistance heating is provided, no low-temperature heat source is needed.

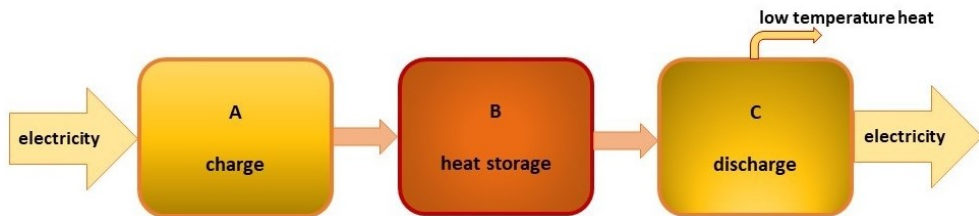

Fig. 2. The energy conversions within a Carnot Battery

The released heat is stored in thermal (heat) energy storage during the second step B. In thermal storage, use can be made of the thermal capacity of solid or liquid materials, either by their sensible (specific) heat effect (heating/cooling cycles) or by their latent heat effect at a phase change (melting/freezing cycles). The heat is converted back to electricity through Brayton or Rankine cycle during the final step C. Low-temperature waste heat is released in both cases.

As the objective is short term practical implementation of the proposed concept, only mature technologies have been considered in this study. Direct resistance heating has been selected for step A. It is by far more straightforward and cheaper than any other electricity to heat transformation process. The electrical heaters can be submerged in a tank or located in separate devices, usually named circulation heater. In both cases, Joule heating is realized. Due to this process, the passing of an electric current through a conductor releases heat with almost 100% efficiency. The most general formulas for Joule heating are [23]:

$$P = V \cdot I \quad \text{or} \quad P = I^2 \cdot R \quad W \tag{1}$$

where: P is the power converted from electrical energy to thermal energy in Watt (W); I is the current traveling through the resistor or another element in Ampere (A), V is the voltage drop across the element in Volts (V), and R is the resistance in Ohms . Industrial direct resistance heating is commercially available technology also utilized in concentrated solar power plants at the MW scale [24].

Molten salts thermal storage is proven technology suitable to be part of every Carnot battery. There is an experience with molten salts from several industrial applications related

to heat treatment, electrochemical reactions, and heat transfer. Molten salts are always attractive candidates because they have advantages in terms of high heat capacity, high density, high thermal stability, relatively low cost, and low vapour pressure. The low vapour pressure results in storage designs without pressurized vessels. The presented analysis focuses on high-temperature molten salt storage that is well established in concentrated solar power (CSP) plants [25].

The essential part of the reconversion process in this study is nuclear steam superheating with the stored thermal energy. Such of superheating can be done by using an external superheater. External nuclear superheating is not a new idea. Indian Point 1 NPP in the USA put this concept into practice back in 1962 [26]. For this purpose, an oil-fired super-heater has been used. The outlet temperature in the nuclear steam generator was 271 °C while at the turbine inlet; it was 540 °C at 2.5 MPa. 163 MW of the gross electric production was attributed to the nuclear reactor (saturated steam), with the oil-fired super-heater adding 112 MW. A net electric efficiency improvement of about 21% was estimated and achieved. Darwish et al. have proposed a similar but more efficient hybridization concept [27]. They combine the nuclear steam cycle with gas turbines. Exhaust hot gases leaving gas turbines are utilized for the superheating of the steam generated by the nuclear reactor. Popov and Borissova proposed a nuclear-solar hybrid power plant design using a sequential type integration concept [28]. In this design, nuclear heat produced by a small pressurized water reactor is used for the generation of slightly superheated steam, while solar heat is used to superheat/reheat this steam further to sub-critical conditions. The nuclear-solar hybrid plant achieves a much higher solar heat-to-electricity efficiency than the standalone CSP plant.

2.3 Integration of Carnot Battery into nuclear power plant

Several concepts for nuclear power plants with energy storage have been proposed recently. Denholm et al. envisage the integration of high-temperature thermal storage into a large nuclear power plant equipped with a prospective gas-cooled reactor [29]. The storage system is similar to those in concentrated solar plants and uses molten salts. During periods of low demand, part of the generated thermal energy is placed into storage for later use. Under this configuration, the authors expect that the reactor can work at the nearly constant output while the whole plant can cycle its power generation daily in response to the variability of the solar and wind generation.

A similar approach but implemented at a larger scale is presented in ref. [30] by Forsberg. According to it, nuclear plants operate at full capacity varying the steam flow to turbines to match electricity demand with generation (renewables and nuclear). Excess steam at times of low electricity prices or low electricity demand goes to hybrid fuel production and thermal storage systems. As this system is intended to cover seasonal mismatches between power generation and consumption, it must have huge thermal storage. The author proposes a geothermal heat storage system. It would use the nuclear reactor heat when electricity consumption is low to heat a cube of rock. This cube has to be approximately 400 m on a side, and it is put underground to create an artificial geothermal heat source.

A similar concept is developed by Green et al. [31]. The nuclear plant produces a large amount of thermal energy with the high-temperature reactor. The central part of it is used for power generation. The small portion is used for hydrogen production through high-temperature steam electrolysis. The excess nuclear heat at times of low electricity demand goes to molten salt thermal storage. Most of the employed reactors design and thermal energy storage media within the studies mentioned above are at very early stages of development. They are composed of unconventional components like molten salts cooled reactor and high-temperature thermal storage with chlorides and fluorides as a storage medium. They need significant research and development efforts.

All of the proposed concepts aim to enhance the nuclear power plant's flexibility. The role of the storage is to accumulate internally generated excess thermal energy. The idea under consideration in this paper differs significantly from the works mentioned earlier. The part of the storage herein is to store externally generated electrical energy by implementing mature technologies and components. For that purpose, the following layout of the nuclear plant with Carnot Battery is elaborated, as shown in Fig. 3.

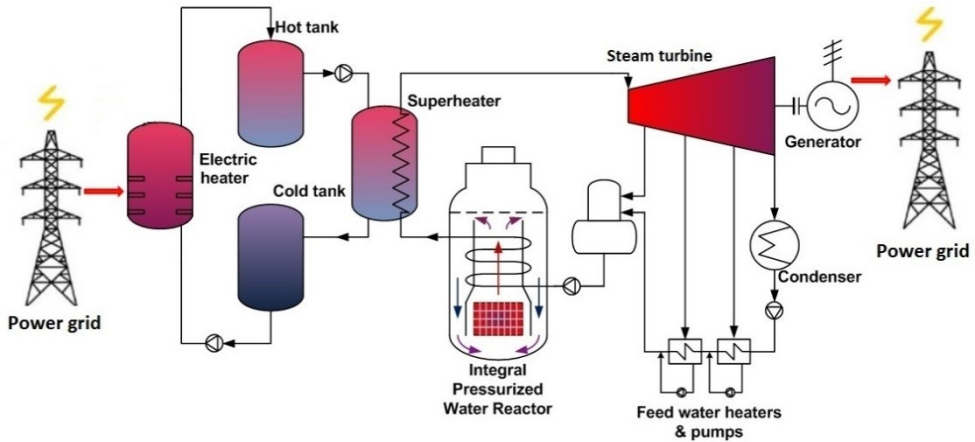

Fig. 3. The layout of a nuclear power plant with Carnot battery

The proposed configuration consists of three main sections: Carnot battery, NuScale nuclear reactor, and power block. The main role of the Carnot battery is to ensure continuous superheating of the nuclear steam while storing excess electricity from the power grid. For that purpose, it is equipped with an electric heater, two tanks thermal energy storage, superheater, and circulating pumps. The storage medium is a mixture of molten salts.

Similarly to CSP, this mixture consists of 60% sodium nitrate (NaNO_3) and 40% potassium nitrate (KNO_3). The main characteristics of the nitrate salts can be found in [32]. The freezing point of this so-called solar salt is 220°C , while the upper operating temperature is 600°C . The cold tank and the hot tank temperatures are specified in this study at 267°C and 590°C , respectively, to keep the storage medium at acceptable operating conditions. As the cold tank is connected to the super-heater outlet, the value of 267°C is also the cooled molten salt temperature. This value is well above the value of the inlet steam temperature estimated at 255°C . The outlet steam temperature is fixed at 580°C , also assuming reasonable temperature differences at the super-heater's terminal points. Similar live steam temperatures can be found in the most modern subcritical thermal power plants.

At times of low electricity demand, when there is excess power generation, cold liquid salt is pumped from the cold tank to the hot tank through molten salts electric heater. As a result, the temperature of the molten salt is increased to the design value of 590°C . Part of the heated molten salt is then directed to shell and tube heat exchangers that serve as superheater. After that, the molten salt is returned to the cold tank where it is stored and eventually reheated in the electric heater. This arrangement allows for excess heat to be stored for nuclear steam superheating outside of the period of the day with low demand. At times of high demand, the electric heater is turned off. The molten salt is conveyed only between the hot tank and cold tank leg through the super-heater.

NuScale SMR acts as the steam generator. The amount of heat produced by a nuclear reactor and its steam output flow, pressure, and temperature are kept constant at their design points. Similarly, the temperature of the feed water returning to the steam generator also

remains constant. In this way, all inlet and outlet parameters of the reactor are kept at their nominal design values, as specified in Table 1.

As described, nuclear steam is superheated with hot molten salt before entering the inlet section of the turbine. Steam exiting the high-pressure segment of the turbine could also be reheated with hot molten salts to increase its temperature before entering the next part of the turbine. Reheat makes it possible to limit or eliminate moisture at the turbine exit. Spent steam from the turbine is directed to the condenser. The turbine drives an electrical generator, which provides power to the grid. Extraction steam from the steam turbine is used to preheat the feed-water and for deaerating the feed-water. The plant may have a natural or mechanical draft cooling tower where the heat is rejected via evaporation and convection and cooled water returns to the condenser.

3 Performance evaluations

3.1 Modelling and simulation of a nuclear power plant with Carnot Battery

This section presents the simulation models used to assess the performance of the hybrid generation-storage power plant. The charging process of the Carnot battery does not need any calculation procedure as all of the heat generated by the electric heater is directly transferred into the molten salts. Thus, an electric heater is 100 % efficient [33]. It is assumed later that 1 kW electric power is converted to 1 kW of thermal power.

Concerning storage section performance, heat losses during charge, discharge, and holding have to be taken into account. Ma et al. have analysed two-tank molten salts storage losses in CSP [34]. They concluded that for large TES systems, the first-law efficiency is generally quite high — in the range of 93%-99%, with the highly effective thermal insulation applied. The first-law efficiency, in this case, is defined as the ratio of the energy extracted from the storage to the energy stored in it. Some newest version of CSP modelling SAM software estimates storage heat losses at less than 1% of the stored thermal energy [35]. It is accepted below that storage section efficiency should be 99%.

Performance evaluation of the reconversion section needs an entire nuclear power plant to be modelled. For this purpose, the modelling works in this study are carried out with Thermoflex® version 25.0, which is well-accepted and widely used software in academia and industry. Thermoflex can be used for simulation of thermal and nuclear power plants. It is a modular software with a graphical interface that allows one to assemble a model from several icons. The program covers both design and off-design simulation and models all types of power plants, including solar power plants, conventional steam cycles, and repowering [36]. The simulation at steady-state conditions is carried out using mass and energy balances applied to every component of the plants. The obtained results are the thermodynamic state of steam and water at every point of the cycle, the steam and feed-water mass flows, the power plant gross and net capacity, and electric efficiency. The output of the simulation provides also cost estimates for some major power plant components like steam turbines, heat recovery steam generators, and solar fields.

In the beginning, the reference nuclear power plant model was modelled. The simulation results are intended to be used for comparison purposes. The primary input data coincide with nuclear reactor main design parameters, as shown in Table 1. The layout of the nuclear plant with the Carnot battery model follows the description presented in paragraph 2.3. The reference nuclear power plant model was upgraded through the addition of Carnot battery components. Steam turbine inlet parameters have been adjusted for higher live steam conditions. For the sake of simplicity, steam re-heater is not envisaged. A real molten salt electric heater model is not included as such an icon is not available in the software library.

Instead, this component is represented by the equivalent heat adder icon. Thus, the needed heat, respectively, electrical capacity of the molten salt heater is calculated. A similar approach has been used by the authors in their previous work [37]. The computational schematic is shown in Figure 4.

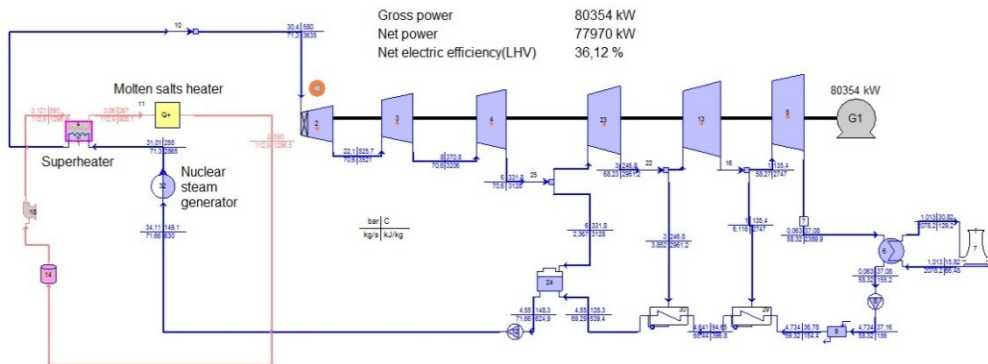

Fig. 4. Computational schematic of a nuclear plant with Carnot battery

Once the needed electric capacity per hour is calculated, the size of the heating part of the Carnot battery can be defined. The electric heater capacity has to be higher than the required hourly demand of the super-heater section. This overcapacity enables Carnot battery to be charged during the period with excess power generation in the grid. In this way, the continuous operation of the nuclear plant can be ensured, mainly when an external energy source is not available.

A similar case can be found in CSP with thermal energy storage. The size of the solar plant is defined with the so-called Solar Multiple. By definition, a Solar Multiple is the ratio of the solar field design point thermal energy output to the thermal energy demand of the power block when running at its nominal capacity [38].

A larger solar multiple implies a larger solar field. The excess energy from an oversized solar field is sent to thermal storage and subsequently delivered to the steam turbine resulting in a higher plant capacity factor. A parameter with similar meaning can be named Storage Multiple in the current context. An electric heater with a Storage Multiple of 2 can enable nuclear steam superheating 24 h a day, including 12 h when an external energy source is not available. It also means that the charging period of the Carnot Battery will be 12 h. It has to coincide with the time of over-generation in the grid.

The periods with such long-lasting over-generation can be found in the grids with high penetration of renewable energy and especially with massive PV electricity generation. In earlier 2013, the California Independent System Operator (CAISO) announced the so-called “duck curve,” a chart showing a significant drop in mid-day net demand on a spring day as solar photovoltaic generation is added to the system [39], Figure 5. It is based on CAISO's real-time analysis and forecast of electricity net demand from 2012 to 2020. The net demand load represents the number of conventional generation plants (excluding renewables) that will need to be on-line during different times of the day.

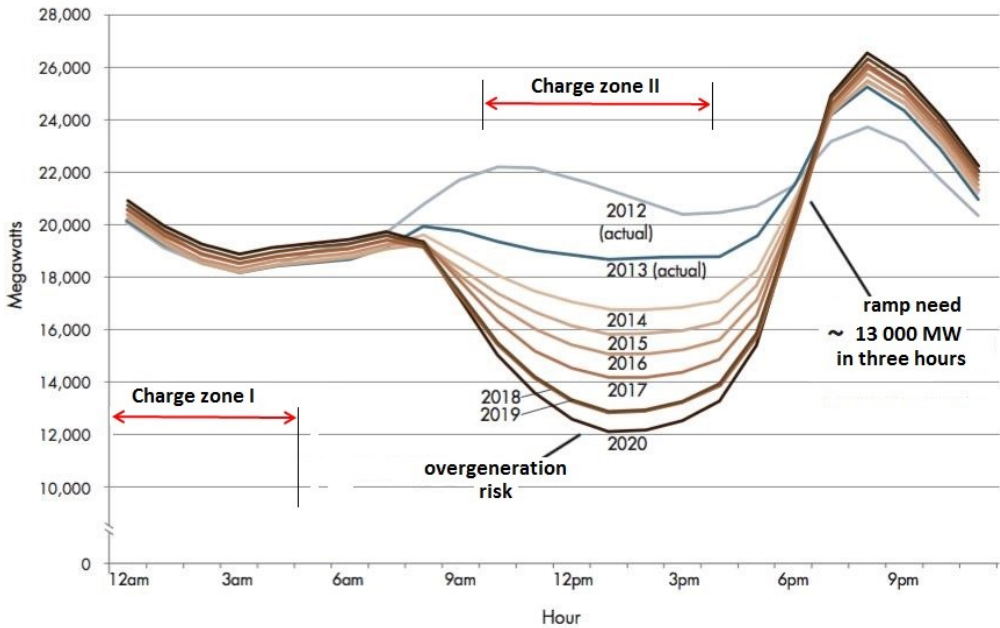

Fig. 5. Duck curve of California from 2012 (actual) to 2020 (predicted): adopted from [39]

The chart raises anxiety that the conventional power system will be unable to perform the ramp rate and range needed to utilize renewable energy fully. As a result, the grid operator might be forced to curtail this type of generation to keep the system stability. Andrews has reported that similar problems can also be observed in other countries with a high level of renewable energy penetration like Germany, France, and Australia [40].

Denholm et al. analysed the duck chart in detail, investigating how much photovoltaic generation might need to be cut down if additional grid flexibility measures are not added, and how curtailment rates can be reduced by changing the grid operational practices [41]. They found that under business-as-usual scenarios and corresponding levels of grid flexibility in California, solar diffusion as low as 20% of annual power generation could lead to marginal curtailment rates that exceed 30%.

The duck chart also reveals that power grids dominated by renewable energy sources will have two zones with low demand daily. The first one, roughly from 12 a.m. till 5 a.m. or night zone, is well known and typical for every power grid before the renewable era. The second zone from 10 a.m. till 5 p.m. is a new one. Excessive solar electricity generation shapes it. Both zones, resp. Charge zone I and Charge zone II at Fig. 5, with a total duration of 12 hours are suitable for charging of energy storage as the Carnot battery in the current case.

Thermal storage capacity is usually estimated in MWh according to the stored thermal energy. In molten salt energy storage, this parameter is very often defined in hours. The thermal energy storage system capacity in hours is the number of hours that the TES can drive the power cycle at its rated capacity. Ju et al. have reviewed several photovoltaic/concentrated solar power (PV-CSP) hybrid systems located in Sought Africa and Chile with 12, 14, 15, and 17.5 h molten salt TES [42]. In the present case with Storage Multiple of 2, the potential storage capacity could be 12 h. It means that the Carnot battery can ensure continuous nuclear steam superheating at the plant's design point for almost 24 h. In this way, the hybrid generation-storage plant can be operated in base-load mode 24 hours

a day. The proportion between Storage Multiple and TES capacity might vary concerning the local grid economic and technical conditions and limitations.

3.2 Figures of performance

In thermodynamics, the energy conversion efficiency (η) is a dimensionless performance measure of a device or system that uses thermal energy. The first law measure of efficiency is the ratio of useful output energy to input energy. Accordingly, the efficiency of the reference NPP is calculated as the ratio of the net produced power by the generator driven by the steam turbine and the thermal energy supplied by the nuclear fusion in RPV:

$$\eta_{NPP} = \frac{P_{NPP}}{Q_{RPV}} \quad (2)$$

where P_{NPP} is net produced power by the reference nuclear power plant, Q_{RPV} is thermal energy produced by the reactor.

For the nuclear plant with Carnot battery, the power block efficiency can be calculated similarly, but taking into account also the external heat contribution:

$$\eta_{NPCB} = \frac{P_{NPCB}}{Q_{RPV} + Q_{th\ superh}} \quad (3)$$

where P_{NPCB} is net produced power by the nuclear power plant with Carnot battery; $Q_{th\ superh}$ is the thermal power input in the super-heater. This parameter can be calculated from the change in enthalpy in the molten salt Δh_{superh} :

$$Q_{th\ superh} = m \cdot \Delta h_{superh} \quad (4)$$

where m is the mass flow of the molten salt through the super-heater.

$Q_{th\ superh}$ can also be estimated as thermal power extracted from molten salt TES.

From the storage efficiency defined as the ratio of the energy extracted from the storage to the energy stored in it one can calculate the power put per hour in the Carnot Battery P_{in} :

$$P_{in} = Q_{th\ superh} / \eta_{TES} \quad (5)$$

The estimated storage efficiency η_{TES} is set at 0.99.

It is expected that the nuclear plant with Carnot battery can generate more power, due to additional heat input and more efficient thermodynamic cycle as a result of the steam superheating. The difference between the hybrid configuration net electric power and reference NPP net electric power gives net incremental power generation:

$$P_{inc} = P_{NPCB} - P_{NPP} \quad (6)$$

where P_{inc} is the incremental power production that could be attributed to external heat.

4 Results

4.1 Results from power plants simulation

The performance of the analysed power plants is evaluated with the simulation models described in the previous section. The main output parameters from simulations are shown in Table 2 and Fig. 4. The steam turbine assembly total estimated installed cost is also presented. Reference Nuclear plant is compared with the nuclear plant with Carnot battery.

All inlet and outlet parameters of the nuclear reactor are the same in both cases. The main difference is in the turbine inlet temperature. It is higher in the second configuration due to the addition of excess heat in an external super-heater. The substantial increase of turbine inlet temperature eliminates steam moisture in all turbine stages of the hybrid plant. As a result, the steam turbine isentropic efficiencies are considerably higher in this case.

Due to extra heat and more favourable thermodynamic conditions, the nuclear plant with Carnot battery generates much more electric power than the reference NPP. Incremental power produced by the combined plant is only 25% less than the capacity of the standalone NPP. Due to the higher turbine inlet temperature, the combined configuration is more efficient than ordinary NPP. The results show that its net electric efficiency exceeds 36%, thus approaching the effectiveness of the current fleet of thermal power plants.

As mentioned earlier, Thermoflex software applies a method of estimating steam turbine size, weight, and cost. The larger steam turbine usually benefits from the economy of scale. In the reference case, the total estimated cost of steam turbine assembly is about 14 million USD. The cost of steam turbine assembly within the nuclear plant with Carnot battery is 21.94 million USD or almost 8 million more. Therefore, the proposed combination of a power plant and energy storage leads to a slightly lower power block installed cost per kilowatt: 280 USD/kW instead of 312 USD/kW.

Table 2. Comparison between references NPP and nuclear plant with Carnot battery

Parameters/ Plant configuration	Reference NPP	NPP with Carnot Battery
<i>Power block parameters</i>		
Live steam flow, (kg/s)	71.30	71.30
Turbine inlet temperature, (°C)	255	580
Turbine inlet pressure, (MPa)	3.1	3.040
Condenser pressure, (MPa)	0.0063	0.0063
Exit steam quality x (%)	80.6	99.8
Feed water temperature, (°C)	149	149.1
<i>Steam turbine isentropic efficiencies</i>		
Steam turbine group 1 efficiency, %	88.76	88.86
Steam turbine group 2 efficiency, %	88.07	91.45
Steam turbine group 3 efficiency, %	84.99	92.47
Steam turbine group 23 efficiency, %	83.07	93.25
Steam turbine group 13 efficiency, %	80.83	94.52
Steam turbine group 5 efficiency, %	80.12	94.12
<i>Plants summary</i>		
Nuclear heat input, (kW)	159 975	159 975
Thermal input in the superheater, (KW)	n.a.	55 870
Total heat input, (kW)	159 975	215 845
Gross electric Power, (kW)	48 457	80 354
Net electric Power, (kW)	45 005	77 970
Incremental Electric Power, (kW)	n.a.	32 965
Net electric efficiency, (%)	28.14	36.12
Net heat rate, (kJ/kWh)	12 795	9344
Steam turbine total estimated installed cost, USD	14 057 000	21 940 00

4.2 Storage efficiency and costs

The proposed nuclear plant with a Carnot battery can provide grid-scale storage of electricity. One of the vital storage system characteristics is its round-trip efficiency. As mentioned, this parameter is usually defined as the ratio of the energy extracted from the storage to the energy stored in it. The round-trip efficiency on an hourly basis can also be expressed as a ratio of power produced by the storage system to the power put in it. Therefore, the ratio between incremental power generation and power put in the storage represents the round-trip efficiency η_{CB} of the Carnot Battery under consideration:

$$\eta_{CB} = \frac{P_{inc}}{P_{in}} \cdot 100 \% \quad (7)$$

The thermal power input in the super-heater, as determined by the previous analysis, is 55 870 kW. The power put in the Carnot battery can be calculated with equation 5:

$$P_{in} = Q_{th\ superh} / \eta_{TES} = 55\ 870 / 0,99 = 56\ 434,3\ kW \quad (8)$$

Therefore, the round-trip efficiency of the Carnot Battery is:

$$\eta_{CB} = \frac{P_{inc}}{P_{in}} = \frac{32\ 965}{56\ 434,1} \cdot 100 = 58,4\% \quad (9)$$

The obtained result is rather promising. According to it, in terms of efficiency, the proposed storage technology is more efficient than the compressed air storage and could be positioned close to pumped hydro energy storage, but without any geographical restrictions.

The capital cost of thermal storage depends on its capacity. As mentioned, thermal storage capacity is usually estimated in MWh, respectively, in kWh according to the stored thermal energy. The power put in the Carnot battery has been calculated 56 434.3 kW. For 12 h storage, as selected in this study, the stored heat is reckoned at 677 212 kWh. The employed storage technology is very similar to that in Molten Salt Power Tower plants. The specific capital cost of the current 2-tank sensible heat molten salts TES technology employed in this type of solar power plants is currently estimated at 22 USD per kWh [35]. Accordingly, the thermal storage cost can be calculated at almost 15 000 000 USD.

Attributable to this system, 32 965 kW of electricity is generated. This surplus generation is done with the more powerful and expensive steam turbine than this one in the reference nuclear power plant. As calculated in the previous subsection, this extra capacity costs 8 million USD. Therefore, the total installed cost of the presented Carnot battery amounts to 23 million USD or almost 700 USD per kW.

A brief comparison with the competing storage technologies is presented in Table 3. The total installed costs in USD per kW generated by the storage are analyzed. Carnot battery output capacity is approximated to 33 000 kW. All storage plants have the same output capacity.

Table 3. Comparison of major storage technologies with Carnot Battery integrated into NPP

Energy storage technology/costs	Specific installed costs, USD/kW	Storage output, kW	Total installed storage costs, USD
Pumped hydro	2 230	33 000	73 590 000
Compressed air	900	33 000	29 700 000
Lithium-ion battery	2 500	33 000	82 500 000
Nuclear plant with Carnot Battery	700	33 000	23 100 000

Specific installed costs data for Pumped hydro and Compressed air energy storage plants are taken from a reliable source with a strong engineering background [43]. The actual date for Lithium-ion battery installed costs can be found in [44] and [45]. Particularly in [50], for

large-scale battery storage with long-duration, a median value of 2 500 USD/kW is suggested. The proposed Carnot battery integrated into NPP represents the least expensive technology. The next in terms of installed cost is Compressed air energy storage, but this technology imposes geographical and environmental limitations at lower round-trip efficiency.

4.3 Conclusions

This paper presents a concept for the integration of a Carnot battery into a small nuclear power plant. The concept relies on the assumption that excess electricity from the grid is firstly converted into heat that afterwards is used for nuclear steam superheating. As soon as nuclear steam is superheated, it can generate more power. The plant is equipped with molten salt thermal energy storage for continuous superheating to be ensured.

The simulations of the reference nuclear power plant and nuclear power plant with Carnot battery and their analysis provide the following research findings. The efficiency of the combined generation-storage nuclear plant can be considerably increased up to the effectiveness level of the modern thermal power plants. The integrated thermal storage acts as secondary and ample electricity storage. As such, it surpasses compressed air storage and is competitive with the pumped hydro storage regarding round trip efficiency and installed costs, in the absence of their geographical and environmental constraints. Regardless of falling prices and sunk costs, Lithium-ion Energy storage technology is still costly and cannot rival with the presented combination of small NPP and Carnot battery. The proposed concept makes the co-location of NPP and Carnot Battery more attractive than the separate plants.

All components of the combined generation-storage plant, except the nuclear reactor that is at the demonstration stage, are commercially available. However, there are similar SMR at a more advanced stage of deployment. For these reasons, the proposed combined plant can be readily assembled with proven elements. Further increase of round-trip efficiency could be achieved with advanced high-temperature (400-800 °C) thermal energy storage that is under development for next-generation concentrated solar power plants.

References

1. A. Prag., The IEA Sustainable Development Scenario. Katowice, (6 December 2018);
2. IRENA, Renewable capacity highlights 31 March 2019. https://www.irena.org/-/media/Files/IRENA/Agency/Publication/2019/Mar/RE_capacity_highlights_2019.pdf?la=en&hash=BA9D38354390B001DC0CC9BE03EEE559C280013F&hash=BA9D38354390B001DC0CC9BE03EEE559C280013F
3. D. O. Akinyele, R.K. Rayudu. Review of energy storage technologies for sustainable power networks. *Sustainable Energy Technologies and Assessments* **8** (2014) 74–91.
4. M. Finkenrath, S Pazzi, M. D’Ercole, R. Marquardt, P. Moser, M. Klafki, S. Zunft. Status and Technical Challenges of Advanced Compressed Air Energy Storage (CAES) Technology. (2009) *International Workshop on Environment and Alternative Energy*.
5. IEA: Tracking clean energy progress 2017: Energy technology perspectives (2017) (2017). Available at: <https://www.iea.org/publications/freepublications/publication/TrackingCleanEnergyProgress2017.pdf>
6. P. Hutchins, U.S. utility-scale battery storage power capacity to grow substantially by 2023. July 10, (2019). <https://www.eia.gov/todayinenergy/detail.php?id=40072>

7. J. F. Parker, C. N. Chervin, I. R. Pala, M. Machler, M. F. Burz, J. W. Long, D. R. Rolison. Rechargeable nickel–3D zinc batteries: An energy-dense, safer alternative to lithium-ion Science (28 Apr 2017): Vol. **356**, Issue 6336, pp. 415-418
8. L. Kong, Chuan Li, Jiuchun Jiang and Michael G. Pecht. Li-Ion Battery Fire Hazards and Safety Strategies. *Energies* (2018), 11(9), 2191;
9. M. Geyer, S. Freund. *Webinar on Carnot Batteries*. (2019) https://atainsights.com/wp-content/uploads/2019/04/190404-_Michael-Geyer-Sebastian-Freund-Webinar-Carnot-Batteries-distr.pdf
10. D. Stevanovic, High Temperature Energy Storage (HiTES) with Pebble Heater Technology and Gas Turbine. In *Book Advancements in Energy Storage Technologies*. (May 2018). <http://dx.doi.org/10.5772/intechopen.75093>
11. L. Meroueh, G. Chen. Thermal energy storage radiatively coupled to a supercritical Rankine cycle for electric grid support. *Renewable Energy*. Volume **145**, (January 2020), Pages 604-621
12. A. Thess, Thermodynamic Efficiency of Pumped Heat Electricity Storage. *PHYSICAL REVIEW LETTERS*. American Physical Society. (September 2013).
13. R. B. Laughlin, Pumped thermal grid storage with heat exchange. *Journal of Renewable and Sustainable Energy* **9**, 044103 (2017);
14. I. N. Kessides, The future of the nuclear industry reconsidered: Risks, uncertainties, and continued promise. *Energy Policy*, **48** (2012), pp. 185-208;
15. J. Vujic, R. M. Bergmann, R. Skoda, M. Miletic. Small modular reactors: Simpler, safer, cheaper? *Energy*, Volume **45**, Issue 1, (September 2012), Pages 288–295.
16. Z. Liu, J. Fan. Technology readiness assessment of Small Modular Reactor (SMR) designs. *Progress in Nuclear Energy*, **70** (2014), pp. 20-28.
17. C. Colbert, Overview of NuScale Design. Technical Meeting on Technology Assessment of SMRs for Near-Term Deployment Chengdu, China, (September 2-4, 2013).
18. J. N. Reyes, Introduction to NuScale Design. NuScale Power Inc. July 24, (2008). U.S. Nuclear Regulatory Commission.
19. S. Nisan, P. Raymond, G-M. Gautier, J-F. Pignate. Requirements and specifications for a simplified, low pressure medium sized PWR. *Proceedings of the International Conference: Nuclear option in countries with small and medium electricity grid*. http://www.iaea.org/inis/collection/NCLCollectionStore/_Public/29/064/29064452.pdf Last accessed: March, 2017
20. D. Popov, B. Neykov . I Innovative PWR plant design concept with low primary circuit pressure. *International Conference on Innovative Technologies for Nuclear Fuel Cycles and Nuclear Power*, (23-26 June 2003) Vienna, Austria. http://www.iaea.org/inis/collection/NCLCollectionStore/_Public/34/068/34068009.pdf
21. G. M. Gautier, M. S. Chenaud, B Tourmiaire. SCOR 1000: An economic and innovative conceptual design PWR. *Proceedings of ICAPP '07 Nice*, FRANCE, (May 13-18, 2007), Paper 7417. <http://www-ist.cea.fr/publiccea/exl-doc/200600007017.pdf> Last accessed: March, 2017
22. Carnot Batteries. International Energy Agency. DLR. https://www.dlr.de/tt/Portaldata/41/Resources/dokumente/tp/Carnot_Batteries_backgrund_document-V2.pdf
23. Alexandra von Meier, *Electric Power Systems: A Conceptual Introduction*. July 2006 Wiley-IEEE Press.
24. Chromalox. Precision Heat and Control Systems For Solar Power Energy Production. <https://www.chromalox.com/-/media/files/literature-old/lit-px121.pdf?la=en>

25. R. L. Dunn, P. J. Hearps, M. N. Wright. Molten-Salt Power Towers: Newly Commercial Concentrating Solar Storage. *Proceedings of the IEEE | Vol. 100, No. 2, (February 2012)*. <https://DOI:10.1109/JPROC.2011.2163739>
26. D. J. McCormick and W. P. Gorzegno, The separately fired super-heater - a nuclear application at Indian Point. ASME Paper 65-PWR-14, *ASME-IEEE National Power Conference, Albany, New York, (Sept. 19-22, 1965)*;
27. M.A. Darwish, Fatimah M. Al Awadhi, Anwar O. Bin Amer. Combining the nuclear power plant steam cycle with gas turbines. *Energy, Volume 35, Issue 12, (December 2010), Pages 4562–4571*
28. D. Popov, A. Borissova. Innovative configuration of a hybrid nuclear-solar tower power plant. *Energy. Volume 125, (15 April 2017), Pages 736-746.*
29. P. Denholm, J. C. King, C. F. Kutcher, P. H. Wilson. Decarbonizing the electric sector: Combining renewable and nuclear energy using thermal storage. *Energy Policy, Volume 44, (May 2012), Pages 301-311.*
30. C. Forsberg. Hybrid systems to address seasonal mismatches between electricity production and demand in nuclear renewable electrical grids. *Energy Policy. Volume 62, (November 2013), Pages 333-341 ;*
31. M. Green, P. Sabharwall, M. Mckellar, Su-Jong Yoon, C. Abel, B. Petrovic, D. Curtis, "Nuclear Hybrid Energy System: Molten Salt Energy Storage," Report INL/EXT-13-31768, Idaho National Laboratory (November 2013);
32. D. Kearney, B. Kelly, R. Cable, N. Potrovitza. Overview on use of a Molten Salt HTF in a Trough Solar Field. NREL Parabolic Trough Thermal Energy Storage Workshop Golden, CO, (February 20-21, 2003);
33. "Electric Resistance Heating - Department of Energy". *Energy.gov*. <https://www.energy.gov/energysaver/home-heating-systems/electric-resistance-heating>
34. Z. Ma, G. C. Glatzmaier, M. Wagner, T. Neises. General Performance Metrics and Applications to Evaluate Various Thermal Energy Storage Technologies. *Proceedings of the ASME 2012 6th International Conference on Energy Sustainability, ES2012, (July 23-26, 2012), San Diego, CA, USA;*
35. C. S. Turchi, M. Boyd, D. Kesseli, P. Kurup, M. Mehos, T. Neises, P. Sharan, M. Wagner, T. Wendelin. (2019). CSP Systems Analysis - Final Project Report. Golden, CO, USA: National Renewable Energy Laboratory. NREL/TP-5500-72856, May 2019.
36. P. Griffin, K. Huschka, G. Morin, G., (2009). Software for design, simulation and cost estimation of solar thermal power and heat cycles. *Proceedings of the SolarPACES 2009 Conference in Berlin, Germany.*
37. A. Borissova, D. Popov. An option for the integration of solar photovoltaics into small nuclear power plant with thermal energy storage. *Sustainable Energy Technologies and Assessments. Volume 18, (December 2016), Pages 119-126*
38. J. Jorgenson, P. Denholm, M Mehos, C Turchi. Estimating the performance and economic value of multiple concentrating solar power technologies in a production cost model. Technical Report NREL/TP-6A20-58645, (December 2013).
39. Demand response and energy efficiency roadmap: maximizing preferred resources. Folsom, California: California Independent System Operator; (2013) <https://www.caiso.com/documents/dr-eeroadmap.pdf>
40. R. Andrews. The California Duck Curve isn't confined to California. *Energy Matters. (November 15, 2017).*
41. P. Denholm, M. O'Connell, G. Brinkman, J. Jorgenson. Overgeneration from Solar Energy in California: A Field Guide to the Duck Chart. Technical Report NREL/TP-6A20-65023. (November 2015).

42. X. Ju, C. Xu, Y.Q. Hu, X. Han, G.S. Wei, X.Z. Du. A review on the development of photovoltaic/concentrated solar power (PV-CSP) hybrid systems. *Solar Energy Materials and Solar Cells* Volume **161**, (March 2017), Pages 305-327.
43. Cost and Performance Data for Power Generation Technologies. Cost report Prepared for the National Renewable Energy Laboratory. Black & Veatch Corporation (2012). <https://www.bv.com/docs/reports-studies/nrel-cost-report.pdf>
44. R. Fu, T. Remo, R. Margolis. (2018) U.S. Utility-Scale Photovoltaics Plus-Energy Storage System Costs Benchmark. Golden, CO: National Renewable Energy Laboratory. NREL/TP-6A20-71714.
45. U.S. Battery Storage Market Trends. U.S. Energy Information Administration. (May 2018) https://www.eia.gov/analysis/studies/electricity/batterystorage/pdf/battery_storage.pdf