

# Improved Method of Calculation The Electromagnetic Generator For Environmentally Friendly Method of Forming Coolant

*Andrii Bereziuk*<sup>1,\*</sup>, *Olexiy Karlov*<sup>2</sup>, *Kryshchuk Roman*<sup>2</sup>, *Anatoliy Mrachkovsky*<sup>1</sup>, and *Vitaliy Nalyvaiko*<sup>1</sup>

<sup>1</sup>The National University of Life and Environmental Sciences of Ukraine, Kyiv, Ukraine

<sup>2</sup>The Institute of Electrodynamics of the National Academy of Sciences of Ukraine, Kyiv, Ukraine

**Abstract.** A comparative analysis of the results of numerical modelling of electrophysical processes occurring in the middle of a cylindrical inductor with loading in the form of a beam of ferromagnetic pipes, using various tube plates on the ends of the loading, which is a component of the ecologically clean technology of processing biomass into fuel, is carried out. According to the results of computer simulation, it was found that the construction of "snowflakes" in comparison with round ferromagnetic boards allows reducing losses in them, increasing the capacity of the induction heater, and also passing the coolant, both from the inside of the pipes and from the outside.

## 1 Introduction

In the technological processes of biomass processing of vegetable origin, it is often necessary to heat it in the technologies of the production of granular fuels. Heat treatment can also be used in the preparation of sowing material, cooking of various fodder, drying of agricultural products, etc.

For traditional methods of temperature treatment of materials of vegetable origin mainly devices, in which the generation of heat is carried out by burning various types of mineral or organic fuel, accompanied by harmful emissions into the environment and pollution of the atmosphere.

One of the promising and safe methods of heating a heat-exchange device is the induction mode of energy transfer [1], which is based on the event under an alternating electromagnetic field vortex currents in the electroconductive medium (which is based on eddy currents in the electroconductive material.). At the same time, due to the flow of eddy currents, the heating of the metal elements of the heater (heat exchanger) is carried out in accordance with the law of Joule, followed by the transfer of heat (convection and radiation) to the coolant.

Note that induction heating has several advantages:

- High density of electromagnetic energy flow;

---

\* Corresponding author: [marshall241987@gmail.com](mailto:marshall241987@gmail.com)

- Ability to achieve the required temperatures in the heated body (in a fairly wide range);
- The heating process is environmentally friendly;
- Ability to control the temperature distribution by constructive solutions, changing the operating modes of the induction equipment (frequency, supply voltage);
- Relatively high-energy performance (efficiency,  $\cos\varphi$ ).

To analyse the energy performance of induction heaters of various purpose should be carried out mathematical modelling of electromagnetic fields. In analysing the electromagnetic field in a ferromagnetic medium with a nonlinear magnetic permeability, the most widely used today are analytical and numerical methods of calculation, and also physical modelling.

The well-known analytical methods [2-4] are based on the solution of differential equations, which are based on the equations of the electromagnetic field, and widely use the theory of electric and magnetic circles, as well as the theory of electromagnetic fields.

The analytical method of calculating induction systems proposed in [2, 4] does not allow for the consideration of the presence of pipe boards made of ferromagnetic or electrically conductive material at the loading ends, which induces the use of boards from dielectric materials.

## 2 Materials and Methods

The electromagnetic field in this case (for instance in cylindrical inductor) can be calculated on the basis of Maxwell's equations system.

$$\operatorname{rot}\mathbf{H} = \mathbf{j}, \quad \operatorname{rot}\mathbf{E} = -j\omega\sigma\mathbf{B}, \quad \operatorname{div}\mathbf{B} = 0 \quad (1)$$

and the constitutive relations:

$$\mathbf{B} = \mu\mathbf{H}, \quad \mathbf{j} = \sigma\mathbf{E} \quad (2)$$

where  $\mathbf{B}$ ,  $\mathbf{H}$ ,  $\mathbf{E}$ ,  $\mathbf{j}$  - the vectors of a magnetic induction, the intensity of magnetic and electric field, current density;

$\sigma$ ,  $\mu$  - the electrical specific conductivity and the magnetic permeability of tube material, which are taken as a constant for this problem. In the external area conductivity is equal to zero and magnetic permeability is equal to vacuum permeability  $-\mu_0$ .

This causes many problems, both with the manufacture of these boards, and their attachment to the metal loading elements (pipes). The most technologically advanced are steel pipe boards, but unfortunately it is impossible to take into account their influence on the parameters of induction systems calculated by the analytical method [2, 4]. Therefore, to solve such problem, we can use the finite element method [5-9] in a three-dimensional formulation, and then carry out experimental research.

Purpose of work. Improvement of the calculation method of the electromagnetic system of heat generators for environmentally friendly methods of forming the heat carrier by taking into account in the mathematical model of the final effect in the zones of pipe plates and clarifying the energy balance of the induction system.

Let's analyse the distribution of power losses in different loading elements of cylindrical inductor with different execution of pipe boards. In fig. 1 shows a calculation model of the cylindrical inductor with different types of pipe boards. As the load will be used three water pipes 1/2 (d15xD21,3 mm) length 300 mm ( $\sigma_C = 7,7 \cdot 10^6 \text{ Sm/m}$ ,  $\mu = 50 \mu_0$ ). The pipes are placed at the distance of 15 mm from the axis of the inductor and displaced from each other at the angle of 120°. Pipe boards with a diameter of 60 mm and a thickness of 5 mm have the same electrophysical parameters as pipes.

The inductor is presented in the form of a cylinder with the dimensions, which are presented in Fig. 1a, is made of 48 turns of copper wire ( $\sigma_m = 48,5 \cdot 10^6 \text{ Sm/m}$ ). A winding current is supplied with amplitude 530 A and a frequency of 50 Hz. Since the induction heater is symmetric in length, for simulation we will use only its half (Fig. 1d), and at the cut-off boundary we will use the condition of symmetry.

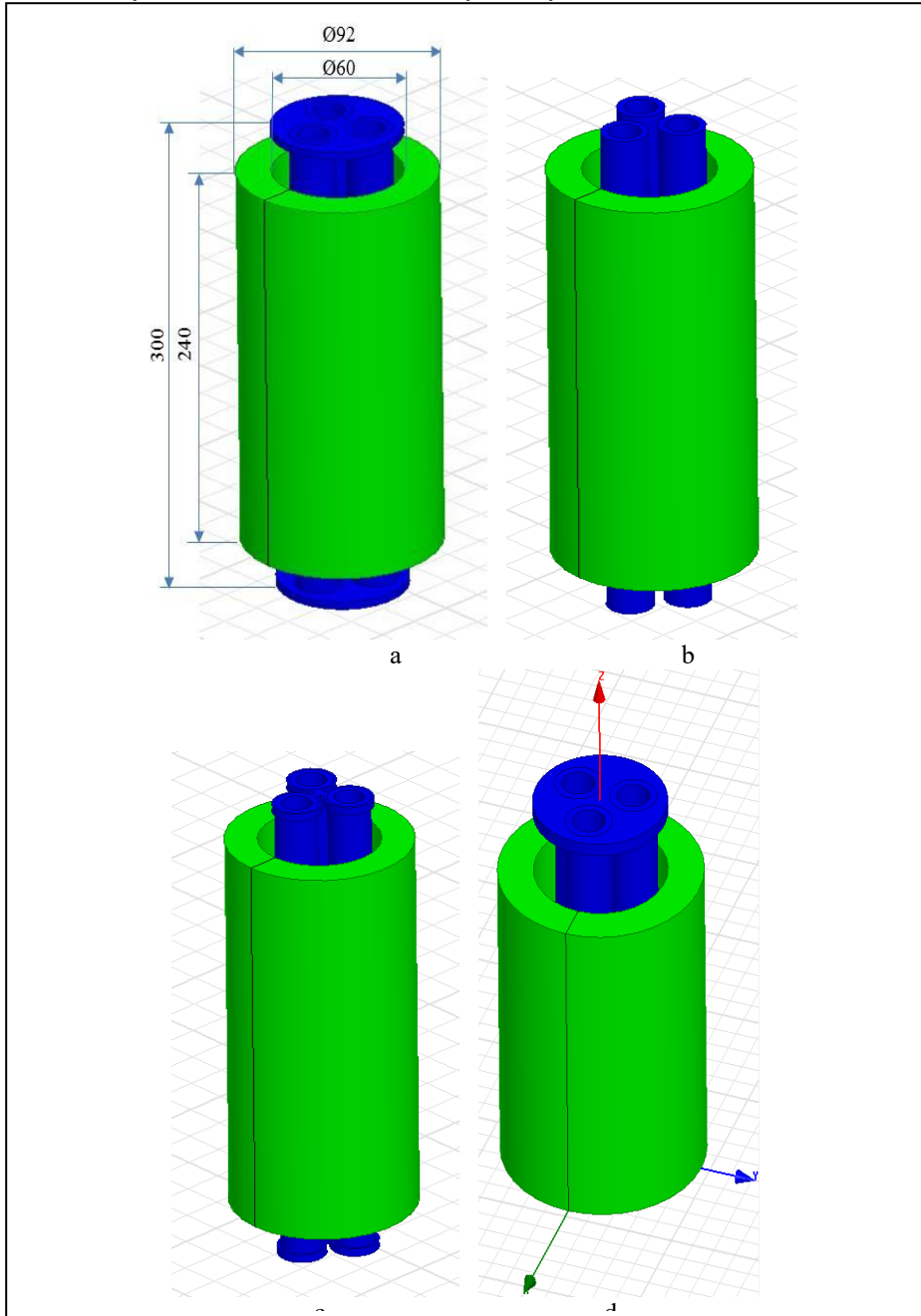

**Fig. 1.** Cylindrical inductor with different types of pipe boards

For comparison, we use an induction heater in which the pipe boards are made of ferromagnetic ( $\sigma_c = 0$  Sm/m) and charged ( $\sigma_c = 7,7 \cdot 10^6$  Sm/m) steel (Fig. 1a), with boards of dielectric material (fig. 1b), and boards made of ferromagnetic steel in the form of "snowflake" with a thickness of brattice 4 mm (Fig. 1c). Pipe boards presented in Fig. 1c are proposed because they can be manufactured technologically and cheaply using a laser CNC cutter, and for greater rigidity, the outside is secured by a dielectric ring.

### 3 Materials and research methods

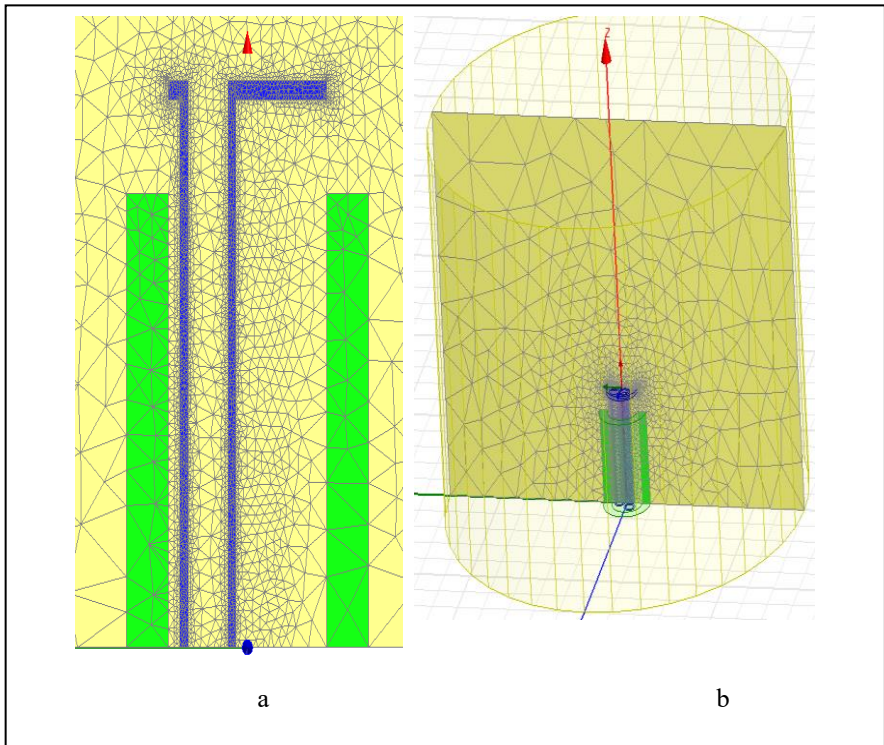

**Fig. 2.** The number of finite elements.

ANSYS Electromagnetics Suite software was used for simulation in a three-dimensional formulation using finite element method. The induction heater is in the air sphere of a cylindrical shape with a diameter of 700 mm and a height of 1000/2 mm, on the outer surface of which the condition of the ideal magnetic circuit was taken. This condition is adopted in order to reduce the size of the air area, because when applying the condition of isolation at its boundaries ( $A=0$ ) the air gap should be increased by 2-3 times. At other boundaries between media accepted term continuity.

In Fig. 3 shows the distribution of losses in the loading elements, from which shows that the main losses along the length of the pipe are concentrated in the central zone, and in depth – on the outer surface of the pipes. In this way, the coolant is expedient to pass outside the pipes, but not inside. In addition, the losses in the pipe board are concentrated near the pipes and locked between them, as seen from Fig. 3. In this case, such loading geometry does not significantly affect the losses in the pipe boards, but with the increase in

the number of pipes in the load, respectively, and increase power losses in the boards, which can lead to damage to the induction system.

The energy characteristics of induction systems with different execution of pipe boards are presented in Table 1, where I is the operating current, U - operating voltage module, P - losses in loading, P<sub>p</sub> - losses in one whole pipe, P<sub>b</sub> - losses in the pipe board, P<sub>w</sub> - losses in the winding, S - full power.

From the table 1 loss in the pipe board for the type at Fig. 1c of its implementation is much smaller than in the round execution (Fig. 1a), that indicates the justification for using such technical solution.

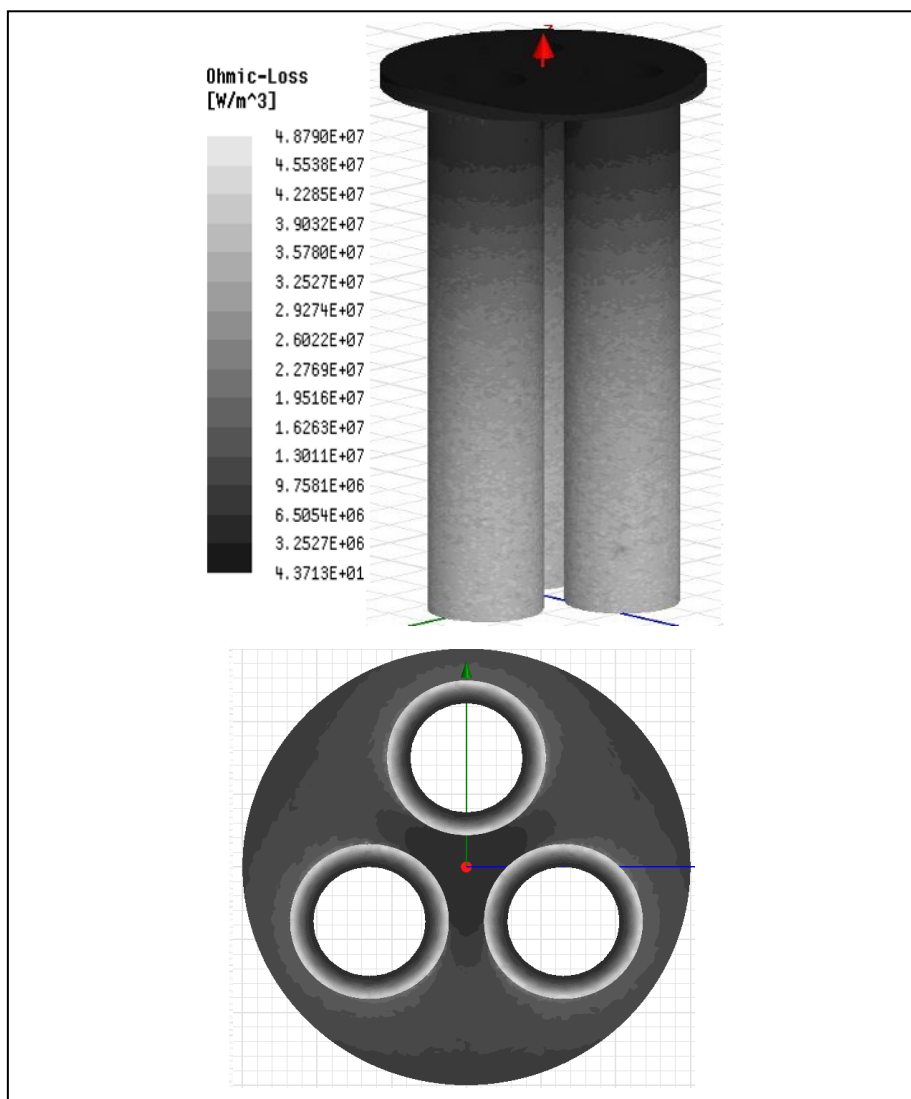

**Fig. 3.** The distribution of losses in the loading elements.

**Table 1** Loss in the pipe boards

Value	Round Solid Ferromagnetic Pipe Board	Round Charged Ferromagnetic Pipe Board	Round Dielectric Pipe Board	Ferromagnetic Pipe Board as "Snowflake"
I, A	347,7	347,7	347,7	347,7
U, V	23,06	23,17	22,62	22,7
P, W	2008,8	1956	1841,7	1861
P <sub>p</sub> , W	649,9	652	613,9	619
P <sub>b</sub> , W	29,6	0	-	2,1
P <sub>w</sub> , W	415,7	416	415,42	415,9
S, VA	8748,46	8787,63	8575,66	8609
cos(φ)	0,277	0,27	0,2632	0,2645

At the same time, an induction heater with laminated pipe board to be quite profitable, thanks which somewhat increases the power of the induction device.

Reduce the impact of pipe boards on energy performance inductor possible using fairly long and thin induction heaters, but it has several drawbacks and, in some cases, the inability to use them. Multi-tube induction heaters must be explored in three-dimensional formulation using the finite element method, because need to take into account the effect from pipe boards. Effect from pipe boards can significantly improve or worsen the characteristics of the device and it is quite difficult to calculate by analytical methods.

For example, consider comparison with a round pipe board variant and in the form of a «snowflake» board with 36 ones of pipes for both variants. The losses in a round board (Fig. 1a) amounted to 573 W, while in the form of a «snowflake» - 22 W, with the average loss in one pipe - 230 W. The power losses in the inductor with the round pipe board are 22% larger than the load of a «snowflake» pipe board.

## 4 Conclusions

According to the results of computer simulation, it was found that the design of pipe boards in form of "snowflake" in comparison with round ferromagnetic boards allows to reduce losses in them more than 10 times, and also to better passage the coolant from the inside of the pipes and from the outside better.

In addition, the application of round ferromagnetic pipe boards from the laminated steel at the same geometric sizes allows us to increase the power of the induction heater.

## References

1. V.Nemkov, V. Demidovich, Energoatomizdat, p. 280, (1988).
2. I. Kondratenko, A. Bereziuk, A. Raschepkin, Bulletin of the Kremenchug DPU, Ukraine, issue **3 (62)**, vol. **2**, pp. 56-60 (2010).
3. T. A. Jankowski, N. H. Pawley, L. M. Gonzales, C. A. Ross, J. D. Journey, Appl. Math. Model., vol. **40**, pp. 2770-2782 (2016).
4. I. Kondratenko, A. Zhiltsov, A. Bereziuk, IEEE International Young Scientists Forum on Applied Physics and Engineering (YSF), pp 247-250 (2017).

5. P. Andrienko, D. Yarymbash, Development of ore deposits, Kryviy Rih, Vol. **92**, pp. 163–167 (2008).
6. P. Andrienko, I. Kotsur, D. Yarymbash, Energetics. Vol. **3**, pp. 117–120 (2008).
7. N. Zaikina, Bulletin of the Samarskiy GTU, Series "Technical Sciences", Vol **1 (26)**, pp. 234–238 (2010).
8. N. Barka, A. El Ouafi, A. Chebak, P. Bocher, J. Brousseau, Appl. Mech. Mater., vol. **232**, pp. 730-735 (2012).
9. N. Zablodskiy, V. Pliugin. Proceedings XVI International Workshop „Computational Problems of Electrical Engineering ,CPEE 2015”, Lviv, pp. 239–241 (2015).