

Simulation of CO and CO₂ emissions in model combustion chamber based on the combination LES and Reactor Network model

Matveev S.S. , Idrisov D.V, Gurakov N.I, Gopalakrishna Gangisetty, Zubrilin I.A., Matveev S.G and Shchepakina E.A

Scientific educational center of gas-dynamics research, Samara National Research University, Samara City, Russia

Abstract. Air pollution is a major concern of recent decades, which has a serious toxicological impact on human health and the environment. It has a number of different emission sources, but one of the main sources of environmental pollutions is transported systems, in particular aviation gas turbine engines (GTE). Currently environmental issues of GTE are mainly solved by using semi-empirical techniques and experimental refinement of prototypes. In this paper we presented an algorithm for simulating the emission of CO and CO₂ in a model combustion chamber under various initial conditions and compared the results, validated with an experimental data.

1 Introduction

Air pollution is a major concern of recent decades, which has a serious toxicological impact on human health and the environment. It has a number of different emission sources, but one of the main sources of environmental pollution is transported systems in particular, aviation gas turbine engines (GTE). The International Civil Aviation Organization (ICAO) established standards for limiting the emissions of nitrogen oxides (NO_x), carbon emissions such as carbon monoxide (CO), carbon dioxide (CO₂), unburned hydrocarbons (UHC) and smoke. At the same time, it is planned to gradually strict the norms, including 60% of NO_x emissions reduction by the year 2030 (compared to 2008 norms) [1].

The combustion chamber (CC) is the most critical part of the gas turbine engine (GTE), which determines its ecological characteristics. Currently, the environmental issues of GTE are mainly solved by using semi-empirical techniques and experimental refinement of prototypes. This approach is characterized by increased time-consuming and low informative processes in combustion chamber, which does not allow ensuring the implementation of promising ICAO standards.

Perspective methods for calculating the characteristics of turbulent combustion of hydrocarbon fuels are based on the joint solution of non-stationary equations of gas dynamics and detailed chemical kinetics by direct numerical simulation (DNS) methods. However, at the present time, in such a formulation, the solution of problems with respect to combustion turbojets cannot be realized because of the limited possibilities of advanced computer technology. The solution to this problem is seen in the application of combined methods, consisting in a sufficiently accurate

solution of each subtask separately and combining them into a single algorithm. Simulation of a chemical kinetics is impossible without the use of detailed and reduced reaction mechanisms, for the formation of which it is necessary to know the exact composition of the initial fuel.

2 Experimental setup

This experiment was carried out with a single-burner modeled combustion chamber (Figure 1). The model of the combustion chamber is fixed by means of a flange (2) to the experimental installation and includes the following main elements: diffuser (1); the combustion chamber body (3); burner device (4); the body of the flame tube (5); output device (6). One of the side walls (9, 10) of the combustion chamber has a window with heat-resistant glasses (7, 8), for the possibility of visualizing the processes. The experiment was carried out at $\alpha = 1.15 \dots 1.67$ ($\alpha = l/\varphi$), initial temperature + 150 ° C and atmospheric pressure. The pressure ratio in the combustion chamber is constant maintained at $\Delta P = 3\%$.

$$\Delta P = \frac{P_{in} - P_{out}}{P_{in}} * 100\%$$

P_{in} – total pressure at inlet of combustion chamber (const);

P_{out} - total pressure at outlet of combustion chamber (const).

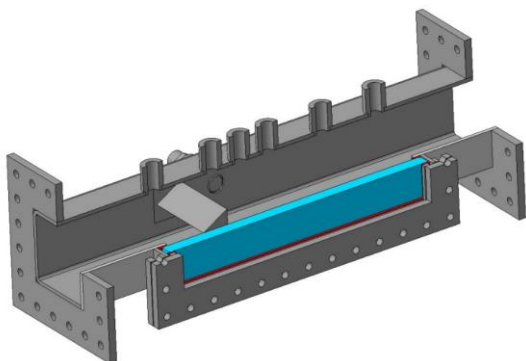

Fig. 1. Model combustion chamber.

Experimental trials were carried out at the high-temperature experimental setup with a model combustion chamber, which was described in the paper [2]. The general view of the high-temperature installation connected to the fuel line and air passage lines is shown in Figure 2.



Fig. 2. Experimental installation with a model combustion chamber
 1- the main air heater $N = 102$ Kw; 2 - two-circuit nozzle for supplying liquid and gaseous fuels; 3 - a section for preliminary preparation of the fuel-air mixture; 4 - diffuser; 5 - device for equalizing the flow; 6 - measuring section; 7 - model of the combustion chamber; 8 - output section; 9 - an exhaust shaft; 10 - ignition system power module; 11 - gas pressure regulator.

Fig. 2. Experimental installation with a model combustion chamber

The sample line consists of a sampler (1), a Richter absorber (2); a pump (3) built into the SICKGMS-810 analyzer (4), Seger pipettes (5), and a GSB-400 gas meter (6). GSB-400 is used to estimate the volume (and the flow rate) of sampled gases. The sample from the sampling point to the Seger pipettes - was pumped with a pump built into the SICKGMS-810 analyzer. This sample line configuration allowed simultaneous sample pumping via Seger pipettes, its dehydration and analysis. During sampling, the combustion products were pumped via the Seger pipettes at the flow rate of the volume equal to 20 pipette volumes. Obtained gas samples were analyzed using gas chromatography. The sampling was carried out at the output of the simulated combustion chamber. Statistical analysis of measurement errors 0.95. The error of a single measurement is $\pm 10\%$, the error in determining the mean values from the results of five experiments is $\pm 4\%$.

3 Simulation

The geometric model of the combustion chamber with an angular flame stabilizer is made like experimental model and is shown in Figure 3.

Since the geometric model of the CC has rectangular forms of the working area, in this study a structured mesh was calculated successfully, generated in an automatic mode with a total number of elements of the order of 0.4 million pieces. Since intense vortex flows are formed in the zone behind the flame stabilizer [3,4], the size of the finite elements in the corresponding regions of the CC has been reduced. The total number of items increased to 0.6 million pieces. The final calculated grid model is shown in Figure 4

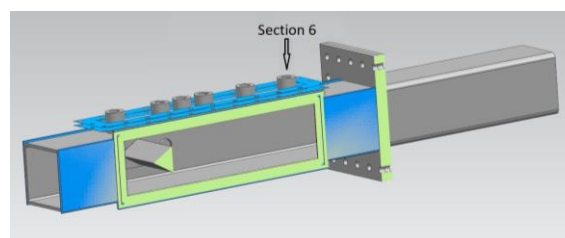

Fig. 3. Geometrical model of the combustion chamber with a corner flame regulator

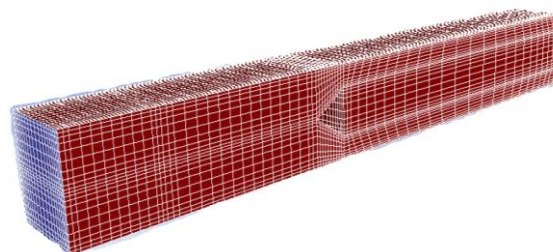

Fig.4. Grid model of the angular flame stabilizer

4 Laminar flame speed

One of the quantities characterizing the combustion process in the combustion chamber is the normal flame propagation speed S_L , which characterizes the velocity of the flame front relative to the unburned gas in a direction perpendicular to its surface. It is a fundamental characteristic of the fuel-air mixture, depending on the fuel surplus, initial temperature and pressure:

$$S_L = f(\phi, T, p, \text{fuel type})$$

Due to the fact in the standard settings of ANSYS Fluent S_L is set by a constant for the entire range of temperature and pressure values, and the results with a high error. Therefore, when determining S_L in the mathematical model of calculation, it is necessary to know its dependence on temperature and pressure. In [5], such function was obtained on the basis of numerical simulation results in the software product ANSYS ChemKin-Pro, using the kinetic mechanism of GRI 3.0 [6].

5 RANS/LES

Modes of operation of the model combustion chamber varied over a wide range in terms of the coefficient of excess air, residence time and the initial temperature of the fuel assembly. The temperature (T_c) varied from 373 to 523 K; the excess air factor (α) varied from 1.1 to 1.7; the speed at the inlet (u) varied from 3 m/s to 15 m/s. The pressure drop in the model CC with the angular flame stabilizer was $\Delta P^* = 3\%$ for the velocity $u = 10$ m/s.

The combustion of the pre-prepared fuel assembly was realized using the flamelet model. At the first stage, calculations were made in the RANS setup, which was then used to simulate the large-eddy simulation (LES) [7]. The main investigated mode of operation of the model combustion chamber was that, regime with the following initial conditions: $\alpha = 1.36$, $T_k = 423$ K. The results of calculations of the concentrations of the final combustion products of CO_2 and H_2O along the axis of the model CC, as well as their comparison with the experimental data are shown in Figures 5(a) and 5(b).

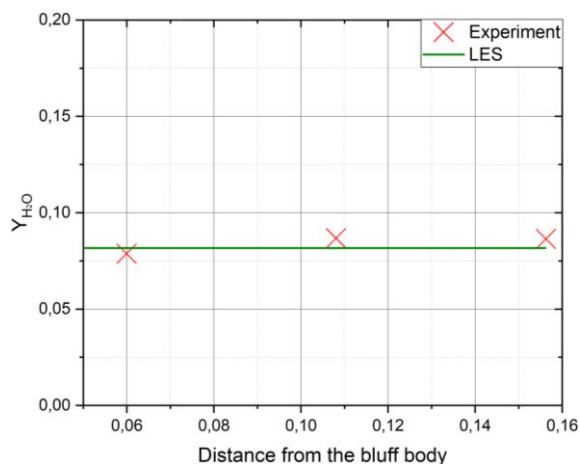

Fig.5a. concentration of H₂O

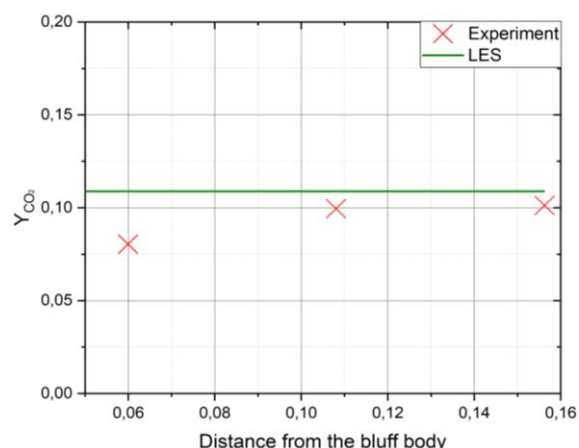

Fig.5b. concentration of CO₂

The results of the calculation showed a satisfactory agreement with the experimental data. The correct prediction of the final combustion products of the fuel guarantees an adequate temperature distribution, which is necessary for the formation of the reactor chain.

6 Reactor network

The reactor circuit is used to simulate the combustion products in the combustion chamber with the possibility of using detailed kinetic mechanisms, in particular emissions of pollutants such as NO_x, CO and unburned hydrocarbons. The combustion chamber volume is automatically broken down into ideally stirred reactors. Since the set number of reactors is much smaller than the size of the finite elemental mesh of the CFD model, the reactor models allow significantly accelerating the modeling of concentration fields. As a rule, simulation with the help of reactors is performed on a convergent stationary RANS solution or a time-averaged non stationary LES solution [7].

7 Results

Based on the calculation procedure which is described above, a study was made for the effect of the excess air factor (α), velocity and temperature of the inlet stream in the CC on the formation of carbon oxides (CO and CO₂).

The Figures 6.a, 6.b and 7.a, 7.b shows data on the effect of the air-fuel mixture composition, while the velocity and temperature of the flow at the inlet to the model CC were kept constant: $u = 10$ m/s; $T_k = 423$ K. The results of calculations in the Section no.6 of the model combustion chamber were not averaged over the whole plane, but only on the surface in the central section measuring 16x16 mm. precisely on this section 6, averaging of the experimental data obtained with the aid of the probe method of sampling was performed.

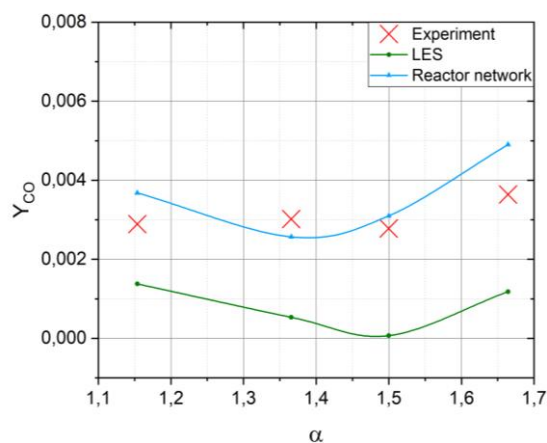

Fig.6a. Mass concentration of CO as a function of α

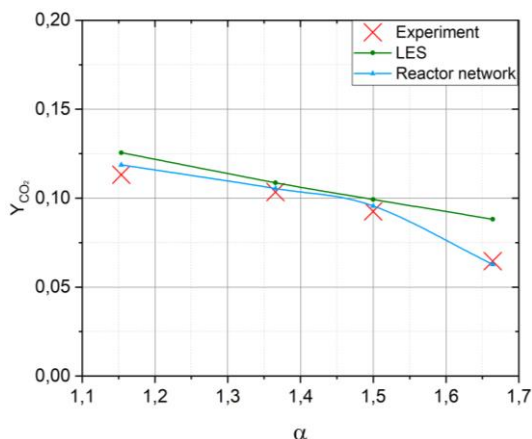

Fig.6b. Mass concentration of CO₂ as a function of α

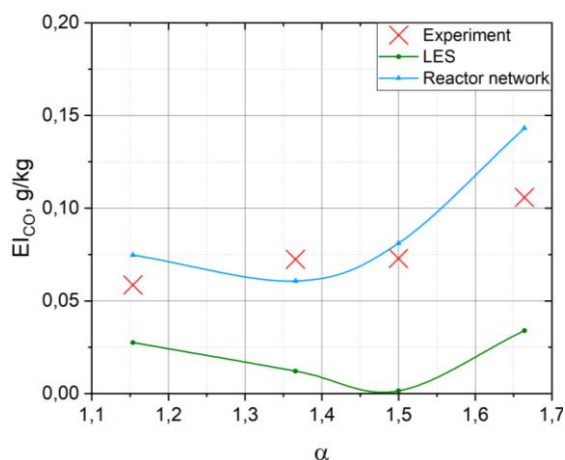

Fig.7a. CO emissions as a function of α

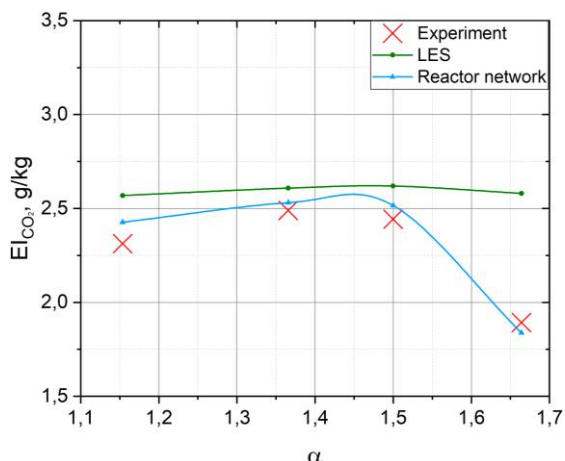

Fig.7b. CO₂ emissions as a function of α

From the experimental data shown in the Fig. 6.a and Fig. 6.b, it is seen that with an increase in α from 1.15 to 1.67, the CO emission index increases from 0.06 to 0.11 g/kg of fuel, which is associated with a deterioration in the combustion conditions of depleted pre-prepared fuel-air mixtures and corresponds to well-known tendencies. The results of calculations by the LES approach (without simulating the chain of reactors) give significantly lower levels of CO concentrations: $EI_{CO} = 0.01 \dots 0.03$ g / kg of fuel, which is 4-5 times less than the experimental data.

The use of reactor models allows a better qualitative prediction of the emission of both CO and the final product CO₂. The deviation from the experimental data on carbon monoxide (CO) for $\alpha = 1.15 \dots 1.5$ is not more than 15%, and for $\alpha = 1.67$ not more than 25%.

The influence of the flow velocity at the inlet to the model combustion chamber with the angular flame stabilizer is shown in Fig. 8.a and Fig.8.b, while the inlet temperature in the model CC and the excess air coefficient were kept constant: $\alpha = 1.36$; $T_K = 423$ K.

An increase in the flow rate leads to a decrease in the residence time of the fuel assembly in the combustion zone behind the corner flame stabilizer. This estimation shows that increasing the flow rate from 3 to 15 m/s leads to a decrease in the residence time in the zone from the corner flame stabilizer to the combustion chamber section No. 6 from 20ms to 4ms. This leads to an increase in the concentration of carbon monoxide and, accordingly, to a decrease in the final product of combustion of CO₂. This trend is not reflected in the modeling of the LES approach, while the connection of the reactor circuits allows to obtain more reliable results with a maximum deviation from the experimental data within the limits up to 10%.

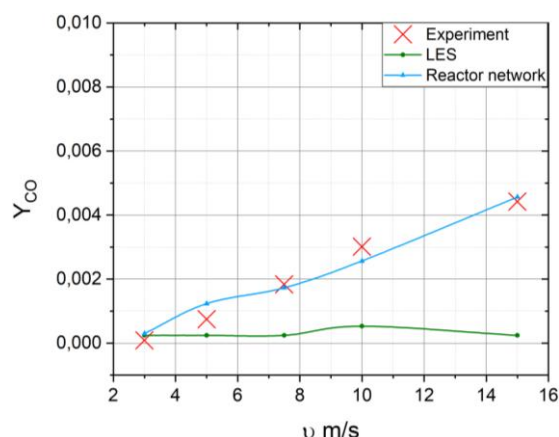

Fig.8a. Mass concentration of CO depending on initial flow rate

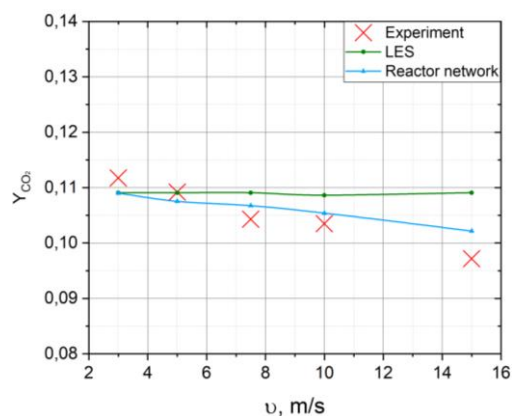

Fig.8b. Mass concentration of CO₂ depending on initial flow rate

Fig.9.a and Fig.9.b shows the effect of the initial temperature of the pre-prepared fuel-air mixture on the

formation of CO and CO₂, while the flow rate and the composition of the fuel assemblies were kept constant: $u = 10 \text{ m/s}$; $\alpha = 1.36$.

With an increase in the initial temperature, previously prepared by FA, the processes of ignition and combustion are improved, which is reflected in the experimental data obtained in this paper. An increase in temperature from 373 to 523 K leads to a decrease in the CO concentration from 0.0036 to 0.0018. Simulation using a chain of reactors as a whole with satisfactory accuracy (up to 15%) reflects the experimental data, and direct LES simulation produced significantly lower results.

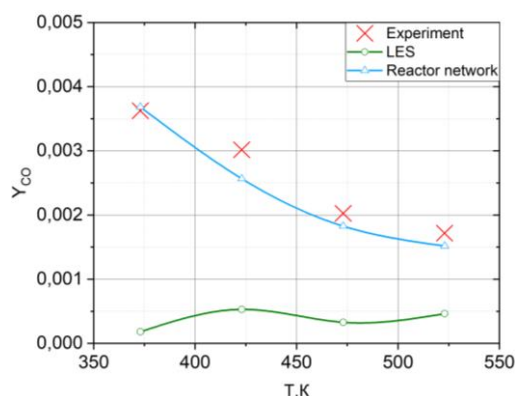

Fig.9a. Mass concentration of CO as a function of the initial flow temperature

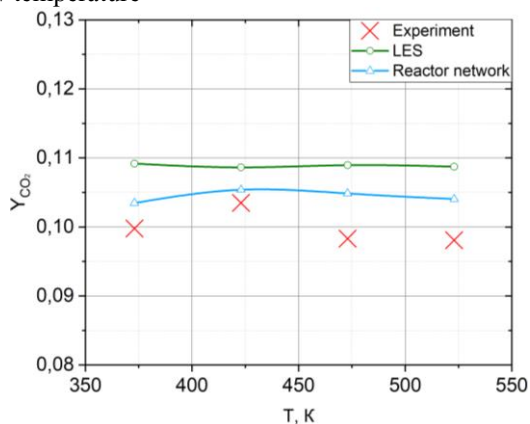

Fig.9b. Mass concentration of CO₂ as a function of the initial flow temperature

8 Conclusions

As a result of computational and experimental studies, combustion of natural gas in a model combustion chamber with an angular flame stabilizer was studied. Mathematical models of turbulence, combustion, environmental properties, and initial and boundary conditions are determined and described. The kinetic mechanism of methane oxidation GRI 3.0 was experimentally confirmed using the example of calculating the normal flame propagation velocity, and the possibility of its application to natural gas was also proved.

The algorithm for determining CO and CO₂ has been formulated and approved, in which calculations are performed in the RANS at the beginning, on the basis of which the calculation in the LES is performed. The results obtained by the LES approach show satisfactory accuracy in predicting the final products of the fuel oxidation reaction (CO₂ and H₂O), as well as the temperature distribution. The chain of reactors for combustion of the pre-prepared fuel-air mixture is formed on the basis of the temperature field obtained using the LES approach. Modeling using reactor models uses the detailed kinetic mechanism of fuel oxidation, verified with experimental results of the normal flame propagation velocity. Modeling of CO₂ and CO by this algorithm showed good agreement with the experimental results.

Acknowledgments

This work was supported by the Ministry of education and science of the Russian Federation in the framework of the implementation of the Program "Research and development on priority directions of scientific-technological complex of Russia for 2014-2020" (RFMEFI58716X0033)

References

1. International standards and recommended practice "Environmental protection". Annex 16 to the Convention on International GA, Volume 2, "Emission of aircraft engines" [Text] / Montreal, 2nd ed. 1993- 96 p.
2. Matveev, S.S., Chechet, I.V., Semenikhin, A.S., Abrashkin, V.Y., Lukachev, S.V., Matveev, S.G. Experimental Study of the Combustion of Kerosene and Binary Surrogate in the Model Combustion Chamber. Journal of Combustion, Volume 2017, Article ID 3963075, 6 pages.
3. Matveev, S.G. Modeling of the flow structure behind the flame stabilizer by the method of large eddies [Text] / S.G. Matveev, I.A. Zubrilin // Proceedings of the Samara Scientific Center of the Russian Academy of Sciences, - T. 15, - № 6-4, 2013, - p. 874-880.
4. Matveev, S.S., Zubrilin, I.A., Orlov, M.Y., Matveev, S.G., Chechet, I.V. Investigation of fuel distribution in partially premixed swirled burner with pilot flame. Proceedings of the ASME Turbo Expo 4B-2016, GT2016-57478
5. Zubrilin, I.A., Matveev, S.S., Matveev, S.G., Idrisov, D.V. Measurements and Experimental Database Review for Laminar Flame Speed Premixed CH₄/Air Flames IOP Conference Series: Materials Science and Engineering, Volume 302, Issue 1, 8 February 2018, № 012078
6. GRI-Mech 3.0, The Gas Research Institute, http://www.me.berkeley.edu/gri_mech/
7. ANSYS 18 User Guide Inc. <http://www.ansys.com/>