

Determining displacement parameters of "Kletevaya" shaft axis over mined-out space

*Albert Zubkov*¹, *Sergey Sentiabov*¹ and *Konstantin Selin*^{1*}

¹ Federal State Budgetary Institution "Institute of Mining of Ural Division of Russian Academy of Sciences", Yekaterinburg, Russia

Abstract. The development of mineral deposits very often occurs in stages. First, open-cut mining, then underground one. At the same time, the arrangement of shafts is always problematic, when it is necessary to choose between security and economic efficiency. Design solutions always convince us that the main thing is safety, but is it really so? This article is the initial stage in the formulation of a very topical issue, in the opinion of the authors, which consists in developing a method for estimating and forecasting the change in the state of shafts during operation. Experimental work was carried out at "Gaiskoe" underground mine, where seven shafts are located in operation, located 100-200 meters from the collapse zone, the depth of the trunks is more than 1300 meters. The main purpose of the research was to determine the wandering from the vertical axis of the trunk at different depths. **Key words:** stress-strain state, deformation, rock shift, control of linear parameters.

1. Brief description of the mine

"Gaiskoe" copper-pyrite mine began operating in 1959. The mine is represented by several isolated ore mines of complex lenticular and vein-like forms, differing in mineral composition. The ore-bearing formation is represented by albitophyres, tuff breccias, tuffs of basic and mixed compositions, intensively schistose and silicified.

On the basis of the mine was built "Gaiskoe mining and processing works", where 76% of the copper reserves of the Orenburg region are concentrated. In order to accelerate the involvement of rich ore in exploitation and increase the capacity of the enterprise, the development of the mine was carried out in a combined way, with the combination of open-pit and underground mining.

The first stage of the pit No.1 was commissioned in 1963 with a design capacity of 2 million tons. Simultaneously with the construction of the pit on its northern side, the construction of an underground mine was performed. The extent of the horizons at the first stage of the autopsy (with a deck height of 60 meters) was 170-440 meters.

The extent of the horizons at the second stage of the autopsy was 440 - 685 meters. When designing the second stage of the mine, it was planned to increase the production capacity several times by using self-propelled equipment.

* Corresponding author: skvekb@mail.ru

The opening was carried out by vertical shafts of the mines "Ekspluatatsionnaia", "Kletevaya" and "Zakladochnaia", access ramp and ventilation shafts. The height of deck was 80 meters, the width of chambers was 20 meters, haulage level was passed at an elevation of 685 meters from the surface. In the intermediate horizons (510, 590, 670 meters), ore from blocks was delivered using self-propelled LHD to ore passes, then the ore was transferred to production level (685 meters) and transported to the shaft in wagons.

The third stage of the mine opening provided for the penetration of intermediate horizons at 750, 830, 910 meters and a haulage level of 936 meters. Opening of the reserves was performed via vertical mine shafts "Ekspluatatsionnaia", "Zakladochnaia", "Novaia", "Sredniaia ventilatsionnaia", "Iuzhnaia ventilatsionnaia", "Severnaia ventilatsionnaia" and access ramp.

In 2006, a large-scale reconstruction of "Gaiskoe mining and processing works" OJSC underground mine shafts was commenced. Since 2012, the priority reconstructed objects of the underground mine are shafts of three mines - Kletevaya, Skipovaia and Novaia.

The "Kletevaya" mine shaft was put into operation in 2013 after reconstruction. The purpose of "Kletevaya" mine shaft is the descent of people to the elevation of 1390 meters, ensuring the operation of mine drainage, supply of compressed air and water to the mine.

2. Measuring method

At mines, there is a widespread sinking of shafts in the zone of influence and mined-out space, which includes the pit and caving area for underground mining. At the Gaiskoe mining and processing works all eight shafts turned out to be at the distance of 140 to 480 meters (on the average — 200 meters) from the side of pit No.1 and the possible caving area for underground mining operations with a diameter of 1,400 meters for a half a century of operation (Figure 1).

In the geomechanical calculation of the deviation of the axis of the shaft from the position of conductors in relation to the axis, several difficulties arose:

1. The displacement of the rock massif on mined-out space occurs in the zone of residual stress [1].
 - gravitational component causes a deformation of the expansion of mined-out space;
 - tectonic component causes its compression;
 - time variable astrophysical component [2] compresses or expands mined-out space with an average period of 11 years.

2. Deep mine shafts rarely pass in one stage. "Kletieva" mine shaft in the Gaiskoe underground mine were taking place in 4 stages since 1959 to 2012. At this time, the massif in the mining zone underwent a variety of deformations, both in magnitude and sign.

In these conditions, the geomechanical calculation of the deviation of shafts axis toward mined-out space is very problematic. It is easier to measure it instrumentally. It was done by the experimental method.

The proposed control method assumes the determination of the deviation of shaft from the vertical axis, caused by the theoretically possible displacement of the rock mass in the direction of the pit mined-out space.

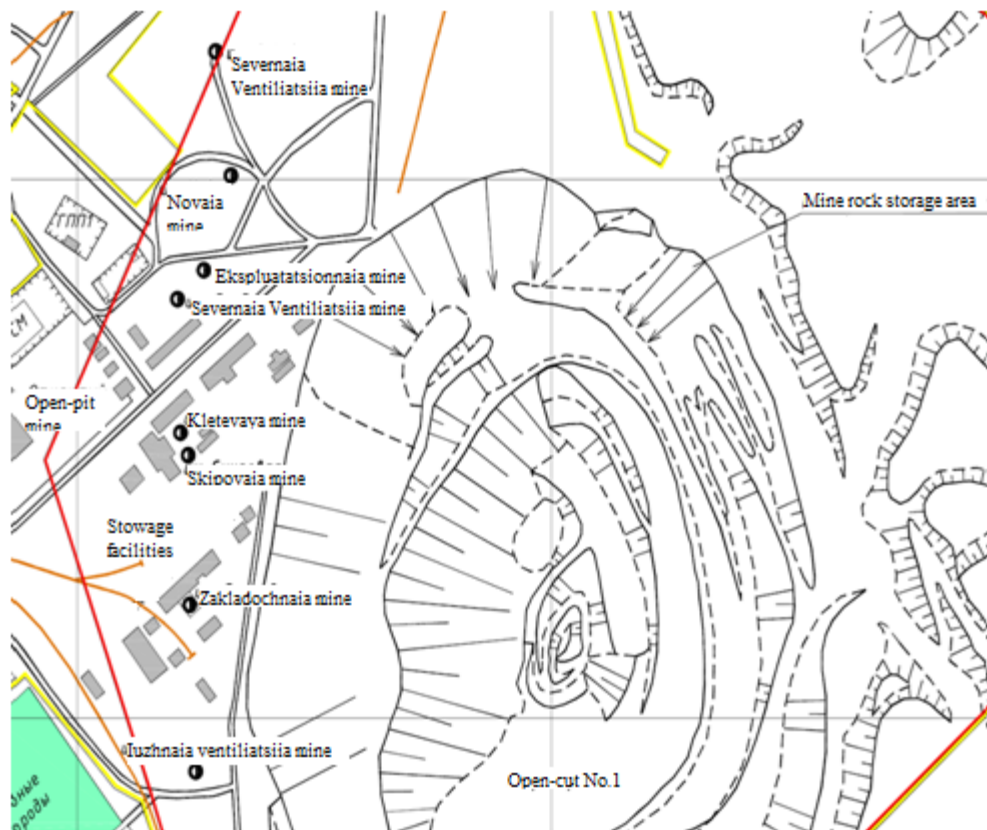

Fig. 1. Industrial site plan

The basis of the method is the determination of the mutual position of the observation stations (OS) located in the shaft of the "Kletevaya" mine, at horizons: 0; - 260 m; - 440 m; -752 m; -990 m. The mutual position control is carried out by determining the change in the linear parameters of the position of laser plumb spot on a target. The laser plumb function is performed by the precision tachymeter "Sokkia NET 1200" with a telescope at the zenith point. The function of the target is performed by an observation table made of PMMA, on which shroud sheet is fixed (Fig. 4).

The tachymeter is mounted on the console, which is attached to the H-beam of a shaft manway. The device is located under the target, consistently, on the horizons: - 990 m; - 752 m; -440 m, -260 m while the target is set at horizons: -752; - 440 m; - 260 m; 0. The scheme of tachymeter is shown in Fig. 2, 3, 4. Tachymeter is set to operating position (zenith angle of 0°), after which the spot of cross-section is marked on the target. Then tachymeter is rotated by 90° and the position of cross-section spot is again marked on the target. In total, the above-described operation is performed 4 times, then, 4 contours of the cross-section spot remain on the target with a 90° tachymeter rotation pitch. The center of the cross-section is determined by 4 contours of the spot of the cross-section. Then, linear parameters of the center position in relation to joints of the elements of the shaft furniture, in the target setting area (Fig. 4), are determined with a tape ruler. Measurements of linear parameters of the device position are performed in a similar manner.

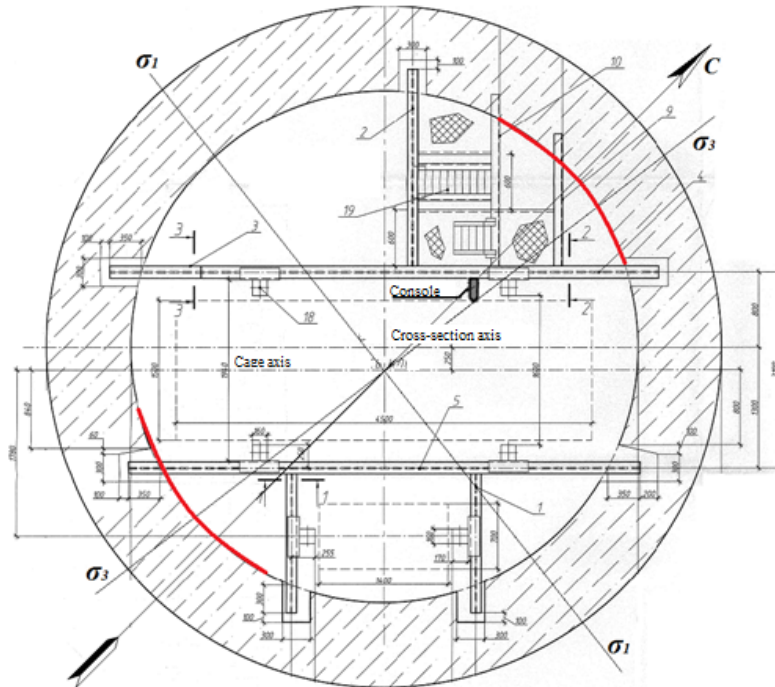

Fig. 2. The observation station of the tachymeter (console).

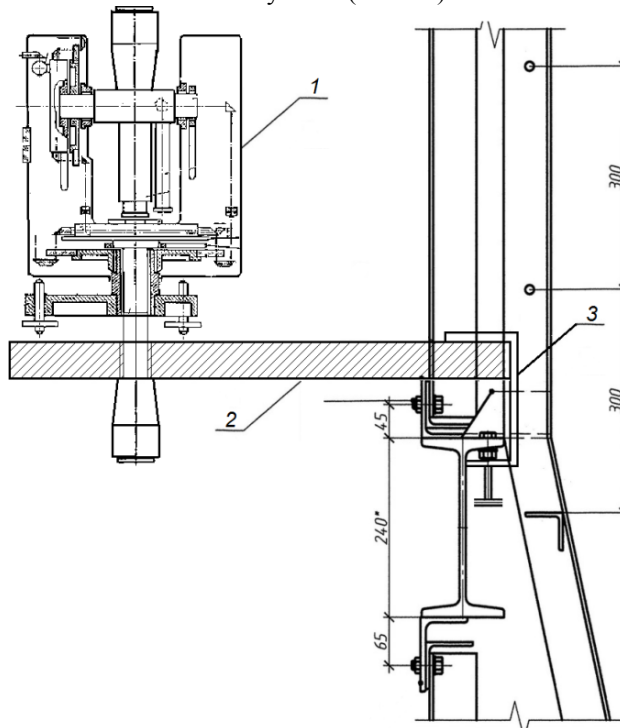

Fig. 3. Scheme of tachymeter installation, where: 1 - tachymeter; 2 - console; 3 - console attachment.

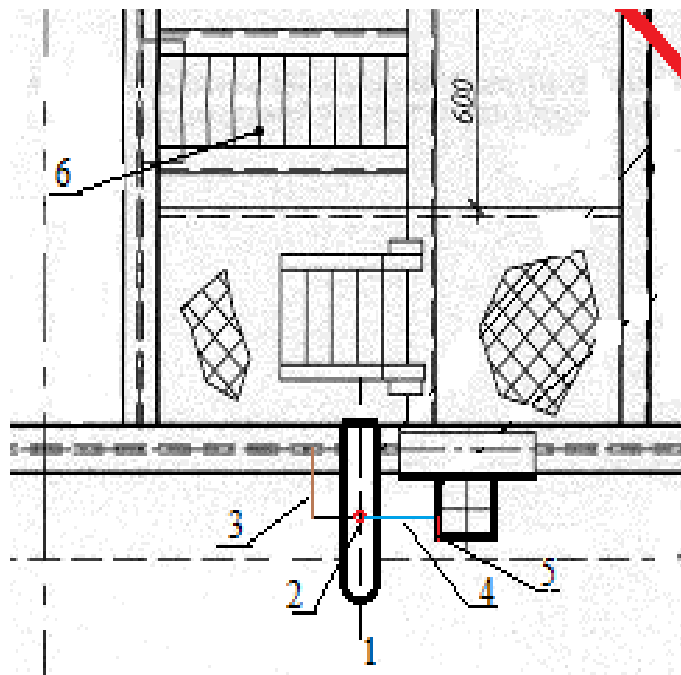

Fig. 4. Scheme for the measurement of linear parameters the position of central axis of instrument (axis of the plumb line), 1 - console; 2 - plumb line axis; 3 - distance from the axis of plumb to the center of the bunton; 4 - distance from the axis of plumb to conductor; 5 - distance from the axis of plumb to conductor surface; 6 - manway.

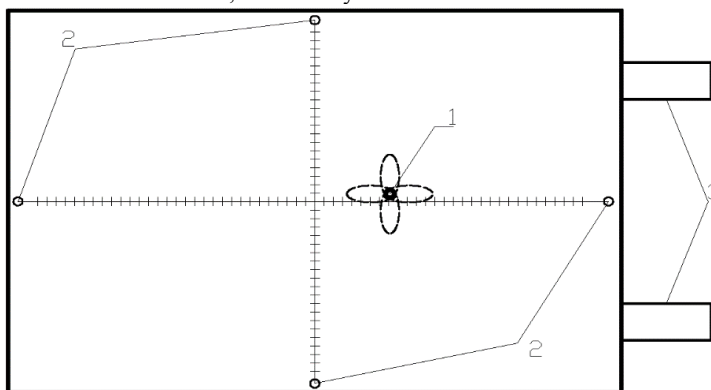

Fig. 5. The position of the spot on observation bench, 1 - cross-section spot; 2 - marks for cross-section spot position reference; 3 - bench attachment.

3. The results for monitoring parameters of "Kletevaya" mine shaft axis displacement and rock massif at Gaiskoe field

In accordance to the condition that shaft slope changes, measured linear parameters of plumb axis position relative to the reinforcement elements change. Changes in the linear parameters on the OS of all horizons may be summed to obtain the total deviation of the shaft from 0 to -990 m.

According to the paragraph No.324 [3], permissible deviation of the shaft axis is calculated by the formula:

$$\Delta U_p = (50 + 0.15H), \text{ mm}$$

H - shaft depth (in area under calculation), m.

For "Kletevaya" shaft at the area of 990 m, the maximum deviation will be 198 mm.

The results of three observations series for determining the position of shaft axis are given in Table 1 and in Fig. 6.

Table 1. The results of observations

Stage / Date	June 2014 X / Y (mm)	October 2014 X / Y (mm)	July 2017 X / Y (mm)
-10/-260	266 / 7	398 / 26	431 / 2
-260/-440		307 / 5	330 / 1
-440/-752	190 / 39	208 / 75	233 / 49
-752/-990	-	45 / 4	60 / 11

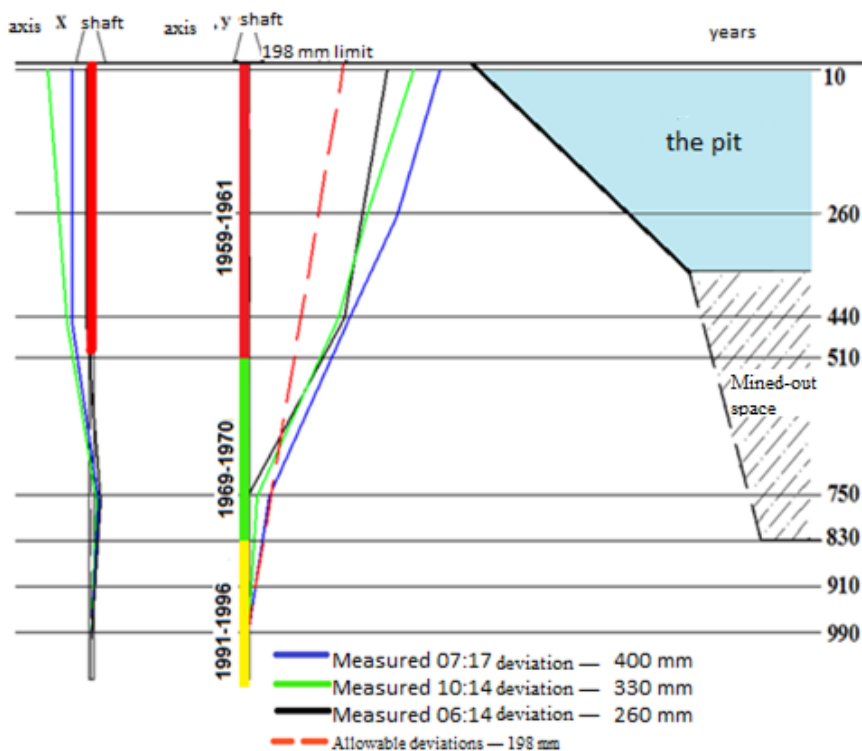

Fig. 6. The results of determining the position of "Kletevaya" shaft axis

As a result of the studies, the general trend of the shaft axis wandering was confirmed. The total inclination of the axis towards mined-out space was 400 mm (along the "Y" axis), with an allowable deviation of 198 mm (in accordance with paragraph No.324 [3]). The measurements were carried out according to the methodology developed by the Institute of Mining of the Ural Division of the Russian Academy of Sciences, which was not certified at the moment. The proposed method of stage measurements, unlike traditional methods [4], allows us to quickly detect the deviation of shaft axis from the allowable limits at any intervals. The proposed theoretical methods allow calculating massif deformation around the caving area when limited conditions are gravitational and gravitational-tectonic stresses which are constants for the whole period of the enterprise's operation [5].

It has been established for now that the residual stresses of the rock mass form gravitational ($\sigma_{\gamma H}^n$), tectonic (σ_T^n) and the astrophysical component (σ_{Af}^n) which is time-dependent, with a cyclicity of 11 years [1]. This circumstance fundamentally changes the idea of the regularities in the development of the processes of displacement of the rock massif into mined-out space, which the world science has not considered.

The deviation of the shaft axis towards mined-out space was formed under the following conditions:

1. Up to a mark of -510 m, the shaft was conducted during 1959-1961, when there was no open-pit and no underground excavations were in progress, $\sigma_{Af}^n = 0$;
2. Deeping from -510 to -830 m was carried out in 1969-1970, during the period when cleaning works in the pit and underground were conducted. The displacement of the shaft axis during this period occurred within the framework of the factors of the change in the parameters of the stress-strain state, as a reaction to the formation of mined-out space, when the sums of gravitational ($\sigma_{\gamma H}^n$) and tectonic (σ_T^n) stresses act in the array, when $\sigma_{Af}^n = 0$. At the surface, where $\sigma_{\gamma H}^n = 0$, the displacement was smaller than at the depth;
3. 3. Deeping from -830 m to -1150 m was carried out from 1991 to 1996, when σ_{Af}^n increased from zero to a maximum;
4. In 2014 mined-out space at the mine was formed up to the mountains (-830 m). As a result, the displacement of the shaft axis in the interval -750 ÷ -830 m was minimal, and at an interval of -510 ÷ 440 m the displacement increased, closer to the surface it should become larger, which was confirmed during the experiment.

4. Conclusions

The main conclusions obtained during the work are as follows.

1. The change in the parameters of the stress-strain state of the rock massif in time radically changes the notion of the regularities in the development of the processes of displacement of the rock mass to mined-out space, which necessitates a change in the approaches to the assessment of the location and parameters of the actual state of shafts and other capital mine workings.
2. Instrumental measurements were made of the deflection of the shaft of "Kletevaya" mine from the vertical axis at various horizons, the value of which at the surface reached 400 mm, with permissible 198 mm for the depth 990 m.
3. An analogous situation with the inclination of the shafts should be observed in the fields where they start or have started underground mining, which is produced at depths of more than 500 m.
4. The proposed method of stage measurements, unlike traditional methods, allows us to quickly detect the deviation of the shaft axis from the allowable limits at any intervals.

References

1. A.V. Zubkov, *Lithosphere*, **5**, 146 - 151 (2016).
2. A.V. Zubkov, K.V. Selin, S.V. Sentyabov, *Lithosphere*, **6**, 116 - 129 (2015).
3. Instructions for the production of surveying work, RD 07-603-03.
4. I.I. Dobkin, V.B. Lebedev, M.N. Galinskaya, E.D. Platonov, Yu.V. Anufriev, *Mine surveying for the installation and operation of mine hoisting equipment*, 221 (1983).
5. A.D. Sashurin, *Movement of rocks in the mines of ferrous metallurgy*, 268 (1999). The work was carried out within the framework of the state task (subject №0405-2015-0012).