

Solar Water Heating System for Biodiesel Production

Syaifurrahman^{1,*}, A Gani Usman¹, and Rakasiwi Rinjani^{2,*}

¹Department of Electrical Engineering, Faculty of Engineering, Tanjungpura University, Pontianak- Indonesia

²Department of Chemical Engineering, Faculty of Engineering, Tanjungpura University, Pontianak - Indonesia

Abstract. Nowadays, electricity become very expensive thing in some remote areas. Energy from solar panels give the solution as renewable energy that is environment friendly. West Borneo is located on the equator where the sun shines for almost 10-15 hours/day. Solar water heating system which is includes storage tank and solar collections becomes a cost-effective way to generate the energy. Solar panel heat water is delivered to water in storage tank. Hot water is used as hot fluid in biodiesel jacked reactor. The purposes of this research are to design Solar Water Heating System for Biodiesel Production and measure the rate of heat-transfer water in storage tank. This test has done for 6 days, every day from 8.30 am until 2.30 pm. Storage tank and collection are made from stainless steel and polystyrene a well-insulated. The results show that the heater can be reach at 50°C for ±2.5 hours and the maximum temperature is 62°C where the average of light intensity is 1280 lux.

1 Introduction

Energy always becomes important issue. Renewable energy of the sun is generated from the nuclear fusion of its hydrogen into helium, with resulting mass depletion rate of approximately 4.7×10^6 tons per second and solar radiation reaches the earth on a continuous basic amount to 120,000 terawatts [1]. Solar energy is fast becoming a welcome alternative source and hazard free heat source, especially in the tropics [2]. West Borneois in Equator line where the power of sunlight reaches $\pm 1000 \text{ W/m}^2$ [3]. The solar radiation incident on the surface of the earth can be conveniently utilized for the benefit of human society. One of the popular devices that harness the solar energy is solar hot water system [4]. Biodiesel as renewable energy is made by trans-esterification reaction at $40\text{-}65^\circ\text{C}$ [5]. In 2014, West Kalimantan has product 1.9 billion ton/year of crude palm oil which can produce become biodiesel.

Electricity generate from solar only 0.88 MW from 1.1×10^9 MW of solar energy potential in Indonesia. Solar water heating has been around for many years because it is the easiest way to use the sun save energy and money. Solar water heater do not pollutes. Solar water heater help to avoid carbon dioxide, nitrogen oxides, sulphur dioxides and the other air pollution and wastes created when the local utility generates power or fuel is burned to heat domestic water. When a solar water heater replaces an electric water heater, the electricity displaced over 20 years represents more than 50 tons of avoided carbon dioxide emissions alone [6].

Implementation for the idea is by design biodiesel unit using solar heater with no electricity needed. Heat of trans-esterification reaction can fill using hot water from solar heater. Mini unit of biodiesel production using solar water heating system is a simple and environment friendly technology. Hot water is used as hot fluid in biodiesel jacked reaction. Some areas which developing countries have used solar water heating system for trans-esterification reaction and to evaporate drying water in 4m^2 solar collections for 19 litres each day of biodiesel [7].

Solar water heating system consists of storage tank and solar collection. There are two types of solar water heating system: active and passive. Active types have circulation pump and control, and passive, which don't. Passive solar water heaters rely on gravity and the tendency for water to naturally circulation as it is heated. The systems contain no electrical components are generally more reliable, easier to maintain, and possibly have a longer work life than active solar water heater systems. Most solar heaters require a well-insulated storage tank and have an additional outlet and inlet connected to and from the solar collector [6].

Solar water heating system can save 40-80% on electric or fuel. A solar energy incident on the absorber panel coated with selecting transfer to the riser pipes underneath the absorber panel. The water passing through the risers get heated up and is delivers the storage tank. The choice of system depends on heat requirement, weather condition, heat transfer fluid quality, space availability, annual solar radiation The solar water heater system are pollution free and easy for operation. A 100 litres capacity

*Corresponding author: rinjani_s@yahoo.com

solar water heater can replace an electric geyser for residential uses and saves 1500 units of electricity annually. The use of 1000 solar water heater of 100 litres capacity each can contribute to a peak load saving of 1 MW. A solar water heater of 100 litres capacity can prevent emission of 1.5 tonnes of carbon-dioxide per year [8].

This technology can apply in some remote area where there is no electricity. In West Borneo border side area, it is hard to reach some accommodation and transportation. Fuel becomes very expensive and rare things. The objective of this paper is to design and test solar water heating for biodiesel production. Solar water heater is design using generous material. Therefore we can produce renewable fuel with no electricity needs.

2 Methodology

There are two main steps that have been done in this research.

1. Designing solar water heating system
2. Testing the solar water heating system

Solar water heating system is made by using economy materials. Solar water heating system for biodiesel production consists of solar collection and storage tank. Type of solar heater is passive solar water heater with Thermosyphon system. Type of collector systems is called evacuated tube solar collector

The materials that have been used are:

1. Stainless steel storage tank
2. Stainless steel tubes
3. Stainless steel pipes
4. Acrylic glass
5. Foam
6. Aluminium foil
7. Valve
8. Black color
9. Nut-bolt
10. Elbow
11. Glass glue

Measuring instrument that have been used are:

1. Thermometer
2. Luxmeter

Water flows into the stainless steel pipe absorbed heat from solar. Hot water will be up stream into storage. Hot water then flow to biodiesel jacket-reactor.

Solar water heating system then is tested on the second floor of laboratory building which has outdoor space. Water flows into the inlet of collector solar water heater fixed to and the temperature in tube, atmosphere temperature and light intensity are measured.

The test was held in the Basic Electrical Laboratory, Engineering Faculty of Tanjungpura University for 5 hours each day. Solar water heating system is tested on clear sunny days for 6 day.

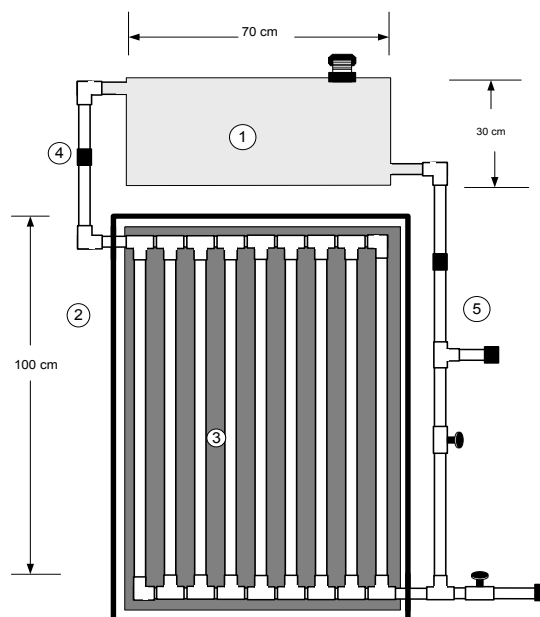

Fig.1. Design of Solar Water Heating System

Solar water heating system for biodiesel production parts: (1) Storage tank; (2) Solar collection; (3) Tubes; (4) Up-stream; (5) Down-stream.

3 Results and Discussion

3.1 Design of Solar Water Heating System

Solar collector is design for commercial application. Design for evacuated-tube collectors is small capacity and collecting surface. In a thermosyphon system there is no circulation pump and controller. Potable water flows directly to the tank on the roof. Solar heat water flows from the rooftop tank to the trans-esterification reactor. The result of design shows at Fig.1. The details of the design are:

1. The capacity of storage tank is proximally 50 litres. Storage tank is covered by foam and aluminium foil to save the heat well.
2. Solar collecting surface are proximally 7m².
3. They are 8 stainless steel-tubes which are colored black. The tubes are designed to deliver higher temperature. Hot and cool water flow using valve as control utility.
4. Acrylic glass is using as absorber tube.
5. Polystyrene as an isolator to inhibits radiation heat loss. Side of polystyrene face to the tube is colored black to increasing of solar absorption to the water in the tube.



Fig.2. Solar water heating system for biodiesel production

Hot water will be up stream into storage tank because of different density between hot and cool water. As the sun shines on the collector, the water inside the collector flow tubes is heated. As it heats, this water expands slightly and becomes lighter than cold water. Gravity then pulls heavier, cold water down from the tank and into the collector inlet. The cold water pushes the heated water through the collector outlet and the top of the tank, thus heating the water in the tank [4]. Acrylic glass is using because can trapped sun radiation inside the box as the solar water heater is able to provide the hot water even in cloudy days [5].

Fig 2 shows that water flows directly to the tank on the roof. Solar heated water flows from the rooftop tank to the reactor. Hot water will be up stream into storage. Hot water then flow to biodiesel jacket-reactor. Energy from hot water is being used for trans-esterification reaction to produce biodiesel from crude palm oil. The water that has been used than flows to the tube of collector and get heats again. Water temperature increases along with increasing of its density. Hot water than flows to the storage tank and cold water down to the collector and so on until becomes a circle.

3.2 Performance of Solar Water Heating System

Solar water heating system is tested for 6 days, every day from 8.30 am until 2.30 pm. The heater can be reach at 50°C for ±2.5 hours and the maximum temperature is 62°C where the average of light intensity is 1280 lux. The different temperature between outside and inside tube is ±20°C shows in **Table 1**.

Table 1. Solar water heating system temperature

Day	Heating time (hr)	T _{max} Tube (°C)	T _{max} atm (°C)	Light Intensity max (Lux)
1	6	50.3	34.4	1186
2	6	54.7	35.0	1280
3	6	54.4	35.9	1172
4	6	55.0	36.1	1164
5	6	53.4	36.3	1123
6	6	62.0	37.8	1020
6	6	62.0	37.8	1020

Solar water heating system fixed to the roof of the building where the sun heat can absorbed optimally as shows at **Fig 3**. The sun shines unstable for each day and therefore reduces temperature of water in tubes.



Fig.3. Solar water heating system position when was being tested

Solar collectors capture the sun's electromagnetic energy and convert it to heat energy. The efficiency of a solar collector depends not only on its materials and design but also on its size, orientation and tilt. Solar energy is its maximum at noon, when the sun is its highest point in its daily across the sky. Certain material absorbs more insulation than others. More absorptive material are generally dark with a matte finish, while more-reflective materials are generally lighter coloured with a smooth or shiny finish. The best tilt angle will vary not only with collector's geographical location but also with seasonal function. Solar water systems are designed to provide heat year-round.

Solar water heating is now a mature technology which can be attained 60-80°C. Solar water heating system can reach at 62°C shows that hot water from the system can be use as hot fluids for trans-esterification reaction.

Though the initial investment for a solar water heater is high compared to available conventional alternatives, the return on investment has become increasingly attractive with the increase in price of conventional energy.

Conclusion

Solar water heating system that has been design using thermosyphon system with evacuated-tube collectors can reaches 50°C for ±2.5 hours and maximum temperature is 62°C that can be used for biodiesel production.

The efficiency of a solar collector depends not only on its materials and design but also on its size, orientation and tilt

We are very grateful to the Ministry of research, technology and higher education in funding the research.

References

1. H. Bradke, C. Doetsch, H. Huhn, et al., Researching: energy, brochure, Aliance

- of Scientific Organizations, Germany, 2011.
2. Okafor, Basil. *Thermo Siphon Solar Water Heater*. IJET, Vol3 No3 (2013).
3. C. Philibert. *Solar Energy Perspectives, Renewable Energy Technologies*, French: International Energy Agency. (2014).
4. Gangane, S.D, Bhere, S.H, et al. *Economical Solar Water Heater*. IOSR-JMCE, PP 68-71 (2017).
5. C. Clifford. *The Reaction of Biodiesel: Trans-eterification*.The Pennsylvania State University. (2017). [7] Wasley. *Design of a Small-Scale Biodiesel Plant*. Bellairs Reasearch Institute: McGill University. (2015).
6. C. Homola. *Solar Domestic Hot Water Heating Systems Design, Installation and Maintenance*. Solar Rating and Certification Corporation.(2014).
7. Verma, Abhishek, Kumar, Vishal. *Solar Water Heating System*. IJRAME. **Vol 3 Issue 1**, Pgs 53-63 (2015).
8. Ogie, Nosa. Oghogho Ikponmwosa, Jesumirewwhe. Design and Construction of a Solar Water Heater Based in the Thermosyphon Principle. JFREA. **Vol.3**, 8 (2013).