

Roles of K_2O on the CaO-ZnO Catalyst and Its Influence on Catalyst Basicity for Biodiesel Production

*Luqman Buchori, I. Istadi**, P. Purwanto, Louis Claudia Marpaung, and Rahmatika Luthfiani Safitri

Department of Chemical Engineering, Faculty of Engineering, Diponegoro University, Semarang - Indonesia

Abstract. This research aimed to study the effect of K_2O impregnation on the basicity of the CaO-ZnO catalyst and its effect on biodiesel production. The effect of mole ratio of CaO to ZnO catalyst and %wt K_2O were also studied. The mole ratio of CaO to ZnO catalyst was varied at 1:1, 1:1.5, 1:2, 1:3, and 3:1, while the %wt K_2O was varied at 1, 3, and 5 %. The catalyst basicity was determined by titration method. The basicity of the catalyst increased after the CaO-ZnO catalyst was impregnated with K_2O in all mole ratios of CaO-ZnO catalyst. The addition of K_2O as a promoter also increase the basicity. The highest basicity was obtained at the CaO-ZnO mole ratio of 3:1 and 5%wt K_2O . The transesterification process was carried out in a batch reactor at a methanol to oil mole ratio of 15:1, a reaction temperature of 60°C, a reaction time of 4 h, and a catalyst loading of 5%wt oil. The FAME yields obtained were 41.33%. These results proved that K_2O plays a role in enhancing the catalyst basicity. In addition, K_2O also serves as a binding agent to improve the mechanical properties of the catalyst.

1 Introduction

Biodiesel is an alternative fuel produced from vegetable oils or animal fats. Biodiesel consists of fatty acid methyl ester (FAME) which is a free fatty acid from vegetable oils and animal fat [1]. Biodiesel has lower emissions than diesel oil [2]. Biodiesel can be produced from sources of free fatty acids (feedstock) such as palm kernel oil, sunflower seed oil [3], soybean oil [4], rapeseed oil [5] and some other oils.

Biodiesel can be produced by transesterification using the homogeneous catalyst (acid or base), heterogeneous (solid catalyst) or enzyme [6]. Transesterification using solid heterogeneous catalysts has several advantages such as easier separation and purification processes due to different phases of the product, no water in the neutralization process, non-toxic, non-corrosive, low-cost, and easily regenerated [7–9]. Solid-base heterogeneous catalysts have higher effectiveness than acid and enzyme catalysts. This is due to the reaction rate of biodiesel production using heterogeneous catalyst is faster than acid catalyst [10]. However, the basic heterogeneous catalysts have some weaknesses such as lower yield, less activity and catalytic selectivity [11], leaching or dissolving the Ca active component in methanol [12, 13].

One of the catalysts developed is a metal oxide [2, 7, 14]. Potentially oxide base catalysts for the production of FAME include ZrO_2 , TiO_2 , ZnO, CaO, and SrO [15]. The higher the basicity of the catalyst, the higher the yield of FAME. The catalytic activity of the catalyst can be increased with the support of the catalyst [16].

Alkaline earth metal oxide is one of the catalysts used as a support, including ZnO, MgO, and BaO.

Istadi *et al.* [17] have prepared a basic solid catalyst with CaO as an active component. The catalyst is combined with ZnO by co-precipitation to increase the catalyst surface area and promoted with potassium oxide (K_2O) by impregnation to enhance its basicity. The results show that ZnO and CaO-ZnO catalysts have lower catalytic activity than K_2O /CaO-ZnO catalysts. However, in this research has not been an investigation to determine the effect of CaO, ZnO, and K_2O composition on catalyst activity and its effect on catalyst basicity. The mole ratio of CaO and ZnO on the catalyst and K_2O impregnation are thought to affect the crystal structure which results in the catalyst basicity so as to influence the yield of obtained biodiesel.

This research focused on studying the role of K_2O in CaO-ZnO catalyst at various mole ratios of CaO:ZnO and the effect of K_2O composition in K_2O /CaO-ZnO catalyst on the catalyst basicity and its influence in the transesterification process of soybean oil into biodiesel.

2 Materials and method

2.1 Materials

As the raw material in this research were soybean oil and methanol (99.9% Merck). Soybean oil was purchased from the local market. The chemical for the preparation of the catalyst comprises calcium nitrate tetrahydrate ($Ca(NO_3)_2 \cdot 4H_2O$) (Merck, 99%), zinc nitrate hexahydrate ($Zn(NO_3)_2 \cdot 6H_2O$) (Merck, 98.5%), potassium nitrate (KNO_3) (Merck, 99%), sodium

* Corresponding author: istadi@live.undip.ac.id

carbonate (Na_2CO_3) (Merck, 99%), and sodium hydroxide (NaOH) (Merck, 99%).

2.2 Preparation of $\text{K}_2\text{O}/\text{CaO}-\text{ZnO}$ catalyst

The preparation of the catalyst was carried out by co-precipitation method followed by impregnation. $\text{CaO}-\text{ZnO}$ catalysts with mole ratios of $\text{CaO}:\text{ZnO}$ 1:1, 1:1.5, 1:2, 1:3, and 3:1 were prepared by dissolving calcium nitrate ($\text{Ca}(\text{NO}_3)_2$) 1 M and zinc nitrate ($\text{Zn}(\text{NO}_3)_2$) 1 M into the distillation water. Then, these solutions were mixed inside the beaker glass. Furthermore, 2 M Na_2CO_3 solution was drop wise into the mixed solution with constant stirring to form a white suspension. pH was adjusted by adding 1 M NaOH solution. Stirring was done for 24 hours at a temperature of 60°C . The suspension was then filtered and washed with distillation water until it was alkaline free. The resulting solid was dried in the oven at a temperature of 110°C overnight. The result was then calcined in box furnace (Ney Vulcan 3-550) at a temperature of 800°C for 3 hours resulting in a $\text{CaO}-\text{ZnO}$ catalyst. The $\text{CaO}-\text{ZnO}$ catalyst was impregnated with 1 M KNO_3 solution while stirred and then dried in the oven at 110°C overnight. Furthermore, dry solids were calcined at 300°C for 5 hours in box furnace (Ney Vulcan). The obtained results were $\text{K}_2\text{O}/\text{CaO}-\text{ZnO}$ catalyst.

2.3 Testing of the catalyst basicity

The catalyst basicity was determined using titration method as conducted by Tanabe and Yamaguchi [18]. Half grams of catalyst were dissolved in 20 ml of benzene then dropped 3 drops of bromothymol blue indicator. The mixture was stirred for 30 minutes to form a suspension. The catalyst sample suspension was changed from yellow dye to green-blue color. The catalyst suspension was then titrated with benzoic acid while stirring at a fixed rate. The green color of the solid particle gradually disappeared. Titration was stopped when all the green color disappeared. Basicity could be calculated by equation (1)

$$\text{Basicity} \left(\text{mmol} \cdot \text{g}^{-1} \right) = \frac{(V \times N)_{\text{benzoic acid}}}{W_{\text{catalyst}}} \times 100 \% \quad (1)$$

2.4 Testing of catalysts on the biodiesel production

The experimental apparatus for the transesterification process of soybean oil over a $5\% \text{K}_2\text{O}/\text{CaO}-\text{ZnO}$ catalyst was shown in Figure 1.

Methanol and oils with a mole ratio of 15:1 and a catalyst of 5% by weight of oil were heated to 60°C and kept constant for 4 hours. The transesterification process takes place inside this three neck flask. After the transesterification reaction was complete, the three neck flask was cooled. The resulting product was then inserted in a separating funnel and held for 24 hours to form 3 layers consisting of a top layer (methanol), a middle layer (methyl ester), and a bottom layer (glycerol

and catalyst). The middle layer was taken and analyzed using Gas Chromatography-Mass Spectrometry (GC-MS).

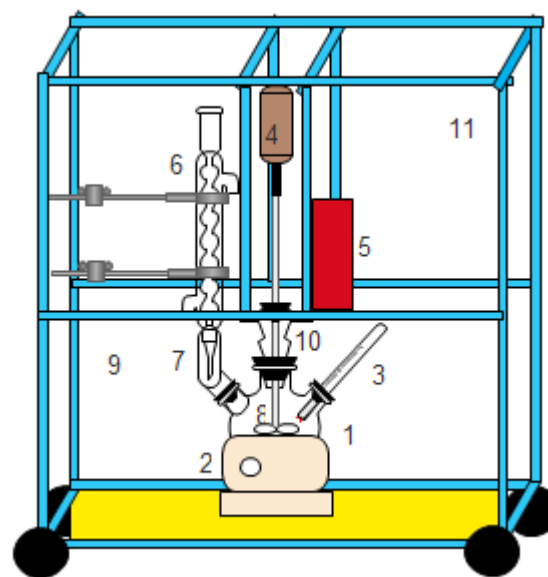

Fig. 1. The experimental apparatus for the transesterification process: (1) three-neck flask, (2) heating mantle, (3) thermometer, (4) driver motor, (5) controller motor, (6) condenser reflux, (7) elbow, (8) stirrer, (9) stative and clamps, (10) shell, and (11) portable frame

3 RESULTS AND DISCUSSION

3.1 The effect of mole ratio of $\text{CaO}:\text{ZnO}$ on the catalyst basicity

The catalyst basicity was performed by titration method using benzoic acid and benzene solvent with bromothymol blue (BTB) as an indicator. The results of the catalyst basicity before and after impregnation showed in Table 1.

Table 1. The catalyst basicity before and after impregnation with $5\% \text{K}_2\text{O}$

Mole ratio of $\text{CaO}:\text{ZnO}$	Catalyst basicity (mmol/g)	
	Before impregnation	After impregnation
1:1	0.344	0.504
1:1.5	0.260	0.316
1:2	0.164	0.280
1:3	0.088	0.230
3:1	0.662	1.090

Table 1 shows that the larger mole of CaO in the $\text{CaO}-\text{ZnO}$ catalyst leads to an increase in the catalyst basicity. This is due to the calcium oxide (CaO) has higher basic strength than ZnO [12]. In the periodic table, the Ca atoms are to the left of the Zn atom so that the radius of the Ca atom is larger and its base strength is also higher than the Zn atom. As a result, the greater the mole ratio of CaO in $\text{CaO}-\text{ZnO}$ mixed metal oxide, catalyst basicity would increase.

Based on Table 1, the increase of ZnO mole in a CaO-ZnO catalyst would decrease the basicity. This is due to ZnO is a buffer/support component in the catalyst. ZnO plays a role in increasing surface area, porosity, mechanical properties, and catalyst stability, while the increase of basicity is the role of an active component of catalyst that is CaO [19]. Thus, the increase in CaO mole in the catalyst can improve alkalinity, however, the addition of ZnO leads to a decrease in the catalyst basicity. Table 1 shows that the catalyst with the mole ratio of CaO:ZnO 3:1 has the highest basicity, while the catalyst with the mole ratio of CaO:ZnO 1:3 has the lowest base.

3.2 Effect of K₂O impregnation on catalyst basicity

In this study, impregnation of the CaO-ZnO catalysts with K₂O was also investigated. The impregnation was performed by varying %wt K₂O. This study aims to determine the effect of the addition of K₂O to the catalyst basicity. Variation of % wt K₂O was performed on the CaO-ZnO catalyst with the mole ratio of CaO:ZnO 3:1 because previously the highest basicity was achieved in the CaO:ZnO mole ratio of 3:1. The K₂O impregnation on the CaO-ZnO catalyst is varied from 1, 3, and 5%. The catalyst basicity was determined by titration method using benzoic acid and benzene solvent with bromothymol blue (BTB) as an indicator [18]. The result of catalyst base test with the variation of wt% K₂O is presented in Table 2.

Table 2. The basicity catalyst of CaO(3)-ZnO(1) with variable of %wt K₂O

%wt K ₂ O	Basicity (mmol/ g)
1%	0.48
3%	0.856
5%	1.09

Table 2 shows that the greater the K₂O component in the catalyst, the catalyst basicity will increase. The K₂O component has a primary function as a binding agent which aims to improve the mechanical properties of the catalyst. K₂O as a binder serves to bind the catalyst components of the CaO-ZnO to be made as a pellet catalyst and also increase the activity, selectivity and desired stability effect [13, 17]. Table 2 also shows that the higher the content of K₂O in the catalyst, the higher the catalyst basicity. This is due to K₂O is a promoter designed to help the active components of CaO so that the increase of K₂O in the catalyst may enhance the presence of CaO as the active site of the catalyst. Therefore, the addition of K₂O component as a promoter in CaO-ZnO catalyst is necessary because it has a dual function that is to improve the mechanical properties (as a binder) and to increase the catalyst base.

3.3 Testing of 5%K₂O/CaO-ZnO catalyst for biodiesel production

The catalyst test was performed with the following process parameters: mole ratio of methanol:soybean oil of 15:1, catalyst loading of 5%wt oil, 4 hours reaction time, 60°C reaction temperature, and constant stirring. The biodiesel product is then analyzed by GCMS to determine the composition of FAME. Yield of FAME and biodiesel are calculated using equations (2) and (3). From the results of GCMS analysis, the yield of FAME and biodiesel were presented in Table 3.

$$Yield_{FAME} = \frac{\% FAME \text{ GC Area} \times \rho_{biodiesel} \times V_{biodiesel}}{\text{weight of soybean oil feed}} \times 100 \% \quad (2)$$

$$Yield_{biodiesel} = \frac{\rho_{biodiesel} \times V_{biodiesel}}{\text{weight of soybean oil feed}} \times 100 \% \quad (3)$$

Table 3. The results of 5%K₂O/CaO-ZnO catalyst testing for biodiesel production

Mole ratio of CaO:ZnO	% FAME GC Area	Yield of FAME (%)	Yield of biodiesel (%)
3:1	97.88	41.327	42.222

According to SNI, the minimum %FAME in biodiesel is 96.5%. Table 3 shows that the obtained biodiesel contains %FAME of 97.88%. This result fulfills the SNI standard [20]. The biodiesel product is also analyzed for viscosity, density, and acid number. The results are indicated in Table 4.

Table 4. Result of characterization of biodiesel product

Mole ratio of CaO:ZnO	Kinematic viscosity (mm ² /s)	Density (kg/m ³)	Acid number (mg KOH/gr sample)
3:1	4.597	874	0.4937
SNI of Biodiesel	2.3-6	850-890	<0.5

Table 4 indicates that all parameters, including kinematic viscosity, density, and an acid number, fulfill biodiesel SNI standards. However, the results of FAME and biodiesel obtained are still low at 41.33% and 42.22%, respectively. The biodiesel yield is strongly influenced by the density and volume of biodiesel produced. In this research, the volume of biodiesel produced is still low so that further research is required to obtain a high yield of FAME and biodiesel.

4 Conclusions

The K₂O/CaO-ZnO catalysts with a variation of mole ratio of CaO:ZnO and %wt K₂O was prepared and tested through the transesterification process to produce biodiesel from soybean oil. The results demonstrated that increasing the mole ratio of CaO to CaO-ZnO catalysts would enhance the catalyst basicity, while the addition of K₂O as a promoter would increase the basicity. The results showed that the basicity of the catalyst increased after the CaO-ZnO catalyst was impregnated with KNO₃ or K₂O in all mole ratios of CaO-ZnO catalyst. The

highest catalyst basicity was obtained in the mole ratio of CaO:ZnO 3:1. The addition of %wt K₂O to the CaO-ZnO catalyst also enhances the catalyst basicity. The addition of K₂O component as a promoter in CaO-ZnO catalyst is necessary because it has a dual function that is to improve the mechanical properties (as a binder) and to increase the catalyst basicity. Testing of 5%K₂O/CaO-ZnO catalyst on biodiesel production showed that the biodiesel fulfills the SNI standard even though the biodiesel yield is still low.

Acknowledgment

The authors thank to the Directorate General of Research and Development, Ministry of Research, Technology, and Higher Education, the Republic of Indonesia for the financial support received under the research project of Hibah Kompetensi Year 2015-2017.

References

1. C.Y. Lin, H.A. Lin, L.B. Hung, *Fuel*, **85**, 1743–1749 (2006).
2. C.Y. Chen, K.L. Yeh, R. Aisyah, D.J. Lee, J.S. Chang, *Bioresour Technol*, **102**, 71–81 (2011)
3. M.L. Granados, M.D.Z. Poves, D.M. Alonso, R. Mariscal, F.C. Galisteo, R. Moreno-Tost, J. Santamaría, J.L.G. Fierro, *Appl Catal B Environ* **73**, 317–326 (2007)
4. M. Kouzu, T. Kasuno, M. Tajika, Y. Sugimoto, S. Yamanaka, J. Hidaka, *Fuel*, **87**, 2798–2806 (2008)
5. S. Gryglewicz, *Bioresour Technol*, **70**, 249–53 (1999)
6. L. Buchori, I. Istadi, P. Purwanto, *Bull Chem React Eng Catal*, **11**, 406–430 (2016)
7. P-L. Boey, G.P. Maniam, S.A. Hamid, *Bioresour Technol*, **100**, 6362–6368 (2009)
8. A.M. Dehkhoda, A.H. West, N. Ellis, *Appl Catal A Gen*, **382**, 197–204 (2010)
9. D.W. Lee, Y.M. Park, K.Y. Lee, *Catal Surv from Asia*, **13**, 63–77 (2009)
10. M. Zabeti, W.M.A. Wan Daud, M.K. Aroua, *Fuel Process Technol*, **90**, 770–777 (2009)
11. A.Z. Fadhel, P. Pollet, C.L. Liotta, C.A. Eckert, *Molecules*, **15**, 8400–8424 (2010)
12. Y.H. Taufiq-Yap, H.V. Lee, M.Z. Hussein, R. Yunus, *Biomass and Bioenergy*, **35**, 827–834 (2011)
13. I. Istadi, U. Mabruro, B.A. Kalimantanini, L. Buchori, D.D. Anggoro, *Bull Chem React Eng Catal*, **11**, 34–39 (2016)
14. S. Semwal, A.K. Arora, R.P. Badoni, D.K. Tuli, *Bioresour Technol*, **102**, 2151–2161 (2011)
15. S.J. Yoo, H. Lee, B. Veriansyah, J. Kim, J-D. Kim, Y-W. Lee, *Bioresour Technol*, **101**, 8686–8689 (2010)
17. C.H. Yulianti, R. Ediaty, D. Hartanto, T.E. Purbaningtyas, Y. Chisaki, A.A. Jalil, C.K.N.L.C.K. Hitam, D. Prasetyoko, *Bull Chem React Eng Catal*, **9**, 100–110 (2014)
17. I. Istadi, S.A. Prasetyo, T.S. Nugroho, *Procedia Environ Sci*, **23**, 394–399 (2015)
18. K. Tanabe, T. Yamaguchi, *J Res Insitute Catal*, **11**, 179–184 (1964)
19. Ž. Kesić, I. Lukić, D. Brkić, J. Rogan, M. Zdujić, H. Liu, D. Skala, *Appl Catal A Gen*, **427–428**, 58–65 (2012)
20. SNI 7182-2015, (2015)